

CORNELL AERONAUTICAL LABORATORY, INC.
BUFFALO, NEW YORK 14221

BICYCLE DYNAMICS
TIRE CHARACTERISTICS AND RIDER MODELING

CAL REPORT NO. YA-3063-K-2
MARCH 1972

Prepared For:
SCHWINN BICYCLE COMPANY
CHICAGO, ILLIONIS 60639

Prepared By:

R. Douglas Roland, Jr.

R. Douglas Roland, Jr.
Assoc. Research Engineer
Vehicle Research Department

Approved By:

K.D. Bird

K.D. Bird, Head
Vehicle Research Department

James P. Lynch

James P. Lynch
Asst. Research Engineer
Computer Center

FOREWORD

The work reported herein was performed in the Vehicle Research Department of Cornell Aeronautical Laboratory, Inc. under Contract No. CC-182 for the Schwinn Bicycle Company. The period of performance was from 5 August 1971 to 29 February 1972. The computer graphics display program was developed by the CAL Computer Center.

TABLE OF CONTENTS

	<u>Page</u>
	iii
1.0	1
2.0	3
2.1	5
2.2	17
3.0	23
3.1	23
3.2	25
4.0	43
4.1	44
4.2	45
4.3	49
5.0	55
5.1	56
5.2	57
5.3	60
5.4	60
5.5	61

		<u>Page</u>
6.0	BIBLIOGRAPHY	65
	Appendix I - Measured and Corrected Tire Data	67
	Appendix II - Full Scale Experimental Test Data	91
	Appendix III - Bicycle Graphics Program Documentation	127
	Appendix IV - Bicycle Graphics Program Listing	161
	Appendix V - Bicycle Graphics Input Data Listing	197

INTRODUCTION AND SUMMARY

In February 1971, Cornell Aeronautical Laboratory, Inc. began a research program, sponsored by Schwinn Bicycle Company. The overall objective of this program was the development of a comprehensive digital computer simulation of a bicycle and rider for studying the effects of certain design parameters on bicycle stability and control. Phase I of this program, completed in June 1971, included the development, validation and exercise of a computer simulation of a free control bicycle. The development of this computer program was supported by the measurement of the physical properties of a bicycle, including the side force characteristics of bicycle tires, and full scale experimental validation tests.

Phase II of this program began in August 1971. The work performed in Phase II included: (1) the development of a closed-loop path-following rider control model and its inclusion in the existing bicycle simulation program, (2) the testing of nine different bicycle tires on the bicycle tire tester which was designed and constructed in Phase I, (3) the performance of full scale experimental tests to determine the effects of certain design variables on bicycle maneuverability and stability, and (4) the development of a computer graphics display program.

The rider control model consists of two related modes of operation: a roll stabilization function and a guidance function. Both of these control functions have been developed for rider steer control. The roll stabilization function has been incorporated in the bicycle simulation and is operational.

An empirical tire side force function has been developed by statistical analysis of the experimental data from nine different bicycle tires. This empirical equation which expresses tire side force as a nonlinear function of vertical force, slip angle and inclination angle is used to represent the tire in the bicycle simulation.

Full scale experimental tests were performed with an instrumented bicycle to determine the effects on stability and maneuverability of the location of luggage load, low tire inflation pressure, and increased front wheel spin moment of inertia.

A computer graphics display program was developed for generating animated movies of a bicycle and rider performing simulated maneuvers. This program when used with the bicycle simulation can produce movies which show the realistic motions of a bicycle and rider including coordinated rider and bicycle steering, pedaling and leaning as well as bicycle chassis translation and rotation.

2.0 RIDER CONTROL MODEL

Phase I included a simulation parameter study of the free-control dynamics of the bicycle. The purpose of this study was to compare the free-control responses of several riderless bicycle configurations to a steering torque disturbance input. The results showed the effects of speed and various design parameter changes on free-control stability. However, it was difficult to conclude from these limited results what effect these changes would have on the stability of a bicycle operated under rider control.

A fundamental objective of this research program is the development of computer simulation of the bicycle which can be used as a design tool. The computer would be used to simulate certain maneuvers in which the resultant motions of the bicycle could be used to determine the effect of specific design parameter changes in the stability and maneuverability of a proposed bicycle.

This approach is similar to the study of automobile dynamics using computer simulation. The general procedure for using the automobile simulation program is to specify a sequence of driver control inputs, simulate the maneuver, and record the motion response of the vehicle. The simulated maneuver is repeated and the responses are compared for several parameter variations of the vehicle but always using the identical driver control inputs. In this manner the dynamics of the automobile may be studied independently of the characteristics of the driver.

This method of using the computer simulation is unsatisfactory for the study of bicycle dynamics. Unlike the automobile, which has inherent roll stability, the bicycle must constantly be balanced by the steering and leaning motions of the rider. Furthermore, complex rider steering and

leaning control are required to accomplish the coordinated rolling and yawing motions of a turning maneuver. The function of the rider in controlling the bicycle is essential to the study of bicycle dynamics. Thus, the investigation of bicycle dynamics requires the inclusion of a closed-loop control model of the rider.

The rider has two basic means of controlling the bicycle - the steer angle of the front wheel and the lean angle of his upper body relative to the frame of the bicycle. By adjusting and changing the steer and lean angles, the rider stabilizes the bicycle and initiates turns. The rider's task of stabilizing the bicycle requires continuous monitoring of the bicycle roll angle and correcting of steer and lean angles. In straight line running and steady state turning, the steering is the primary mode of control. In fact, movies of Phase I experimental tests showed that in "hands-on" steady state cornering the rider did not lean but stayed in plane with the bike. In "hands-off" cornering, however, there was considerable leaning motion. The initiation of turns may be accomplished without leaning motion by steering the "wrong" way first to roll the bicycle into the turn. However, smooth turns can be initiated by leaning in the direction of the turn (without counter-steering first) to roll the bicycle. Full scale tests have shown that both counter-steering and leaning up to angles of approximately twenty degrees were used to perform rapid obstacle avoidance maneuvers.

The use of the simulation for evaluating the stability and maneuverability of various bicycle designs requires two basic functions in the rider control model: (1) roll stabilization - the model must be capable of stabilizing the bicycle in steady cornering as well as straight-line running; (2) guidance - the model must be capable of following a prescribed path by initiating turns and correcting for deviations.

2.1 Roll Stabilization Function of Rider Control Model

The roll stabilization task of the bicycle rider is similar to the manual control task of aircraft pilots. The control system analysis of human operator dynamics has been thoroughly developed and applied to many continuous control tasks. This research has produced mathematical models of the human operators using transfer functions based on experimental data from simulated tracking tasks.

Mathematical modeling of the guidance task of the rider requires special consideration. Since the path following maneuvers to be simulated may have discontinuous inputs (such as avoidance maneuvers), the model must have the capability of viewing the intended path in front of the bicycle. CAL has developed a mathematical model of an automobile driver which has the capability of previewing the intended path, predicting the future path of the vehicle, and determining control inputs based on the error between the predicted and intended path. This model is the basis of the guidance function of the bicycle rider model.

A number of researchers have made mathematical analyses of the free-control stability of two wheel vehicles (see bibliography of Reference 1). However, only Stassen and van Lutenberg, References 2-5, of the Delft University of Technology have undertaken research programs aimed specifically at developing a mathematical model of the stabilizing and controlling function of the bicycle rider. Using a simulator designed to have the same roll dynamics as an actual bicycle, they attempted to determine the human operator transfer functions for the steer and lean control motions. The human operator outputs were steer and lean angles and his inputs were the bicycle roll angle and roll angle derivatives, Figure 2.1.

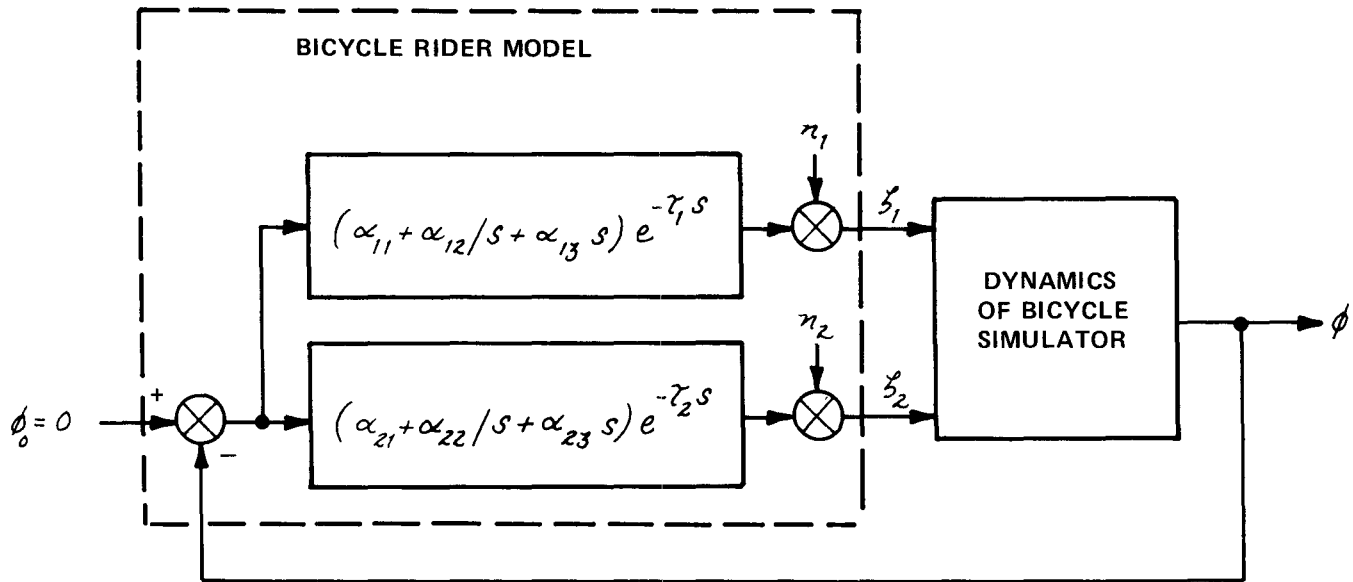

ξ_1 – RIDER OUTPUT STEER ANGLE.

ξ_2 – RIDER OUTPUT LEAN ANGLE.

ϕ – BICYCLE ROLL ANGLE.

ϕ_0 – DESIRED ROLL ANGLE ($\phi_0 = 0$)

$\alpha_{11}, \alpha_{12}, \alpha_{13}$ – PROPORTIONAL, INTEGRAL, AND DERIVATIVE
COEFFICIENTS FOR STEER AND RIDER LEAN
 $\alpha_{21}, \alpha_{22}, \alpha_{23}$ TRANSFER FUNCTIONS

τ_1, τ_2 – DELAY TIMES FOR STEER AND RIDER LEAN.

n_1, n_2 – RIDER REMNANTS

Figure 2.1 BLOCK DIAGRAM OF DELFT UNIVERSITY BICYCLE RIDER MODEL

The rider's transfer function was assumed to take the form

$$H_i(s) = (\alpha_{i1} + \alpha_{i2}/s + \alpha_{i3} \cdot s) e^{-\tau_i s}$$

where s is the Laplace operator. The parameters α_{i1} , α_{i2} , and α_{i3} represent proportional, integral, and derivative coefficients, respectively, and τ_i , the delay time. This human operator transfer function is a simplification of the more general form

$$Y_p(s) = \frac{\kappa_p e^{-\tau s} (\tau_L s + 1)}{(\tau_I s + 1)(\tau_N s + 1)}$$

where κ_p is the gain, τ is the reaction time delay, τ_L and τ_I represent the lead-lag equalization characteristic, and τ_N is the neuro-muscular lag, Reference 6.

Using the bicycle simulator and on-line digital computer for real-time data correlation, the values of the above parameters were determined for several subjects performing a stabilization task. The results showed that the dynamics of the bicycle rider could be described by a model consisting of proportional plus derivative control and a time delay.

The CAL bicycle rider model has human operator characteristics which have been developed in the theory of manual control. However, there are several specific differences between the CAL rider model and the Delft University model and other classical human operator models. The human operator outputs of the CAL model are steering torque and rider lean torque whereas, in the Delft University rider model, the outputs are steer angle and lean angle. The CAL rider model includes the reaction time delay and lag compensation. Moreover, the rider inputs are bicycle roll angle, roll

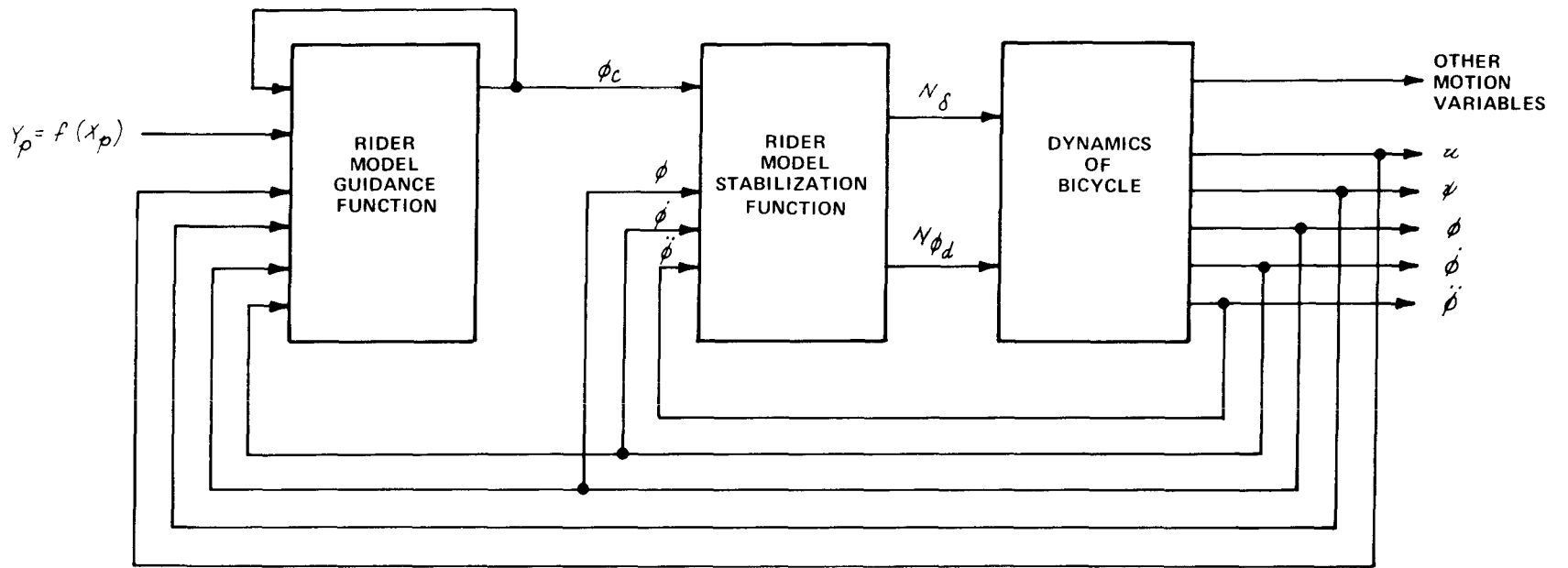

- | | |
|-----------------------------------|----------------------------------|
| u - FORWARD VELOCITY | ϕ_c - COMMAND ROLL ANGLE |
| ψ - YAW ANGLE | N_δ - STEER TORQUE |
| ϕ - ROLL ANGLE | N_{ϕ_d} - RIDER LEAN TORQUE |
| $\dot{\phi}$ - ROLL VELOCITY | |
| $\ddot{\phi}$ - ROLL ACCELERATION | $Y_p = f(x_p)$ - DESIRED PATH |

Figure 2.2 BLOCK DIAGRAM OF BICYCLE-RIDER CONTROL MODEL

velocity, and roll acceleration, and these inputs are sensed directly by visual, kinesthetic, and vestibular sensors. There is a fundamental difference between this representation of the rider and the classical model which assumes that the rider input is the position state of the system output only and that the rider processes this signal to obtain derivative information about the system output.

The CAL rider model, Figure 2.2, assumes that the command input to the stabilization model from the rider guidance model is a desired roll angle (since this is directly related to lateral acceleration). The roll acceleration ($\ddot{\phi}$), the roll velocity ($\dot{\phi}$), and the difference between the command roll angle (ϕ_c) and the actual roll angle (ϕ) have individual coefficients ($C_{\dot{\phi}}$ and C_{ϕ}) relating them to rider steering torque (N_{δ}) and to rider lean torque (N_{ϕ_d}). The reaction time delay and the lag compensation time constant for the steer output (τ_s , $\tau_{\dot{\phi}}$) differ from the delay and lag time constant for lean output (τ_{ϕ} , τ_{ϕ}). Values for all of these parameters are adjustable.

The rider roll stabilization model was programmed for the bicycle computer simulation as shown in Figure 2.3. The rider model was initially exercised in a straight line stability test with only the steer control functioning. The rider was restricted to a zero lean angle. The simulated maneuver was one of stabilizing the bicycle after a side force disturbance. The forward velocity was 10 mph and the side force disturbance was a pulse of 10 pounds for 0.5 seconds. Several simulated maneuvers were made with variations of the rider model coefficients until satisfactory vertical stabilization was obtained. Figure 2.4 shows the resultant bicycle motion with free steering and with rider steering control. With free steering the bicycle immediately fell over; whereas, with rider steering control, the roll motion was damped and the bicycle was returned to a stable vertical running position.

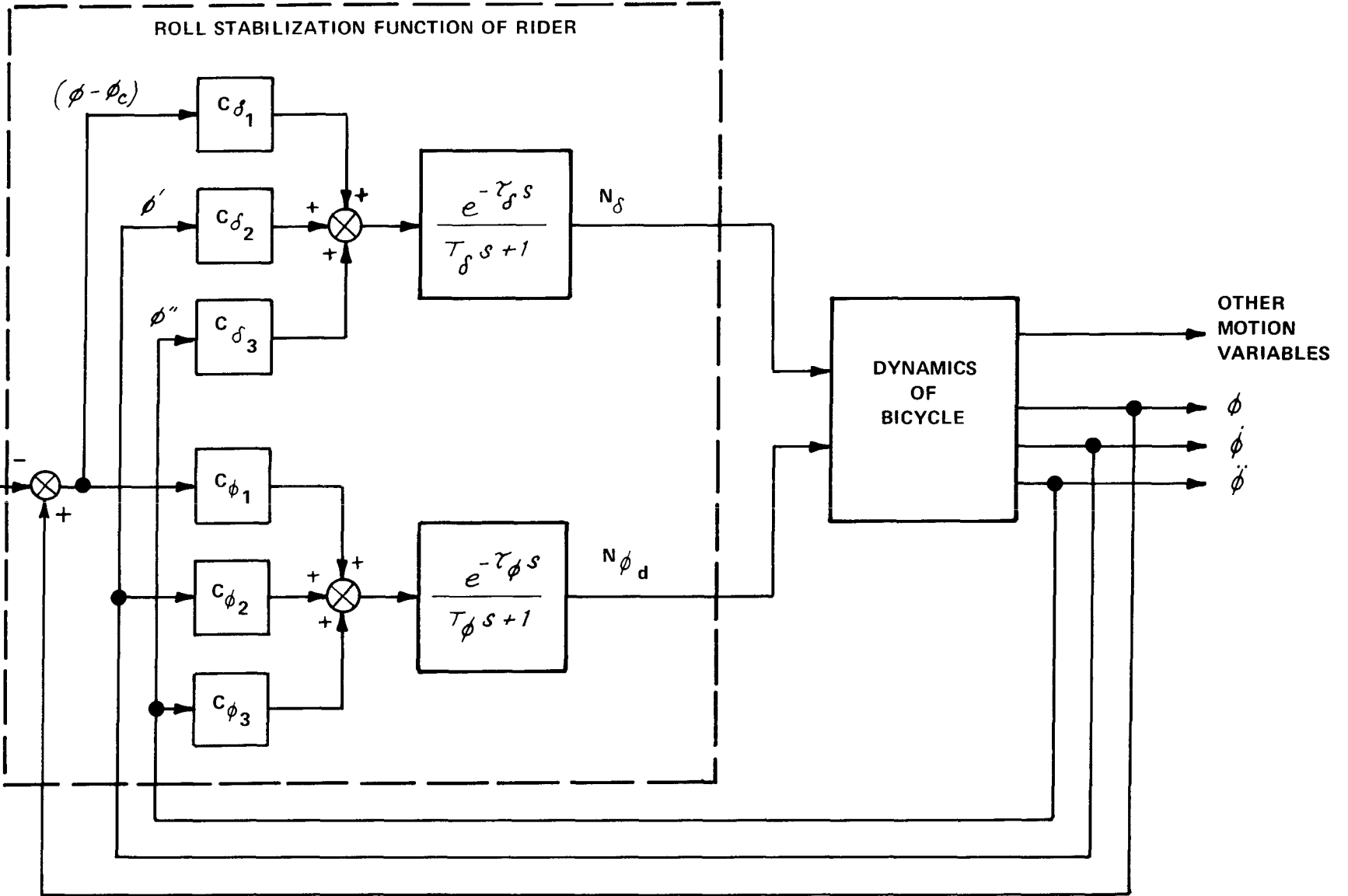

Figure 2.3 BLOCK DIAGRAM OF ROLL STABILIZATION FUNCTION OF BICYCLE RIDER MODEL

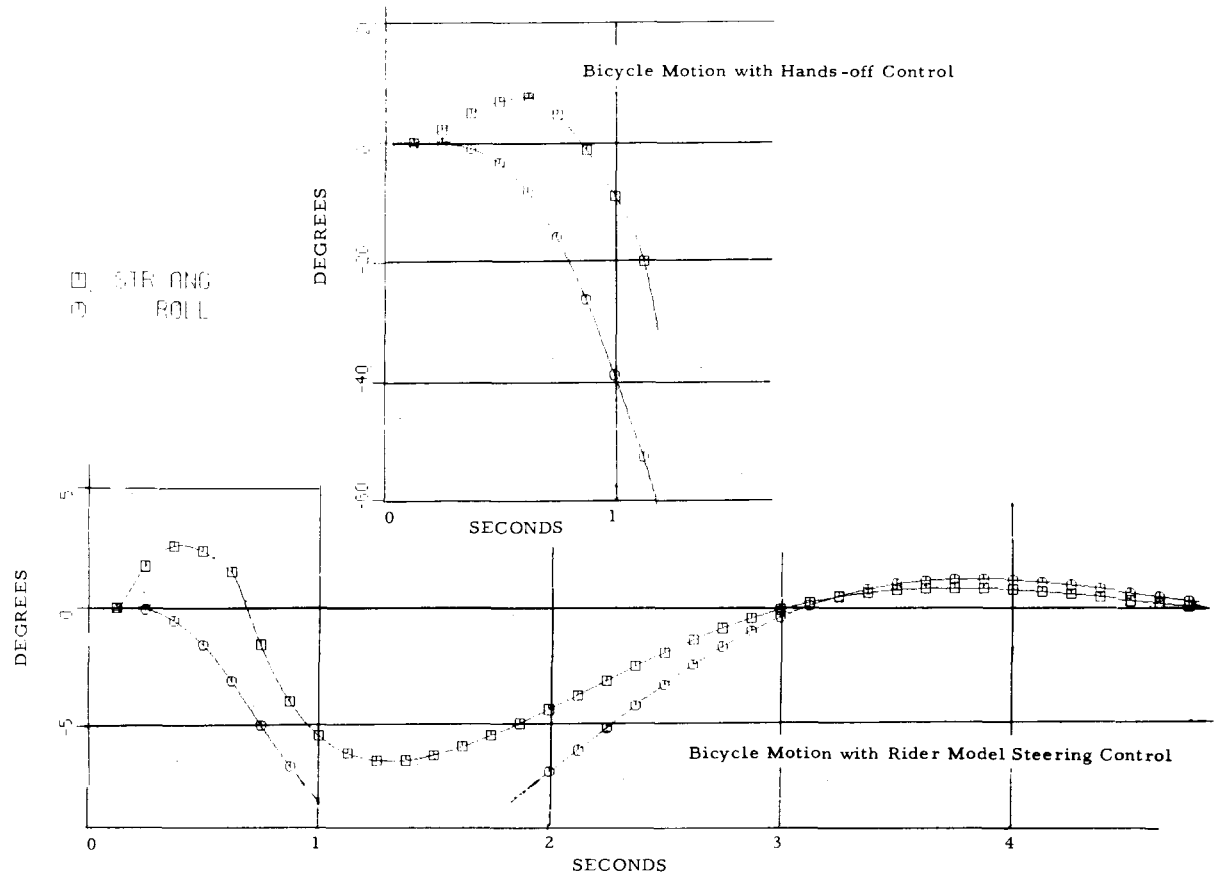

Figure 2.4 SIMULATED MOTIONS OF A BICYCLE AFTER A SIDE FORCE DISTURBANCE

The second test for the rider model was a maneuver in which the bicycle was quickly steered from an initial straight line path to steady state circular path. The bicycle roll angle was 20 degrees for the steady state turn. This maneuver proved to be a rigorous test of the rider model. Several runs were required, varying the rider model coefficients, before satisfactory stabilization was obtained. However, with repeated coefficient variations, excellent performance was achieved. Figure 2.5 shows time histories of the steer angle and rider roll angle for the "best" values of rider coefficients. In this maneuver the bicycle had very quick response (reaching the 20 degree roll angle only 0.6 seconds after the command roll angle reached steady state), good roll damping (very little overshoot), and a steady state roll angle error of only about one degree.

By running many simulation runs with variations in the rider coefficients, it was possible to obtain some understanding of the significance of the different coefficients. It was found that the magnitude of $C_{\delta 3}$ to $C_{\delta 1}$ affected the high frequency (approximately 0.8 Hz) damping of the rider control system. Figures 2.6 shows the effect of increasing $C_{\delta 3}$ from zero to 5 in. -lb. -sec.²/rad. on reducing the oscillatory steer and roll motions. Furthermore, the low frequency damping (less than 0.3 Hz) was influenced by the relative magnitudes of $C_{\delta 2}$ and $C_{\delta 1}$. By increasing the ratio of $C_{\delta 2}$ to $C_{\delta 1}$ from 0.6, Figure 2.7a, to 1.0, Figure 2.7b, a considerable increase in low frequency system damping was obtained. Figure 2.8 shows the effect of a proportional change in all three coefficients. Although the response of the system for both sets of coefficients is well behaved, the steady state error in roll angle was increased by a factor of four by reducing $C_{\delta 1}$, $C_{\delta 2}$, and $C_{\delta 3}$ to one half. This change in coefficients represents an effective reduction in loop gain of fifty percent.

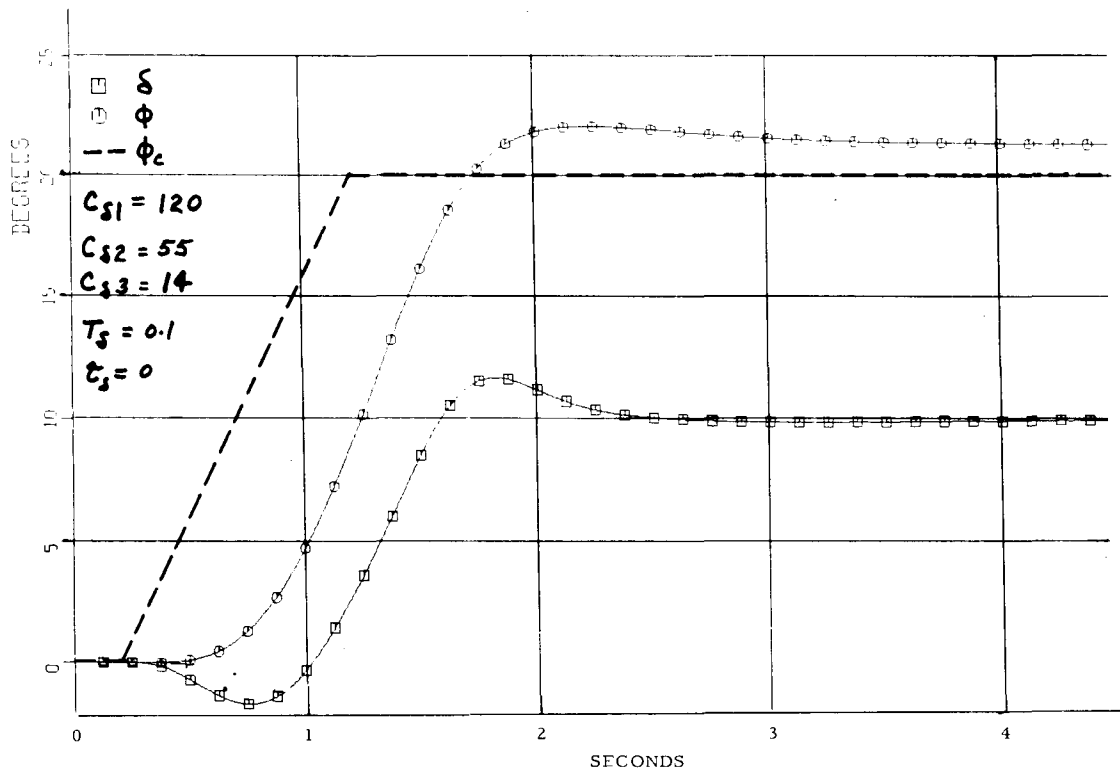

Figure 2.5 BICYCLE RESPONSE TO A 20° COMMAND ROLL ANGLE INPUT WITH "BEST" RIDER MODEL COEFFICIENTS

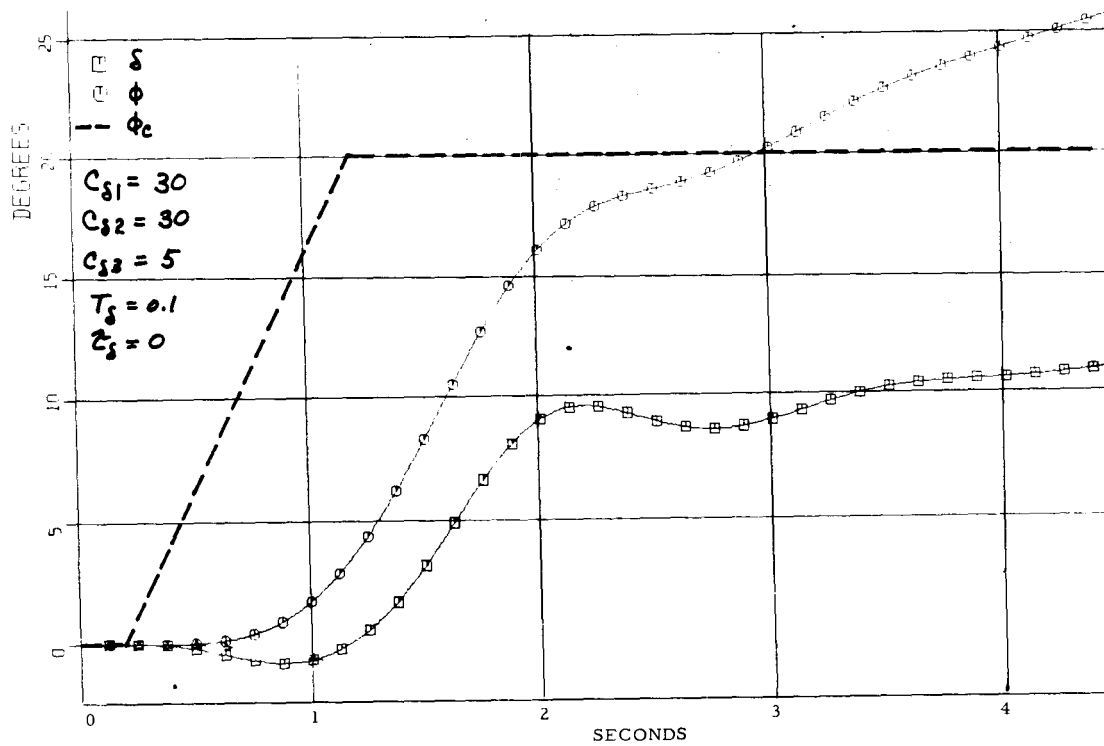
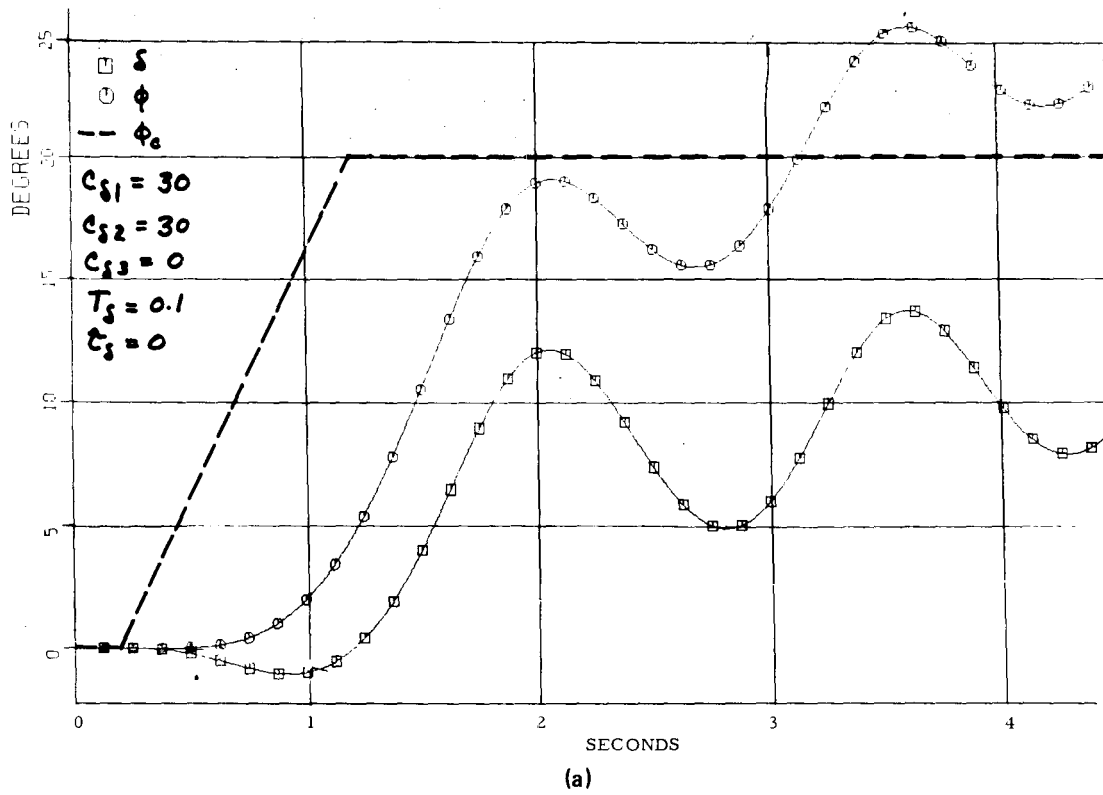

Figure 2.6 THE EFFECT OF $C_{\delta 3}/C_{\delta 1}$ ON HIGH FREQUENCY DAMPING

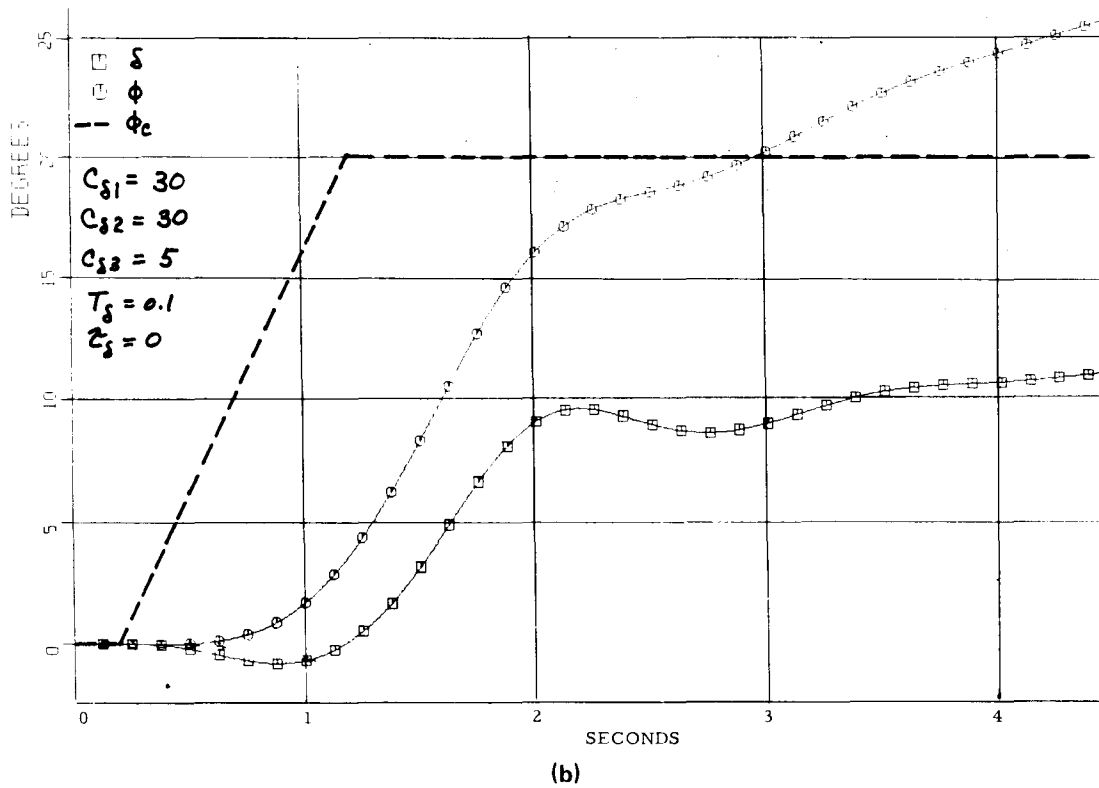
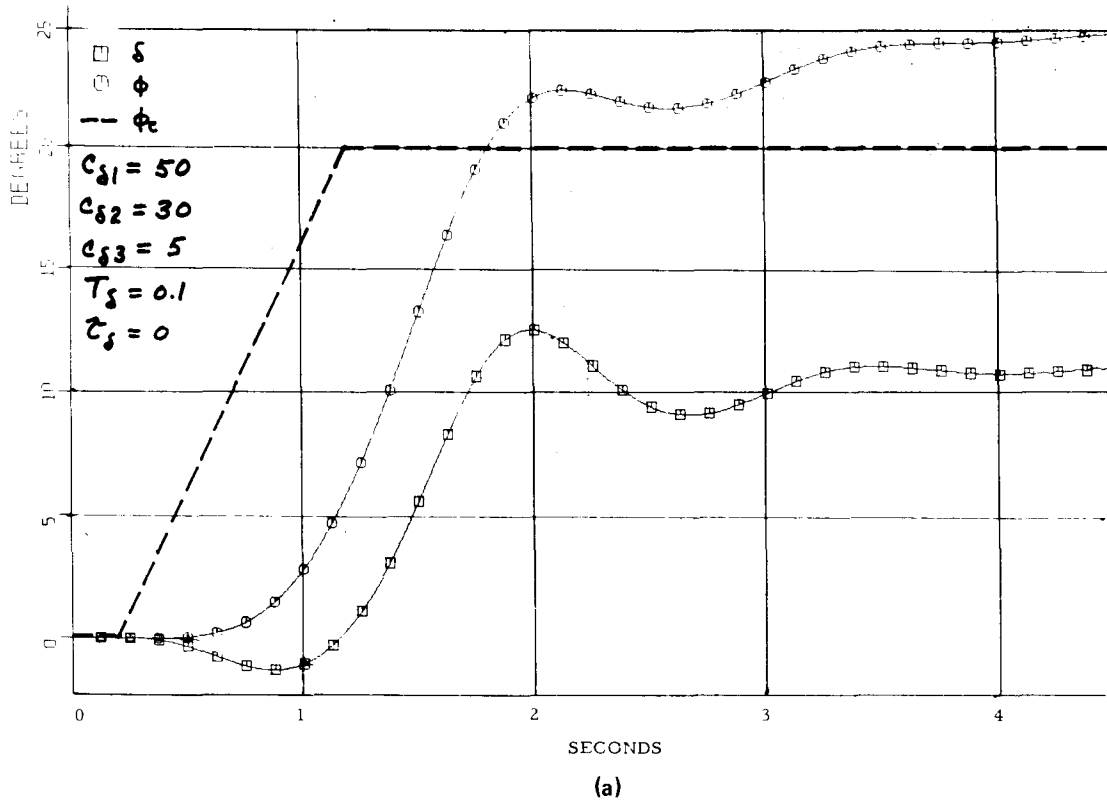
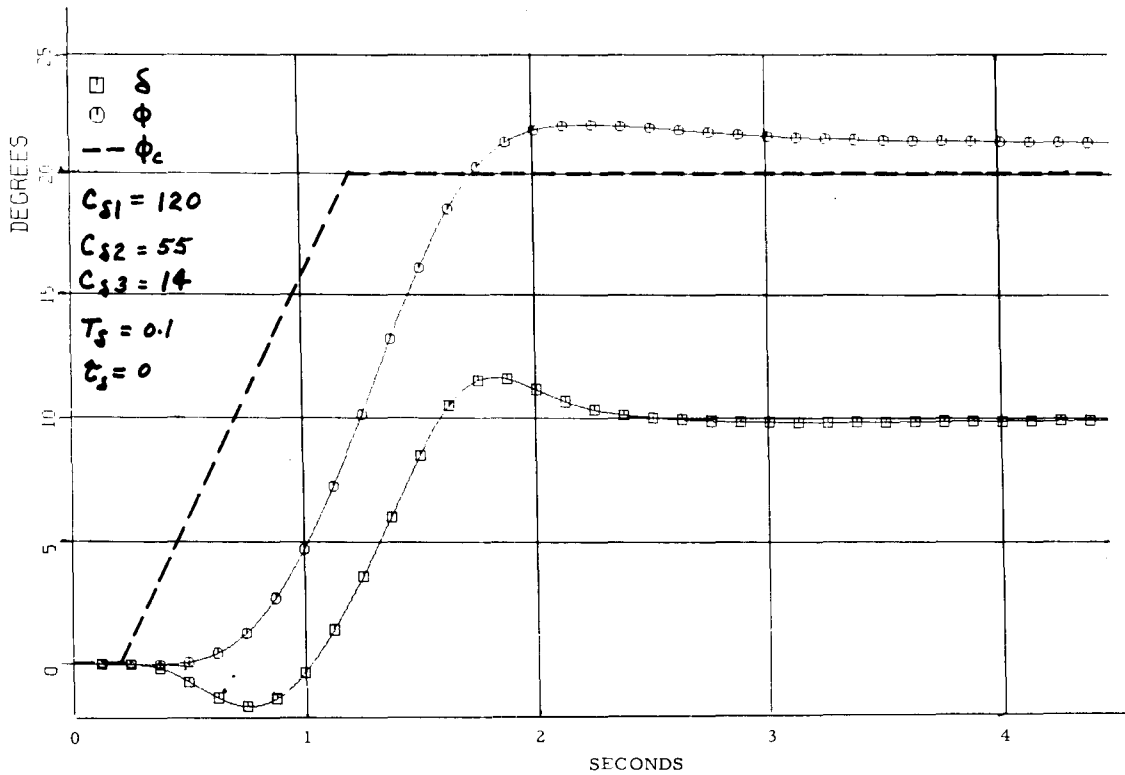
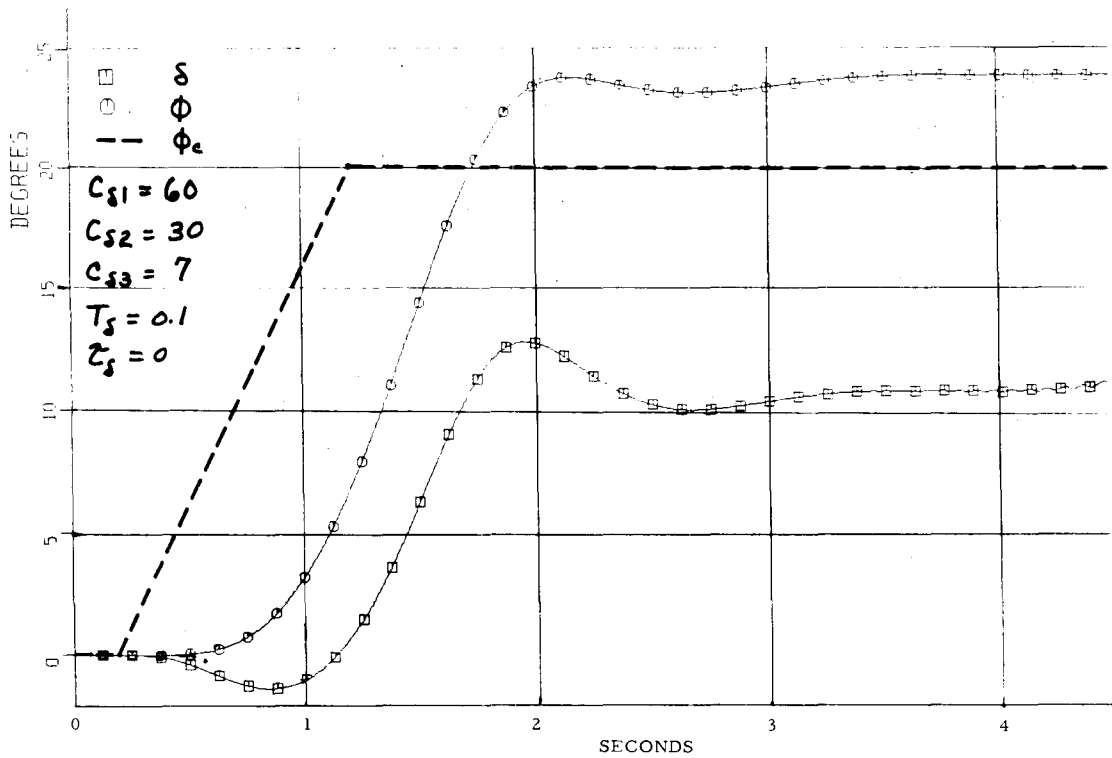

Figure 2.7 THE EFFECT OF $C_{\delta 2}/C_{\delta 1}$ ON LOW FREQUENCY DAMPING



(a)



(b)

Figure 2.8 THE EFFECT OF A CHANGE IN LOOP GAIN ON STEADY STATE ERROR

The third maneuver which was attempted with the rider control model was a simulated slalom run. Although the principal purpose of this maneuver was to produce interesting output for a computer graphics movie (and not to verify the model), the simulated maneuver shows a striking resemblance to the bicycle motion in the full scale experimental tests. Since the path following function of the rider control model was not operational, the following scheme was used to produce a slalom maneuver. The results of the experimental tests showed that the maximum speed at which the wide slalom course (two foot lateral separation between pylons) could be run was approximately nine miles per hour and the maximum roll angle at this speed was about 20 degrees. The initial speed of the simulated maneuver was set to 10 mph and the command roll angle (ϕ_c) was set to 20 degrees. The oscillatory motion was obtained by changing the sign of the command roll angle to oppose the sign of the steer angle. The resultant oscillatory steer and roll motions, Figure 2.9, are similar to the data records of experimental runs in which the rider felt that he "had the timing down."

It was found that the simulated distance traveled between roll angle reversals (10.2 feet), computed from the oscillation period (1.39 seconds) and forward speed (14.67 ft./sec.), is almost identical to the longitudinal distance between pylons in the experimental run (10.0 feet). Most impressive of all is the computer graphics movie of this simulated slalom maneuver in which the pylon spacing was identical to the full scale experimental tests. Computer animation shows the simulated bicycle and rider weaving through the slalom course, narrowly missing the pylons on either side, Figure 5.2.

2.2 Guidance Function of Rider Control Model

The guidance function of the rider control model, Figure 2.2, is based on a "preview-predictor" model of the automobile driver recently

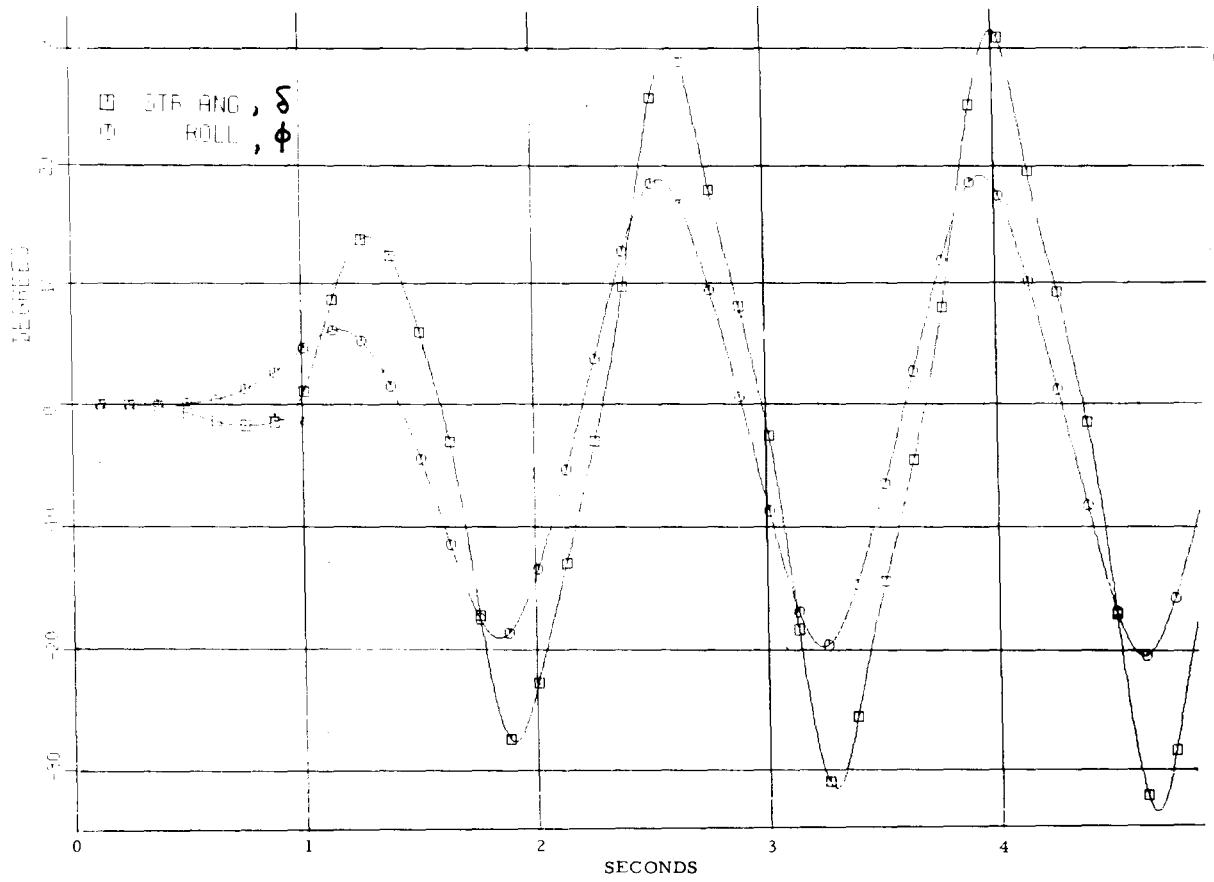

FIGURE 2.9 BICYCLE MOTIONS FOR A SIMULATED SLALOM MANEUVER

developed by CAL, Reference 7. This model was formulated on the theory that the driver has the ability to predict the future course of his vehicle and compare it with the previewed desired path. Control commands are based on the error between the desired and predicted paths, Figure 2.10.

In predicting the future path of the bicycle, the forward velocity (u) is assumed to remain equal to the current velocity. The lateral acceleration is assumed equal to the acceleration due to gravity (g) times the tangent of the bicycle roll angle. The predicted future roll angle (ϕ_p) is determined by integration of the current roll velocity ($\dot{\phi}$) into the future time (t_p), with the current roll angle (ϕ) as the initial condition.

$$\phi_p = \dot{\phi} t_p + \phi$$

Therefore, the predicted lateral acceleration (a_{yp}) varies with future time.

$$a_{yp} = g \tan \phi_p$$

$$a_{yp} = g \tan (\dot{\phi} t_p + \phi)$$

The coordinates of the predicted path (x'_{pp} , y'_{pp}) in the space fixed coordinate system are calculated by integration of the respective components of the velocity and of the predicted lateral acceleration using the current bicycle position (x'_0 , y'_0) as an initial condition.

$$x'_{pp} = x'_0 + t_p u \cos \psi - 1/2 t_p^2 a_{yp} \sin \psi$$

$$y'_{pp} = y'_0 + t_p u \sin \psi + 1/2 t_p^2 a_{yp} \cos \psi$$

ψ is the current yaw angle of the bicycle with respect to the x' axis of the space fixed coordinate system.

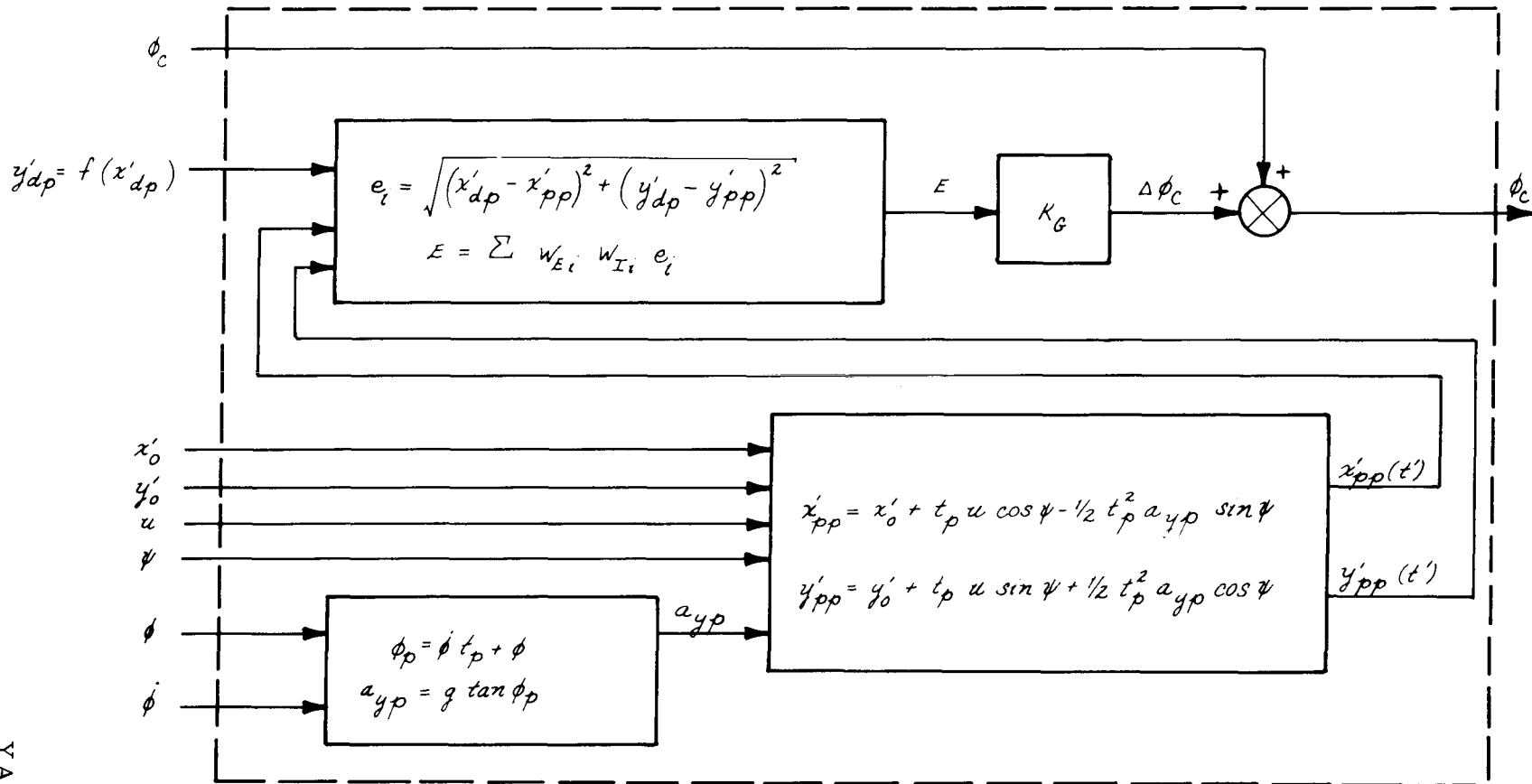

Figure 2.10 BLOCK DIAGRAM OF GUIDANCE FUNCTION OF BICYCLE RIDER MODEL

The desired path, $y'_{dp} = f(x'_{dp})$, is defined by a series of circular arcs (or straight line segments) which connect points whose coordinates are specified as input. The circular arcs are mathematically defined to produce tangency at the junctions.

The error (e_i) between the predicted path and the desired path is measured at several intervals of time into the future. The measured errors are weighted to account for the reduction in lateral acceleration required to correct errors at further distances ahead of the vehicle (w_{Ei}) and to emphasize the importance of errors at particular locations along the desired path (w_{Ii}). From the cumulative weighted error (E) a correction to command roll angle ($\Delta\phi_c$) is computed which acts to bring the predicted path closer to the desired path. Therefore, by repetitive future path predictions, error computations, command roll angle corrections, and the resultant control exercised by the stabilization function of the rider model, the bicycle-rider model attempts to follow the desired path.

3.0 BICYCLE TIRE TESTING

Phase I of this program included the design and construction of an on-road bicycle tire tester. The tire tester was designed to be towed behind an automobile and to have the capability of measuring the lateral force characteristics of all bicycle tire sizes in current production. Tire side force is measured as a function of normal load, slip angle, and inclination angle which are variable within ranges of 35 to 150 pounds, -3 to +10 degrees, and -6 to +45 degrees, respectively. A complete description of the bicycle tire tester is given in Reference 1.

3.1 Tire Tester Calibration

A thorough recalibration of the tire tester was performed when the test rig was installed on the tow car for the Phase II testing. Two types of data correction information were required:

- (1) correction of the strain gage bridge output for sensitivity changes which occur with changes in inclination angle and normal load
- (2) correction of the steer and inclination angles for compliance of the test structure under the tire side force and normal load.

Laboratory calibration was performed by applying known side forces of zero to 70 pounds in 10 pound increments and reading the output of the strain gage bridge, the compliance steer angle, and the compliance inclination angle. This calibration was repeated for all combinations of 0, 50, and 100 pound normal loads; 0, 20, and 40 degree inclination angles; and 0 and 6 degree steer angles. The resultant data were processed by a

statistical computer program to determine the correlation between gage bridge output and the side force, normal load, inclination angle, and steer angle. A functional relationship between these variables was initially hypothesized as -

$$R = C_1 F + C_2 I + C_3 I^2 + C_4 L + C_5 L^2 + C_6 S$$

where: R is the strain gage bridge output
 F is the side force
 I is the inclination angle
 L is the normal load
 S is the steer angle

The correlation coefficient of strain gage output with side force along ^z was found to be greater than 0.9996, showing the excellent linearity of the instrument.

By including inclination angle to the first power and load to the second power, the correlation coefficient was improved to 0.9998. The other variables included in this statistical analysis proved to be insignificant. Thus, the analysis yielded the following functional relationship -

$$R = 31.46 F - 0.0911 I + 0.00371 L^2$$

Therefore, the actual side force can be determined from the strain gage bridge output and the inclination angle and normal load configuration of the test by the following equation.

$$F = (R + 0.0911 I - 0.00371 L^2) / 31.46$$

The steer compliance was found to be -0.0399 degrees of steer per pound of side force and the compliance inclination was found to be 0.0236 degrees of inclination per pound of side force. These coefficients were found to be relatively independent of other variables.

One additional correction was made to the data to account for a steer angle bias in the measured data and is due to the practical problems of aligning the tire in the test rig at exactly zero steer angle. This bias angle is computed from the corrected data by determining, by interpolation, the steer angle at which the side force is zero. Thus, the corrected steer and inclination angles may be computed from measured data by the following expressions.

$$S = S_m - 0.0399F - S_b$$

$$I = I_m - 0.0236F$$

where: S is the corrected steer angle
 S_m is the measured steer angle
 S_b is the steer angle bias
 I is the corrected inclination angle
 I_m is the measured inclination angle
 F is the side force

3.2 Statistical Analysis and Modeling of Tire Data

Phase I included the measurement of side force characteristics of two bicycle tires, a 27 x 1-1/4 Breeze Sports Touring and a 27 x 1-1/4 Puff High Pressure Road Racer (manufactured by National). The first of these is a conventional tire with a rated inflation pressure of 65 psi and

the second is a gum rubber side wall tire with a rated inflation pressure of 75 psi. Although the test data were not statistically analyzed, plots of the reduced data showed fundamental differences in the side force characteristics of the two tires.

In order to extend the knowledge of side force characteristics to a wider range of bicycle tire types, nine additional tires were tested in Phase II. The data from these tests were analyzed statistically to formulate a nonlinear empirical expression relating side force to normal load, slip angle, and inclination angle.

The tires tested in Phase II, Table 3.1, were representative of a wide range of production tires -- gum sidewall types, a square cross section slick, similar tires made by different manufacturers, a sew-up road racing tire, a experimental radial ply, as well as conventional tires. Rim diameters ranged from 24 to 27 inches and rated inflation pressures ranged from 55 to 110 psi.

The procedure for using the tire tester was well developed in Phase I and is explained in the Phase I technical report. The Phase II test matrix included three normal loads (37.2 , 70.3 , 104.5), eleven steer angles (-3, -2, -1, 0, 1, 2, 3, 4, 6, 8, 10 degrees), and five inclination angles (0, 10, 20, 30, 40 degrees). Each tire was tested for the complete matrix of load, steer, and inclination configurations except for steer angles above which slippage first occurred. Approximately 160 individual measurements were made for each tire (including repeat measurements). Appendix 1 contains tabulated values of the measured and corrected data.

Table 3.1
COEFFICIENTS OF NORMALIZED SIDE FORCE FUNCTION FOR VARIOUS TIRES

TIRE TYPE	CORR. COEF.	STD. ERROR	C_1	C_2	C_3	C_4	C_L
FASTBACK SLIK 24 x 1-3/8 (60 psi)	0.982	0.080	-0.264×10^{-2}	0.239	-0.225×10^{-2}	0.018×10^{-2}	0.329
BREEZE SPORTS TOURING 24 x 1/4 (60 psi)	0.991	0.056	-0.236×10^{-2}	0.216	-0.205×10^{-2}	0.205×10^{-2}	0.287
STRAIGHT SIDE SPORTS TOURING 24 x 1-3/8 (60 psi)	0.981	0.079	-0.063×10^{-2}	0.195	-0.173×10^{-2}	0.247×10^{-2}	0.066
STRAIGHT SIDE SPORTS TOURING 26 x 1-3/8 (60 psi)	0.989	0.066	-0.252×10^{-2}	0.261	-0.233×10^{-2}	0.212×10^{-2}	0.310
PUFF ROAD RACER-CARLISLE 27 x 1-1/4 (75 psi)	0.984	0.072	-0.213×10^{-2}	0.213	-0.233×10^{-2}	0.212×10^{-2}	0.254
HP SPORTS TOURING 27 x 1-1/4 (85 psi)	0.982	0.077	-0.235×10^{-2}	0.233	-0.242×10^{-2}	0.193×10^{-2}	0.286
BREEZE SPORTS TOURING 27 x 1-1/4 (65 psi)	0.971	0.083	-0.119×10^{-2}	0.223	-0.272×10^{-2}	0.482×10^{-2}	0.131
PUFF ROAD RACER-NATIONAL 27 x 1-1/4 (75 psi)	0.967	0.075	-0.210×10^{-2}	0.249	-0.569×10^{-2}	0.437×10^{-2}	0.250
CLEMENT #50 ROAD TIRE 27 SEW-UP (110 psi)	0.989	0.060	-0.153×10^{-2}	0.209	-0.191×10^{-2}	0.172×10^{-2}	0.173
PUFF ROAD RACER RADIAL 27 x 1-1/4 (75 psi)	0.967	0.096	-0.268×10^{-2}	0.150	-0.135×10^{-2}	0.764×10^{-2}	0.336
LETOUR 27 x 1-1/4 (85 psi)	0.947	0.151	-0.350×10^{-2}	0.263	-0.314×10^{-2}	1.054×10^{-2}	0.475

NORMALIZED SIDE FORCE FUNCTION: $F/L = (1 + C_1 L) (C_2 S + C_3 S^3 + C_4 I)$

In order to describe the tire side force characteristics more accurately for the bicycle simulation program, a statistical analysis was made of the corrected data for all tires to determine an empirical polynomial function. The following expression was initially hypothesized -

$$F/L = (1 + C_1 L) (C_2 S + C_3 S^2 + C_4 S^3 + C_5 S I + C_6 S^2 I + C_7 S I^2 + C_8 I + C_9 I^2 + C_{10} I^3)$$

where: F is the side force
 L is the normal load
 S is the slip angle
 I is the inclination angle
 C_n are the constants which represent the particular tire

A statistical data analysis computer program was used to determine the constants of the above expression which gave the best correlation with the corrected tire data. Since this statistical analysis program gave correlation coefficients and standard errors of each term of the expression with the corrected data, it was possible to eliminate the terms which had low correlation with side force and those in which there was little confidence in the numerical results. The following resultant empirical function was obtained by the above method.

$$F/L = (1 + C_1 L) (C_2 S + C_3 S^3 + C_4 I + C_5 I^3)$$

The correlation coefficients of the above expression with the actual corrected data range from 0.947 to 0.991. Standard errors range from 0.056 to 0.151. Table 3.1 gives the polynomial coefficients, correlation coefficients, and standard errors for each tire.

In general, tires become less effective as the vertical force on them increases. The side force does not increase in proportion to an increase in vertical load (i. e., the normalized side force (F/L) decreases with increasing vertical load, all other variables remaining constant). Bicycle tires are no exception as shown by the bicycle tire data. Thus, the empirical side force function contains the term $(1 + C_7 L)$ term to account for this effect. Note that C_7 is always negative.

Figure 3.1 shows the normalized side force function for the 24 inch Fastback Slik plotted for three vertical loads. Since all plots for a particular tire have the same characteristic shape, it is redundant to plot the function for more than one load. However, the change in normalized side force with vertical load varies from tire to tire. Thus, it is important to know the magnitude of this load effect as well as the characteristic shape of the function.

A load sensitivity coefficient (C_L) has been defined as the percentage change in normalized side force per pound increase in vertical load. The load sensitivity coefficient can be derived from the normalized side force function.

$$C_L = \frac{\alpha(F/L)/\alpha L}{F/L} \times 100\%$$

$$C_L = \frac{C_7(C_2 S + C_3 S^3 + C_4 I)}{(1 + C_7 L)(C_2 S + C_3 S^3 + C_4 I)} \times 100\%$$

$$C_L = \frac{C_7}{1 + C_7 L} \times 100\%$$

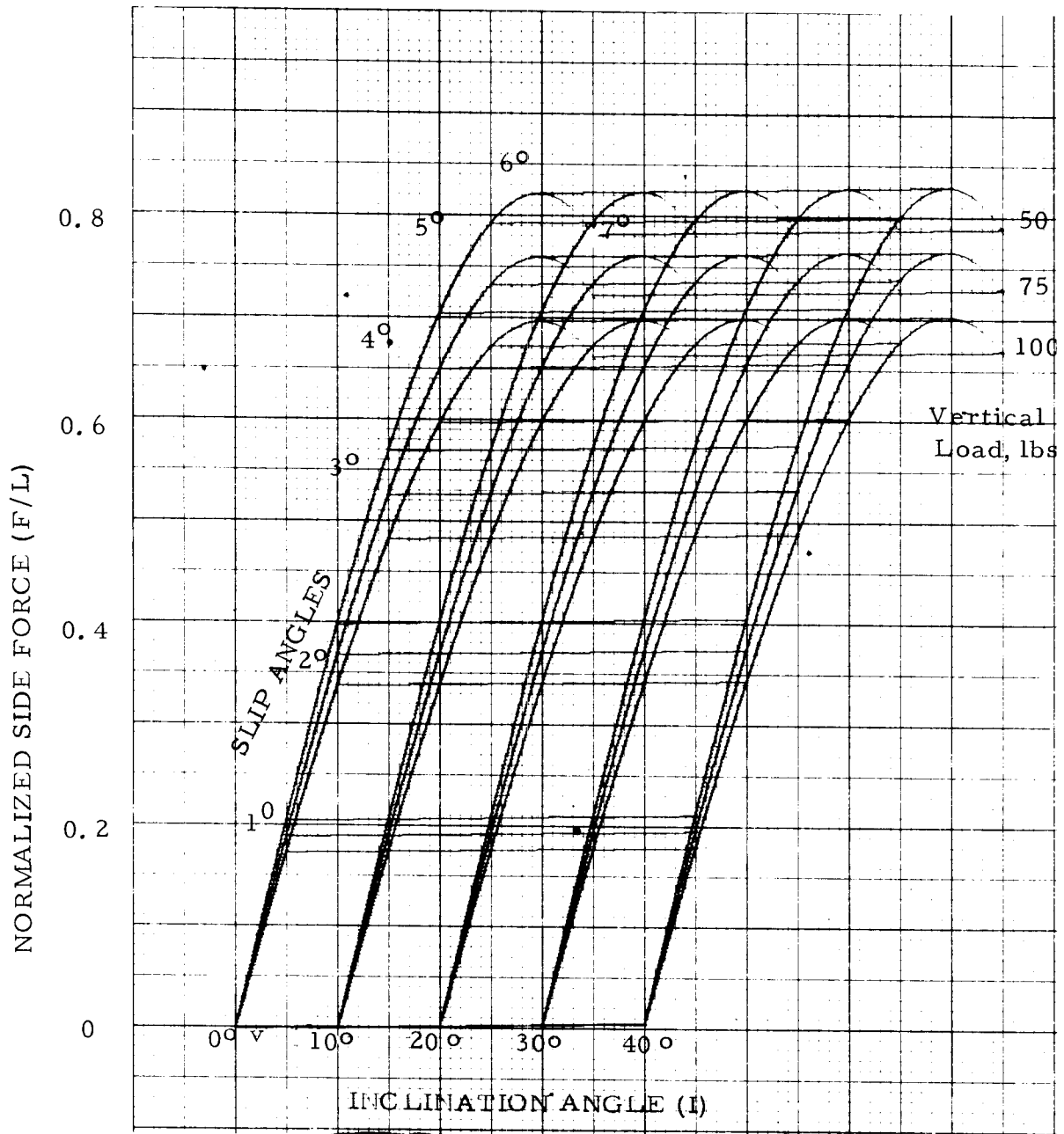

Figure 3.1 NORMALIZED SIDE FORCE FUNCTION FOR THREE VERTICAL LOADS

Since this coefficient varies with vertical load, a standard load was established for computing C_L and for plotting the normalized side force function. Seventy-five pounds was chosen for the standard load since this load is representative of the mean front and rear load for a 30-pound bicycle with a 120 pound rider. Load sensitivity coefficients for all the tires tested are given in Table 3.1.

Figures 3.2 through 3.12 are plots of the normalized side force functions of the different tires at the standard vertical load of 75 pounds.

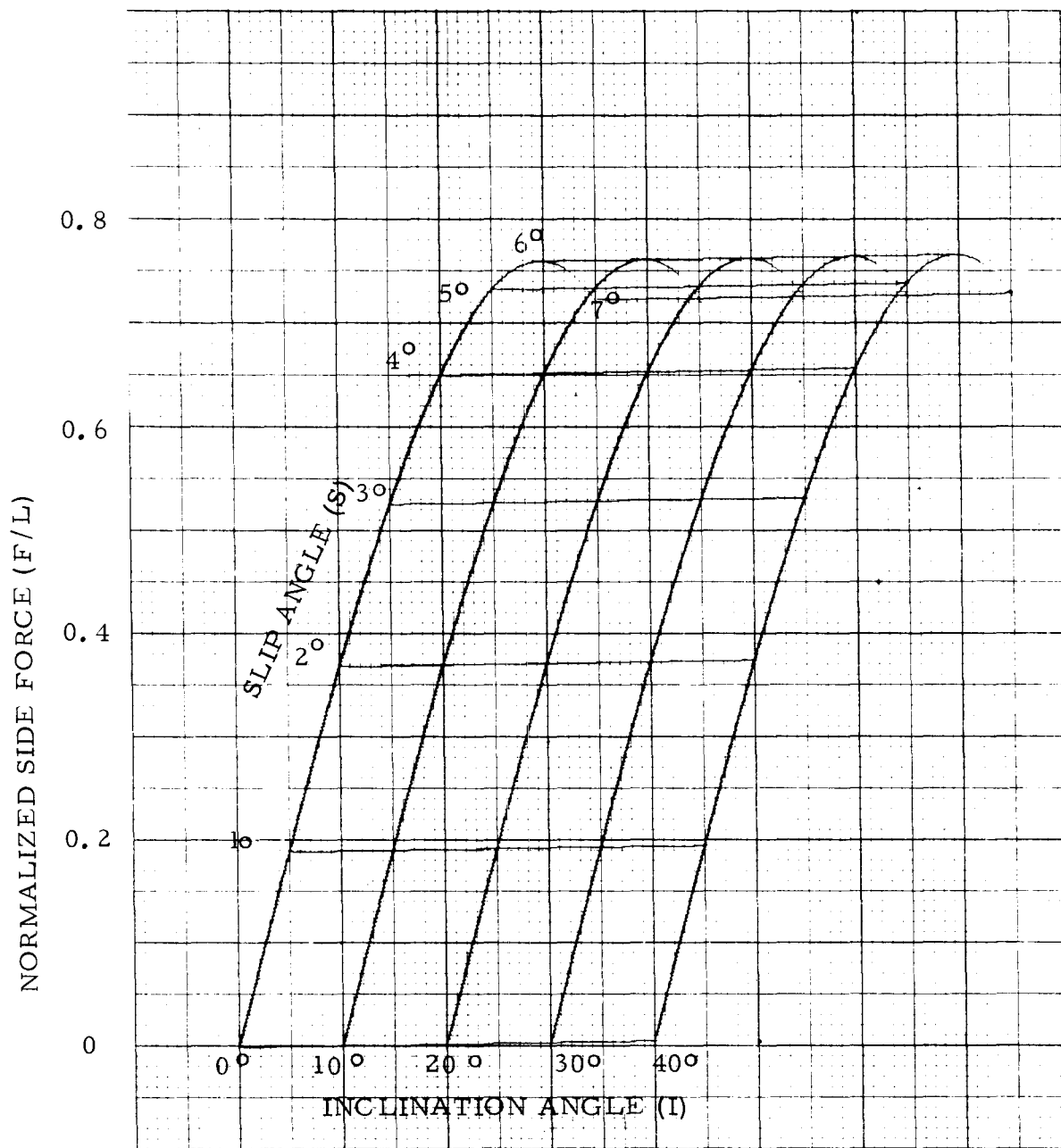

Figure 3.2 NORMALIZED SIDE FORCE FUNCTION, 24- 1-3/8 FASTBACK SLIK

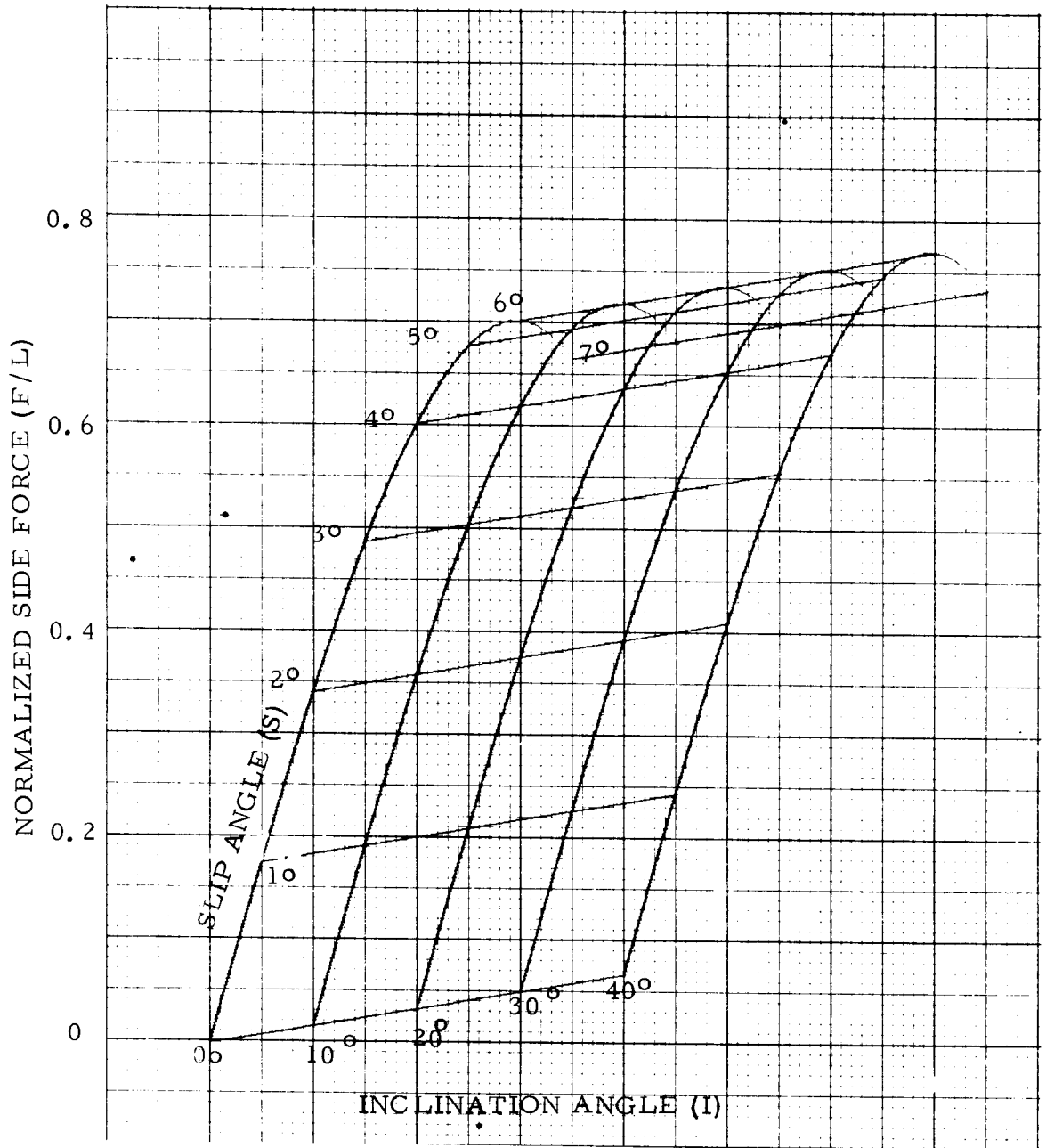

Figure 3.3 NORMALIZED SIDE FORCE FUNCTION, 24- 1-1/4 BREEZE SPORTS TOURING

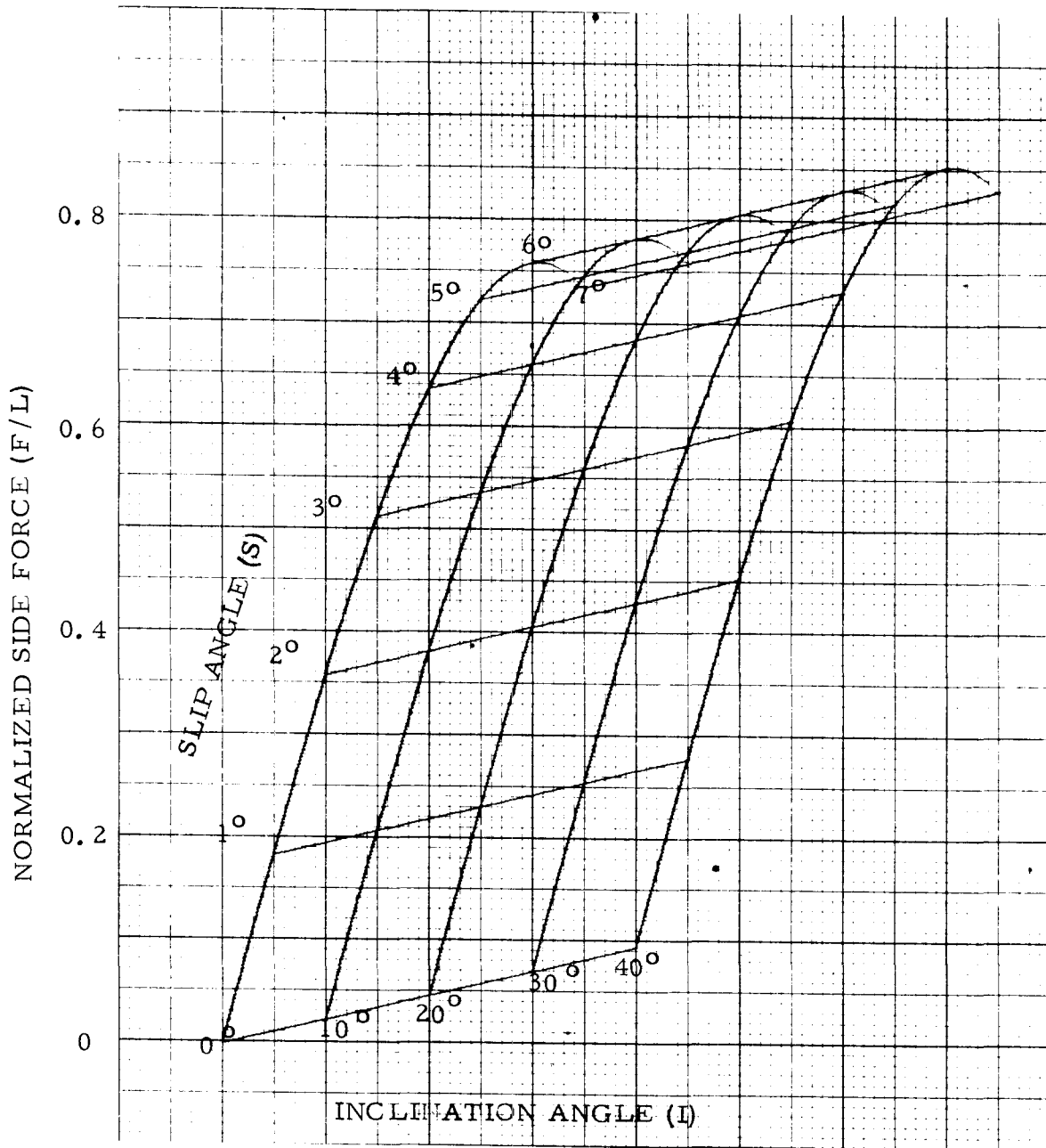

Figure 3.4 NORMALIZED SIDE FORCE FUNCTION, 24 - 1-3/8 STRAIGHT SIDE SPORTS TOURING

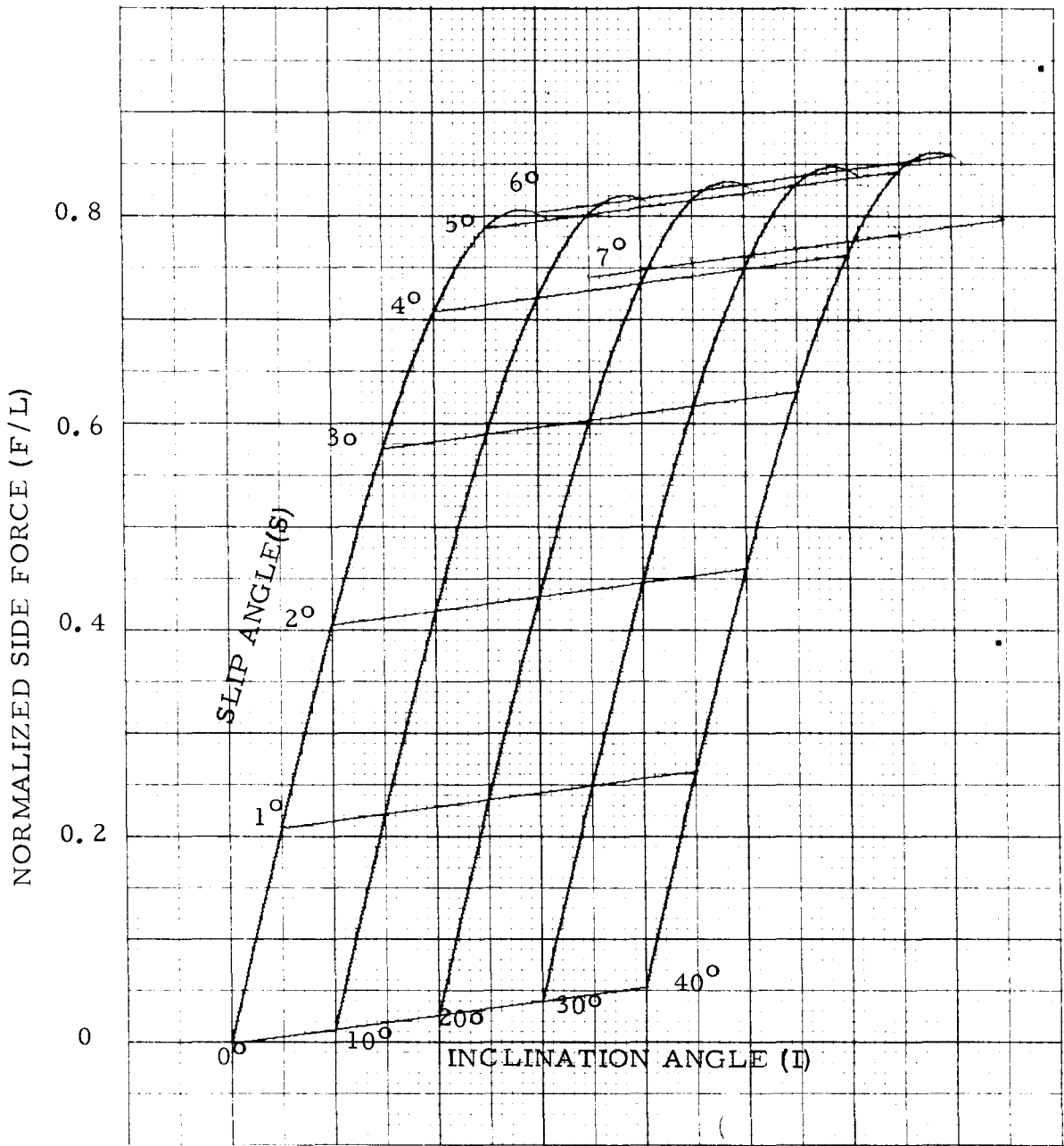

Figure 3.5 NORMALIZED SIDE FORCE FUNCTION, 26 - 1-3/8 STRAIGHT SIDE SPORTS TOURING

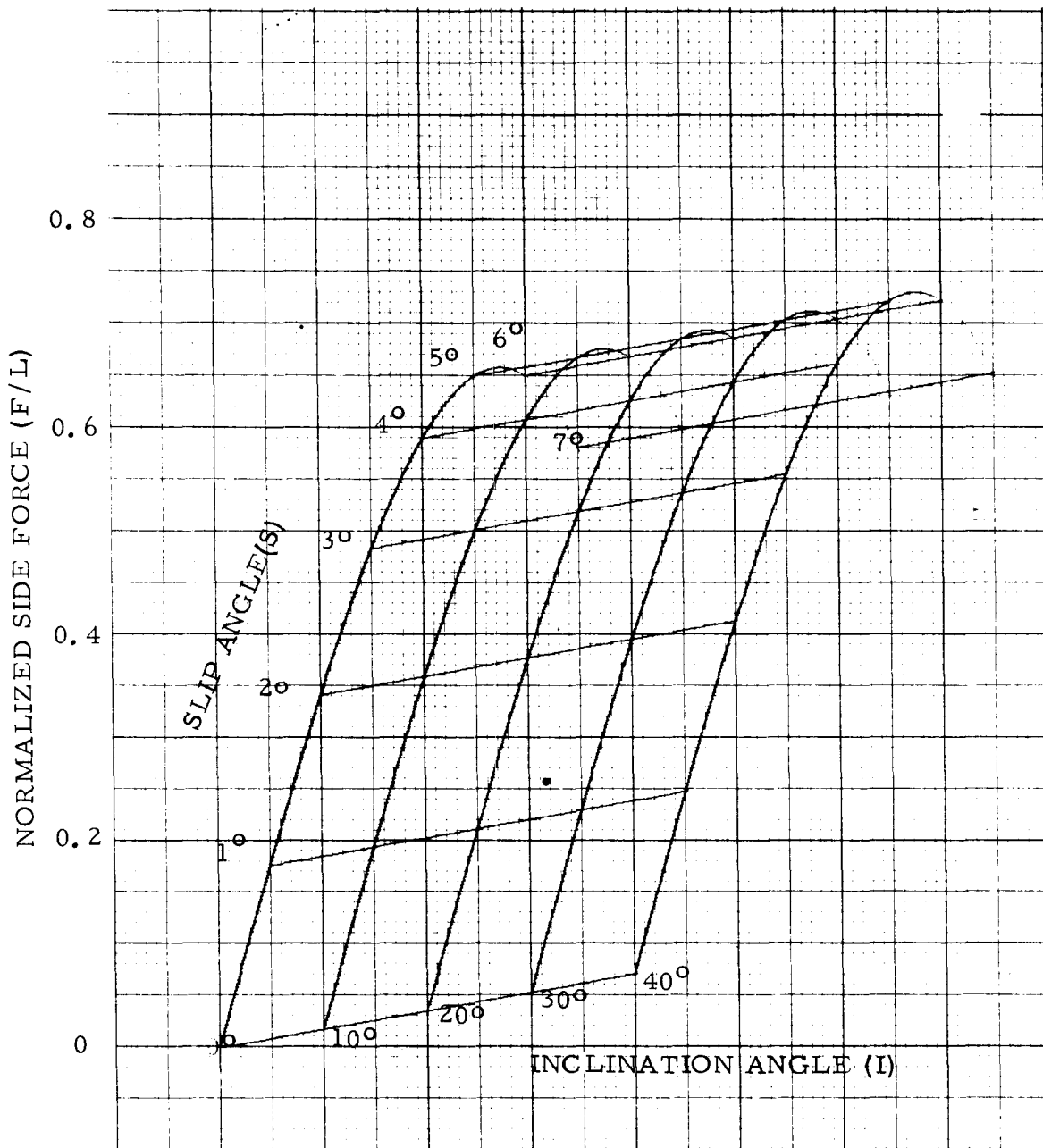

Figure 3.6 NORMALIZED SIDE FORCE FUNCTION, 27 - 1-1/4 PUFF ROAD RACER - CARLISLE

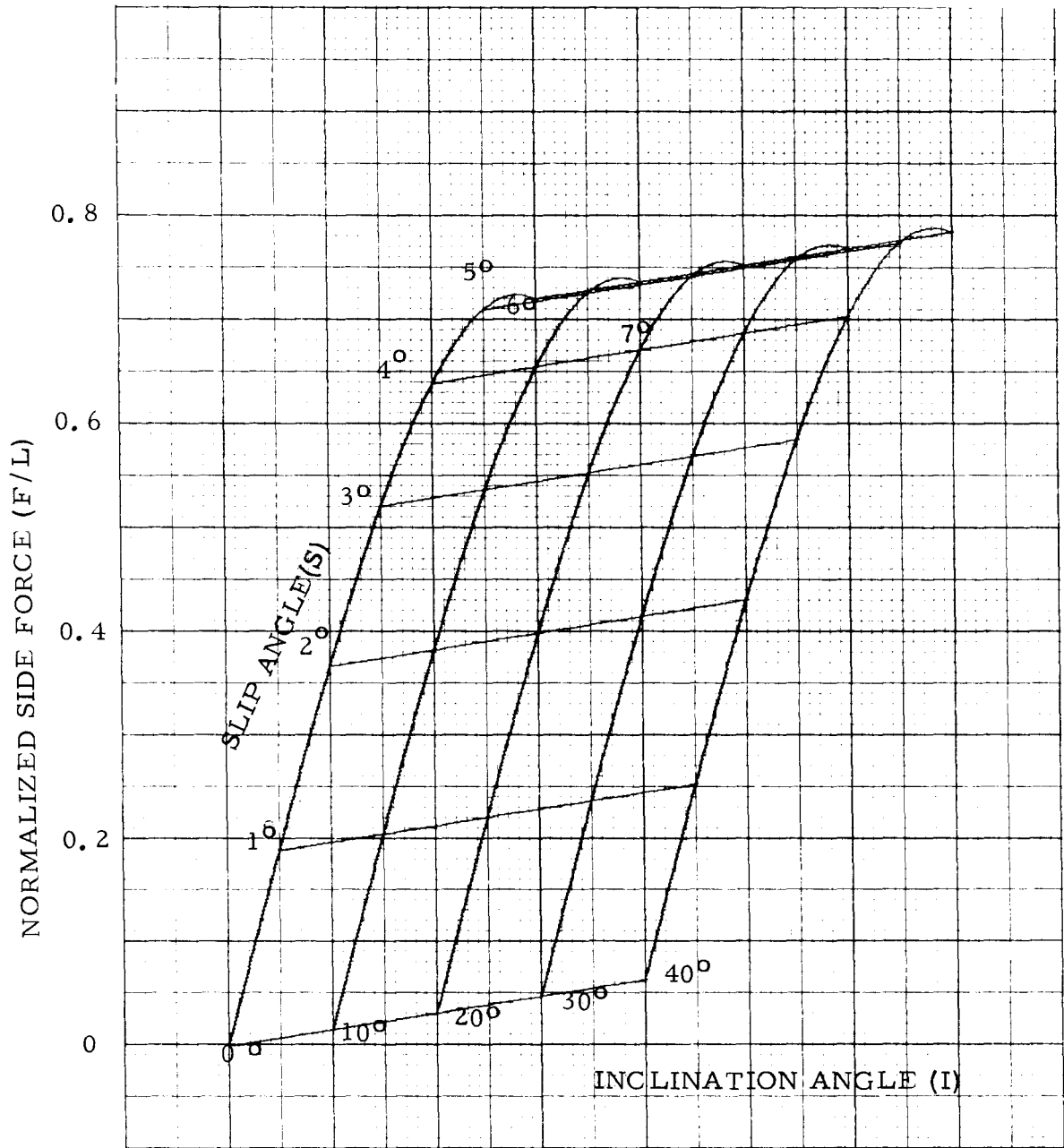

Figure 3.7 NORMALIZED SIDE FORCE FUNCTION, 27 - 1-1/4 HP SPORTS TOURING

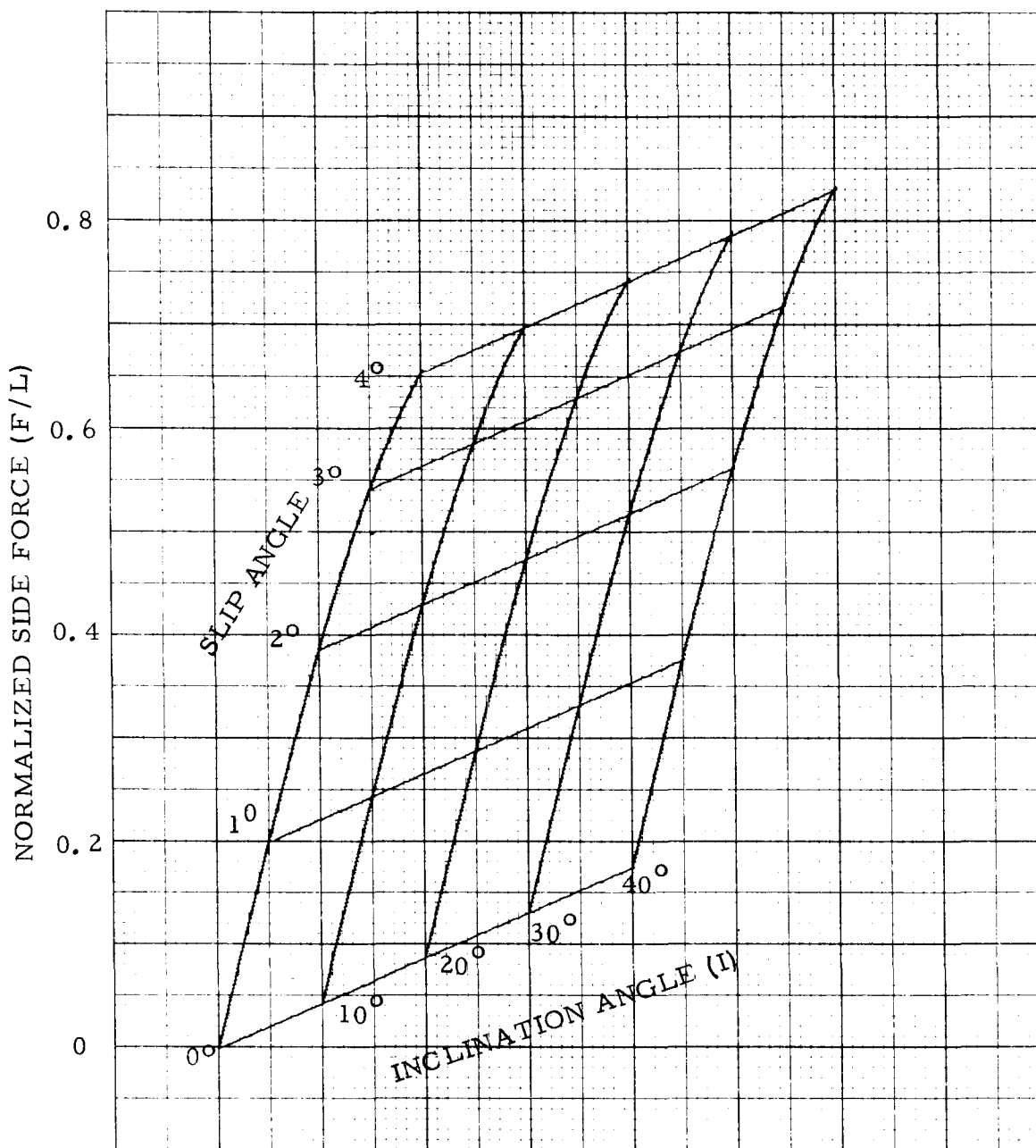

Figure 3.8 NORMALIZED SIDE FORCE FUNCTION, 27 - 1-1/4 BREEZE SPORTS TOURING

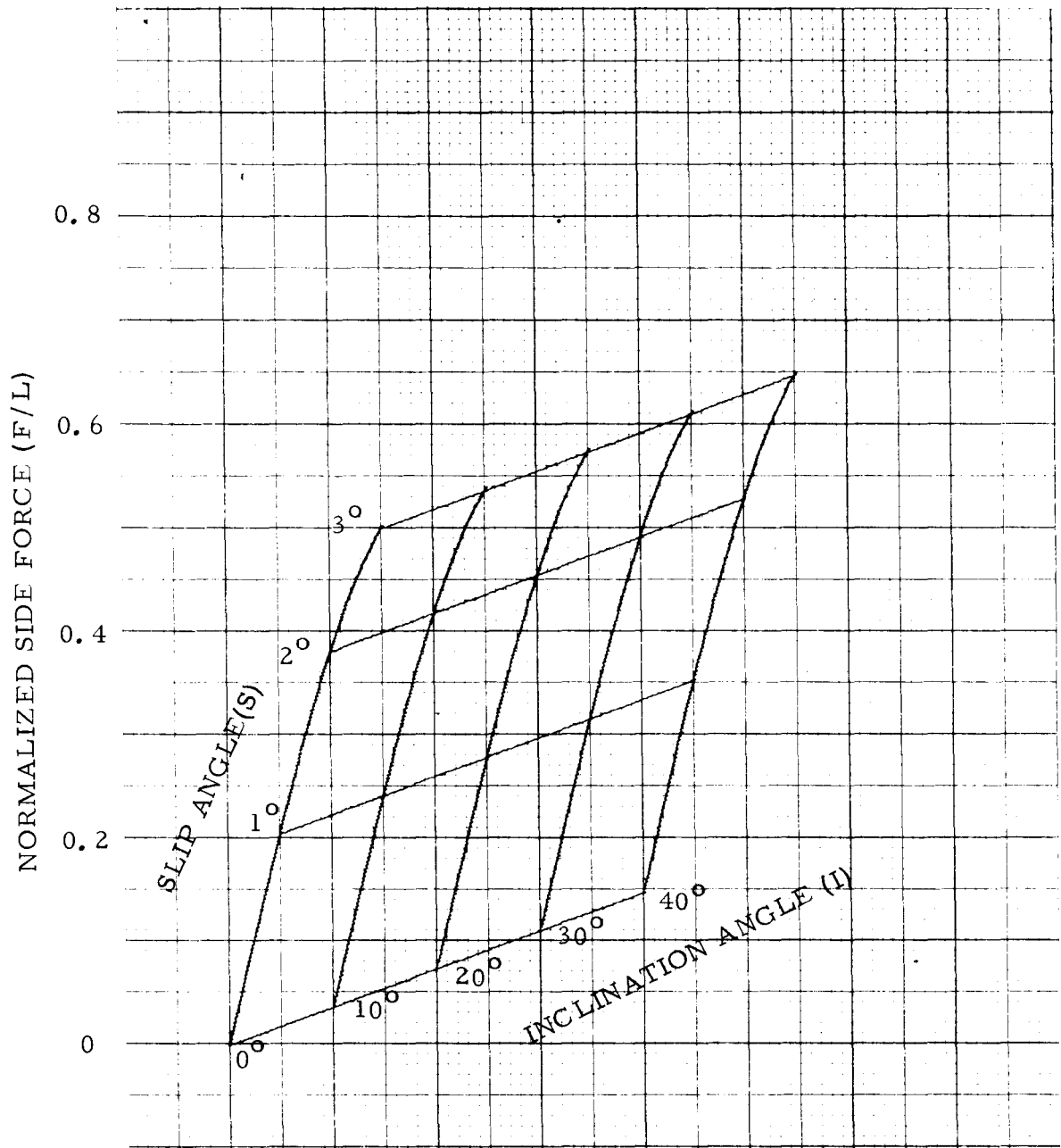

Figure 3.9 NORMALIZED SIDE FORCE FUNCTION, 27 - 1-1/4 PUFF ROAD RACER - NATIONAL

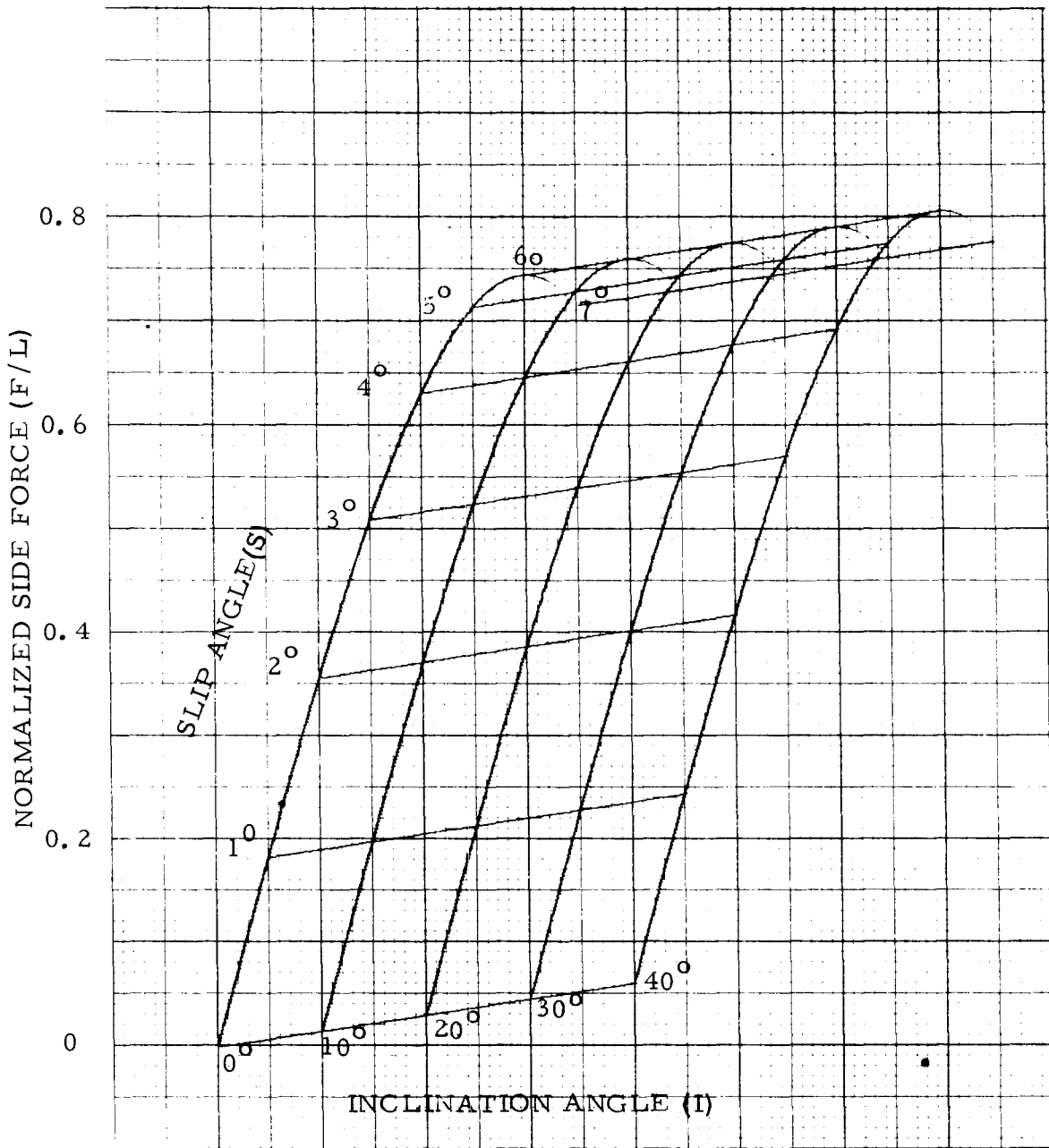

Figure 3.10 NORMALIZED SIDE FORCE FUNCTION, 27 - SEW-UP CLEMENT #50 ROAD TIRE

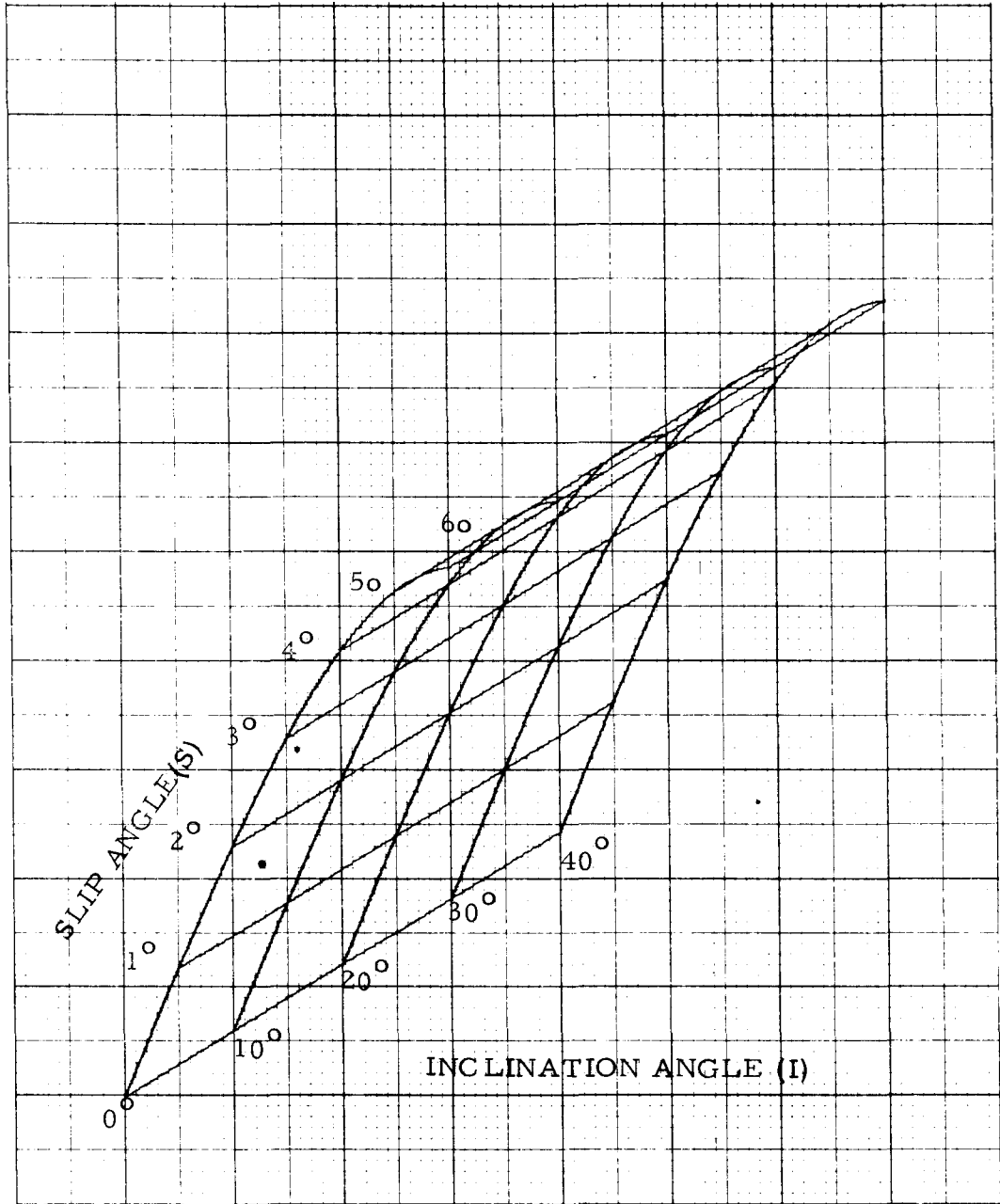

Figure 3.11 NORMALIZED SIDE FORCE FUNCTION, 27 X 1-1/4 PUFF ROAD RACER RADIAL

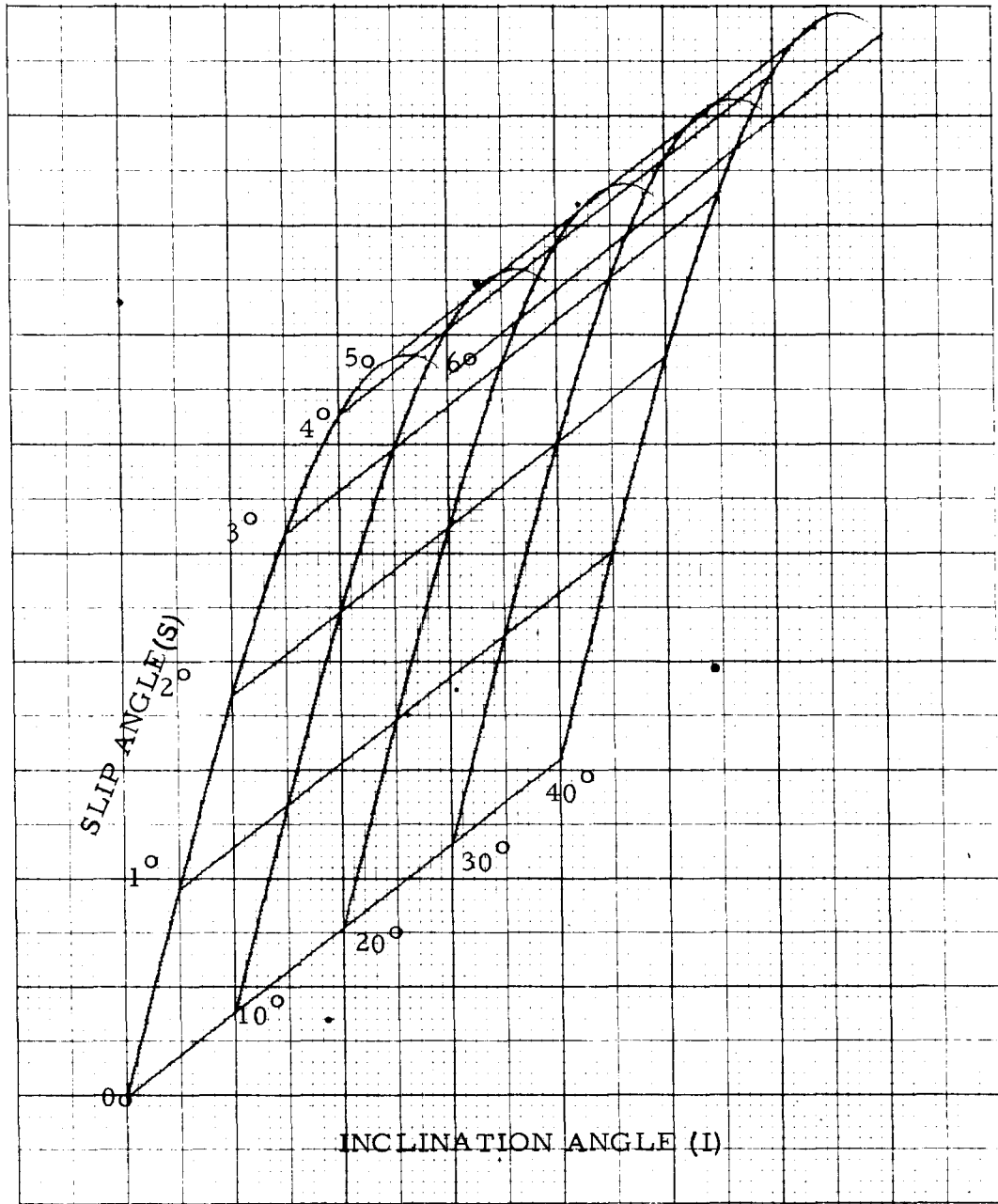

Figure 3.12 NORMALIZED SIDE FORCE FUNCTION, 27 X 1-1/4 LETOUR

4.0 EXPERIMENTAL TESTING OF BICYCLE

Actual cycling experience during the experimental bicycle tests of Phase I and the preliminary simulation parameter study indicated significant effects of certain bicycle parameters on its stability and handling. Among these parameters are the spin moment of inertia of the front wheel, the addition of a luggage load at different locations on the bicycle and the under-inflation of the front or rear tire. A full scale experimental program was conducted in Phase II to study the effects of these parameters. An important aspect of this testing was the accumulation of experimental data to be used for the formulation and validation of the rider control model. These data included time histories of roll angle, steer angle, lateral acceleration and velocity for all maneuvers.

The test bicycle was instrumented with a potentiometer for measuring front wheel steer angle, a gyroscope for measuring bicycle roll angle, and accelerometer for measuring lateral acceleration, and a tach-generator for measuring forward velocity. These data were recorded on two 2-channel strip chart recorders which were carried with the power supplies in a chase car. Instrumentation power and data signals were transmitted to and from the bicycle through a light weight cable loosely hung from a boom extending from the chase car. Reference 1 contains a detailed discussion of the test bicycle instrumentation. 16 mm. movie coverage was made of all experimental tests. The camera was remotely controlled by strip switches laid on the pavement at the beginning and end of the test course.

4.1 Maneuvers

Four basic maneuvers were performed in the experimental testing. These maneuvers were selected to emphasize low speed stability and normal speed stability and maneuverability.

Low Speed Stability - The purpose of this test was to measure the low speed stability of the various bicycle configurations. A one foot wide lane was set up with small pylons separated approximately three feet along both sides of the 100 foot long lane. The measure of stability was the minimum speed at which the bicycle could be stably ridden through the entire lane without hitting any pylons.

Obstacle Avoidance - The purpose of this test was to measure the maneuverability of the nine bicycle configurations. The same one foot wide lane which was used in the low speed stability test was used in this test. A two foot wide - three foot high obstacle (plastic garbage can) was placed on the centerline of the lane four feet beyond the last pair of pylons. The rider's task was to ride through the lane at constant speed and then turn sharply (either right or left) to avoid the obstacle. The performance measure is the maximum speed at which the maneuver can be performed without hitting either the pylons or the obstacle.

Narrow Slalom Course - The purpose of this maneuver is to measure the controllability of the different bicycle configurations at normal riding speeds. An eleven pylon slalom course was set up with all pylons in a straight line and ten feet apart. The bicycle was ridden through the slalom course at increasing speeds until the maximum speed for that particular configuration was determined. Approximately five runs were made with each bicycle configuration.

Wide Slalom Course - This maneuver is the same as the narrow slalom course with the exception that there is a two foot lateral separation between successive pylons. The measure of performance is the speed at which the slalom course can be run without hitting any pylons.

4.2 Bicycle Configurations

Each of the four test maneuvers was performed with nine different bicycle configurations. Five of these bicycle configurations were designed to study the effects of luggage load location on bicycle stability and handling. Two configurations were to determine the effects of low front and rear tire pressures. One configuration was designed to study the effect on stability of increasing the spin moment of inertia of the front wheel. The other bicycle configuration was the standard bicycle.

A. Standard Bicycle - A special single-speed Schwinn suburban bicycle with coaster brakes. This standard configuration included instrumentation, front luggage rack, rear luggage rack and left and right rear wire baskets, Figure 4.1. The tires were Puff Road Racers inflated to the rated pressure of 75 psi. The weight of the bicycle, instrumentation, luggage carriers, and wire baskets was approximately 51 pounds.



Figure 4.1 STANDARD BICYCLE WITH 12½ POUND LOAD ON BOTH FRONT AND REAR CARRIERS

B. High Wheel Spin Inertia - Standard bicycle with the front wheel spin moment of inertia increased from 1.76 lb-in-sec² to 3.00 lb-in-sec². The moment of inertia was increased by taping 3.24 pounds of wire solder to the inside of the wheel rim at a distance of 12.13 inches from the spin axis, Figure 4.2.

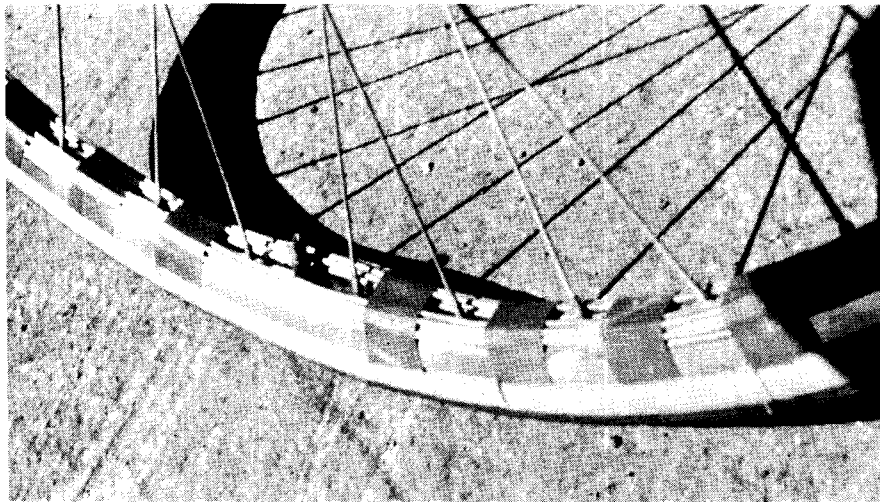

Figure 4.2 HIGH SPIN MOMENT OF INERTIA WHEEL

C. Low Front Tire Pressure - Standard bicycle with the front tire pressure reduced from 75 psi to 20 psi. At this pressure the tire was conspicuously under-inflated.

D. Low Rear Tire Pressure - Standard bicycle with the rear tire pressure reduced from 75 psi to 35 psi. At 35 psi the more highly loaded rear tire had the same amount of flattening as the front at 20 psi.

E. Load on Rear Carrier - Standard bicycle with a 25 pound load rigidly mounted on the rear luggage carrier. The load was a hollow wooden block filled with lead shot. The block was approximately 4 inches wide, 6 inches high and 12 inches long. The c.g. of the load for this configuration was in the plane of the bicycle approximately 19 inches above and 1 inch behind the rear wheel center.

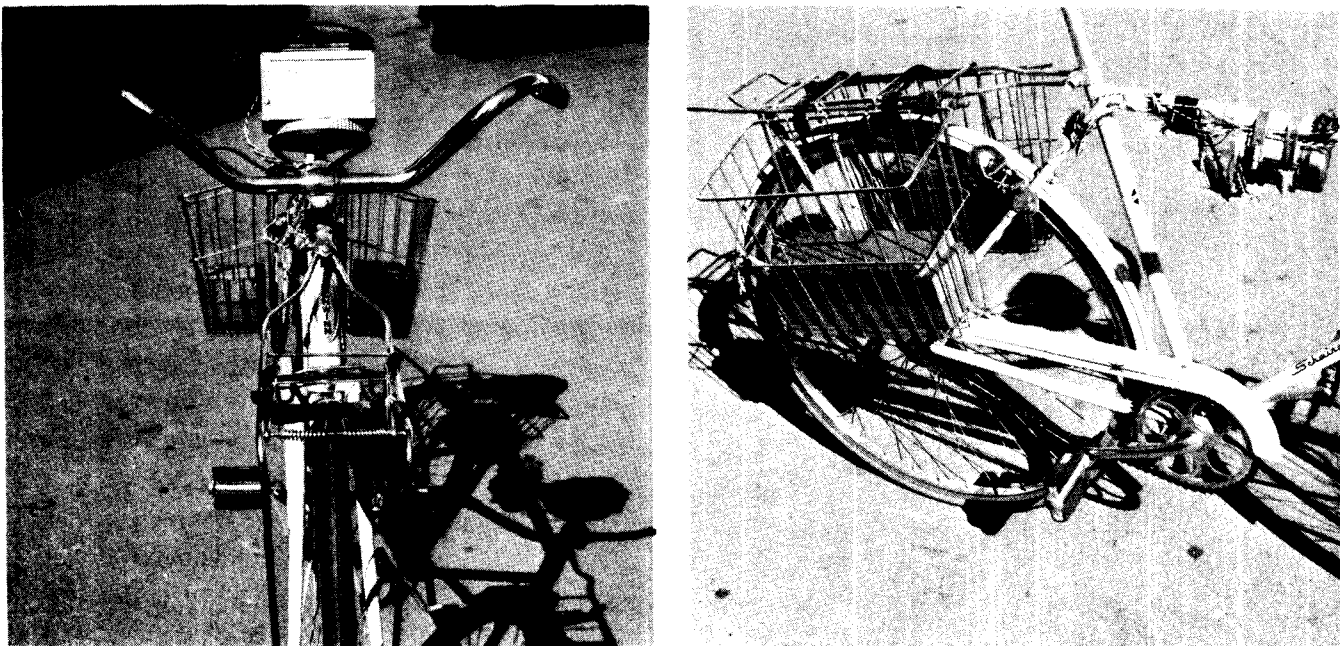

Figure 4.3 25 POUND LOAD IN REAR BASKETS

F. Load in Rear Baskets - Standard bicycle with a 25 pound load evenly distributed and rigidly contained in left and right rear wire baskets. Each basket contained a 12.5 pound wooden block approximately 4 inches wide, 12 inches high and 10 inches wide. The c.g. of each block was approximately 5 inches from the plane of the bicycle, 6 inches above and 1 inch in front of the rear wheel center, Figure 4.3.

G. Load on Front Carrier - Standard bicycle with a 25 pound load rigidly mounted on the front luggage carrier. The load block was the same one used on the rear carrier. The c.g. of the load was in the plane of the front wheel, and approximately 7 inches in front of the steer axis and 19 inches above the front wheel center.

H. Load on Front and Rear Carriers - Standard bicycle with a 25 pound load evenly distributed and rigidly mounted on the front and rear luggage carriers. Each carrier held a lead filled wooden block weighing 12.5 pounds. The blocks were approximately 4 inches wide, 4 inches high and 12 inches long. The c.g. of the front block was approximately 7 inches in front of the steer axis and 18 inches above the front wheel center. The c.g. of the rear block was approximately 18 inches above and 1 inch behind the rear wheel center, Figure 4.1.

I. Load in Rider's Backpack - Standard bicycle with a 25 pound load carried in a small pack on the rider's back.

4.3 Test Results

Approximately two hundred runs were performed with the instrumented bicycle, plus many practice runs without recording data. For each maneuver and bicycle configuration several sequential runs were

made with increasing level of difficulty (increasing or decreasing speed). When the test rider was satisfied that he could not successfully perform the maneuver at a higher level of difficulty the next bicycle configuration and/or maneuver was tested.

Appendix II contains data records for the different bicycle configurations and maneuvers. These records were selected on the basis of being most representative of the runs for the respective configuration and maneuver. Furthermore, all data records in Appendix II represent successful maneuvers, i. e., no pylons were run over, nor was the obstacle hit in the obstacle avoidance maneuver.

Low Speed Stability - With all bicycle configurations the rider was able to stay within the one foot wide lane at near walking speeds of 3 to 4 mph. However, the difficulty in maintaining stability varied considerably among bicycle configurations. Figures II.27 through II.35 of Appendix II show data records for the low speed stability maneuver. These records were selected with the speeds in the 3 to 4 mph range so that steering activity can be used as a relative measure of the difficulty in stabilizing the various bicycle configurations. Note that the signal filtering on the lateral acceleration data is different runs, therefore caution should be used in comparing these data.

The data show that the bicycle was most stable with the high spin moment of inertia front wheel. This conclusion was also supported experimentally by observed improvements in stability when riding hands-off. The most difficult configuration to ride stably at low speed was with the twenty-five pound load in the back pack. It was found that with the load on his back the rider's ability to control the bicycle by leaning was greatly hindered. Figure II.33 shows that the rider had considerable difficulty in

controlling the bicycle with the twenty-five pound load on the front carrier. This load mounted over the front wheel in front of the steer axis greatly increased the moment of inertia about the steer axis making rapid steer corrections very difficult. The data show that the most stable loaded bicycle configuration was with the load on the rear. However, there is little difference in steering activity between runs in which the load was on the rear carrier and in the rear baskets. Lowering the inflation pressure in the front or rear tires had little effect on the low speed stability of the bicycle.

Obstacle Avoidance - Figures II.18 through II.26 of Appendix II show data records of the obstacle avoidance maneuver. These records were selected with speeds in the 11 to 13 mph range and all the records shown were successful runs. In this maneuver there was little difference in the controllability among the standard, the high spin moment of inertia front wheel, and the reduced front and rear tire pressure bicycle configurations. However, the addition of the twenty-five pound load affected the maneuverability to varying degrees depending upon the location of the load. Undoubtedly, the worst configurations for the load were again in the backpack and on the front carrier. Figures II.24 and II.26 show that for these two configurations the rider's steering input was very irregular. Furthermore, the third hump in the lateral acceleration curves for these runs show that additional corrective action was required to stabilize the bicycle after the obstacle was avoided. The loaded bicycle configuration in which the maneuver was performed most easily was with the load in the rear baskets. The lateral acceleration curve for this configuration, Figure II.23 is very smooth compared with the other load configurations.

Narrow and Wide Slalom Courses - Figures II.1 through II.17 of Appendix II show data records for the narrow and wide slalom courses. These records represent the highest speed at which each maneuver was

successfully run. Figure 4.4 shows the speeds for all attempted (successes and failures) slalom maneuvers for the nine bicycle configurations. These maneuvers showed good discrimination between bicycle configurations based on the maximum successful speed. It is interesting that the rank order of the maximum successful speeds is the same for the narrow and the wide courses. The average maximum successful speed for the wide course is about 4 mph slower than for the narrow course. Figure 4.4 shows that in both maneuvers the performance of the bicycle was degraded by any changes from the standard bicycle configurations.

As in the previous maneuvers the two worst bicycle configurations are those with the load on the front carrier and in the rider's backpack. The configuration with the load on the front carrier is conspicuously slower than any other configuration for both slalom courses. The high spin moment of inertia front wheel had little effect on the maneuverability of the bicycle in the slalom course. The best speeds for this configuration were almost equal to the best speed with the standard bicycle.

The maximum successful speeds with the reduced front or rear tire pressure configurations were lower than the standard bicycle; however, they were generally a little faster than the average maximum successful speed of the loaded configurations. Although the performance of the bicycle was degraded by the reduction in tire pressure (at one end or the other) the bicycle was certainly controllable. In fact, it was more stable than would be expected for such an extreme front to rear bias in inflation pressure.

The most maneuverable loaded bicycle configuration was with the load in the rear baskets. The slalom runs showed a definite performance

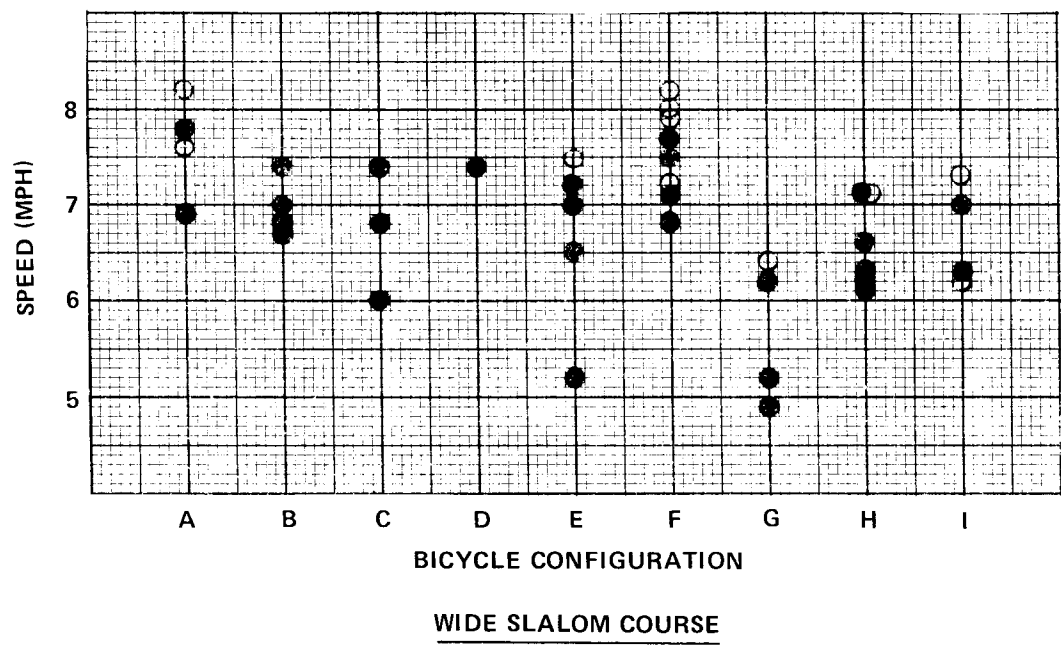
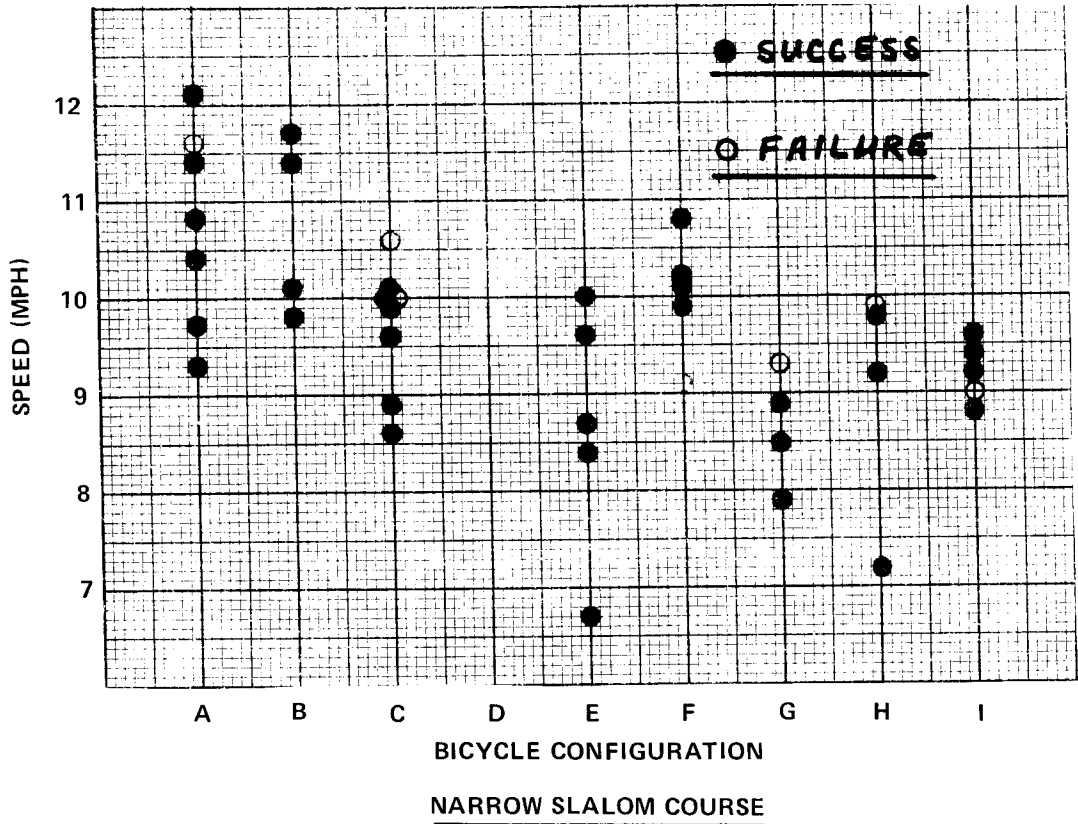

Figure 4.1 SUMMARY OF RESULTS FOR SLALOM COURSE MANEUVERS

improvement in moving the load from the rear carrier down to the rear side baskets. This indicates the best luggage carrier design might be side baskets mounted on the rear as near to the ground as practical.

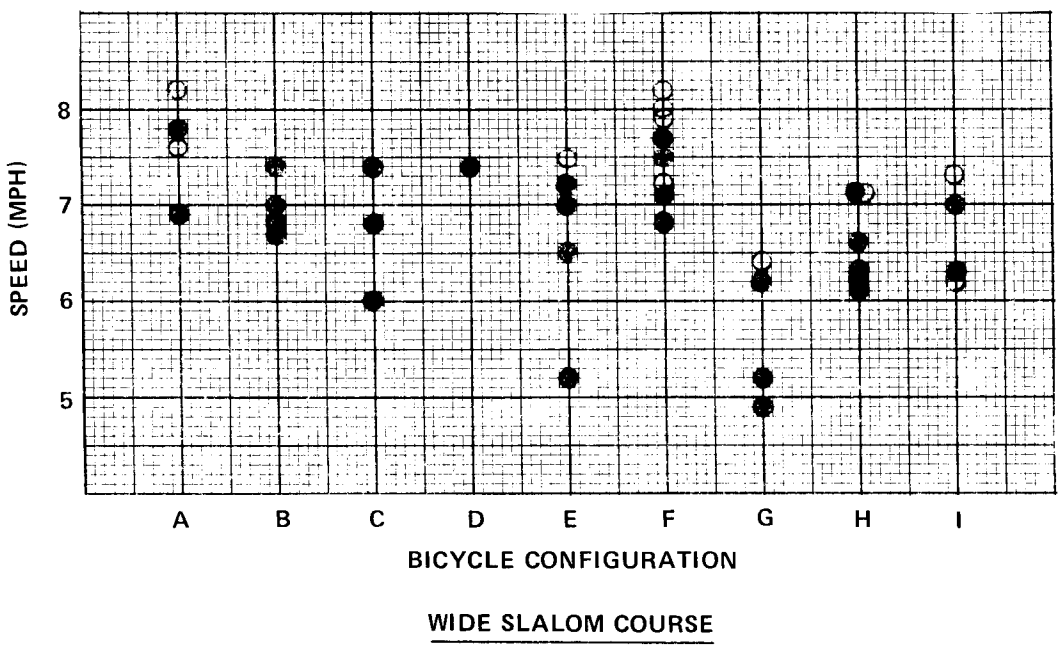
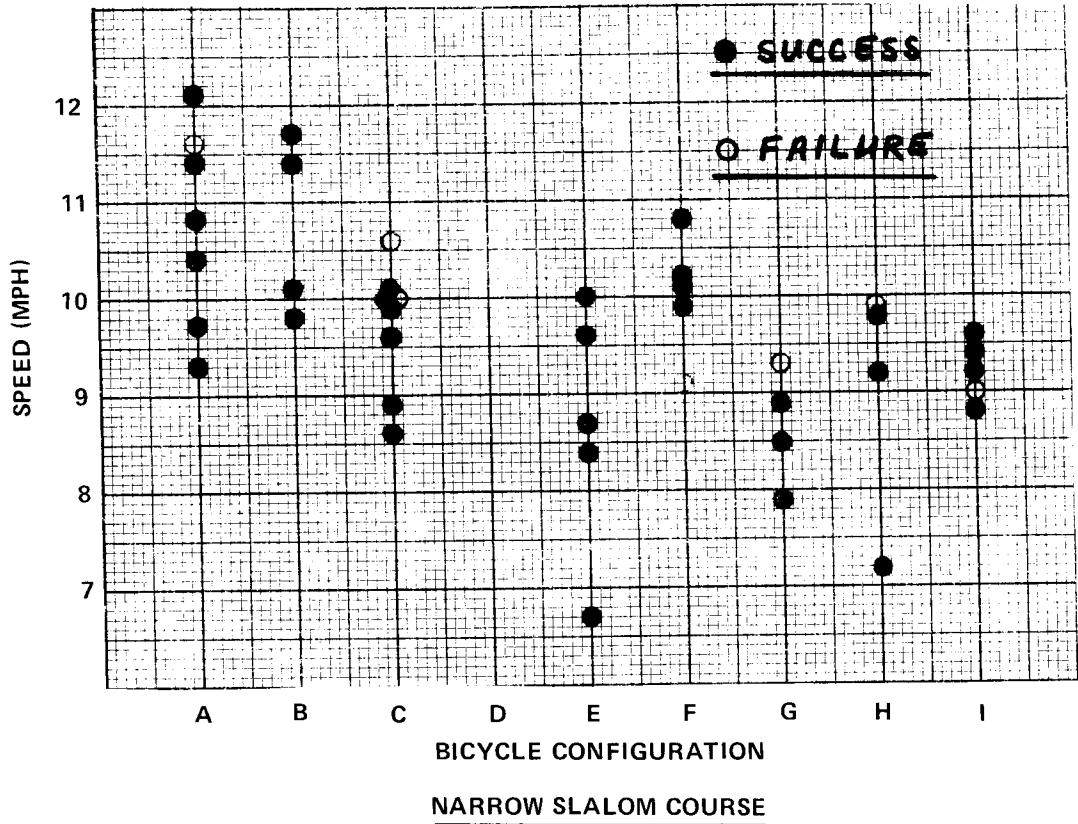

Figure 4.1 SUMMARY OF RESULTS FOR SLALOM COURSE MANEUVERS

improvement in moving the load from the rear carrier down to the rear side baskets. This indicates the best luggage carrier design might be side baskets mounted on the rear as near to the ground as practical.

5.0 COMPUTER GRAPHICS ANIMATION OF THE BICYCLE SIMULATION

For years, printed output was the only means of communication between the computer and man. This limitation dictated that only the technically skilled could interpret the reams of computer printout with its lists of numbers and specialized codes. However, computer designers learned that the computer, which normally generated control signals to command a printer to print a letter, could also be designed to generate control signals to move the beam of a cathode ray tube. Obviously, a sequence of beam movements controlled by the computer can trace a picture. This new capability of drawing a picture opened up a new area of computer application, generally referred to as computer graphics. Computer graphics is, in the strictest sense, a pictorial representation of computer data.

Cornell Aeronautical Laboratory has been very active in the field of computer graphics. This activity ranges from everyday use of plotting facilities by most programmers to highly complex computer-generated radar displays. One of the more fascinating computer graphics applications has been the Transportation Research Department's Single Vehicle Accident Display Program, developed by Calvin Theiss. Developed for the U. S. Department of Commerce, Bureau of Public Roads, Contract No. CPR-11-3988, this program converts automobile dynamics simulation data into a pictorial representation of the event. A unique feature of this program is that sequences of the computer-generated pictures can be combined to make an animated motion picture film of the event. Computer specialists would refer to this program as a specialized three dimensional perspective graphics package with both single frame and movie outputs. The Single Vehicle Accident Display Program provided the basis of the Schwinn Bicycle Graphics Program.

5.1 Features of the Computer Graphics Program

The Schwinn Bicycle Graphics Program provides its users with a complete and flexible perspective graphics package to document pictorially the results of a bicycle simulation. The salient features of the Schwinn Bicycle Graphics Program are:

- A) The program can plot a perspective picture of a bicycle and rider, positioned and oriented as per the simulation data.
- B) The line drawing representation of the bicycle and rider can be easily changed to fit simulation or esthetic requirements.
- C) The program can produce single pictures (for the Houston or Calcomp plotters) or animated movies (Flying Spot Scanner and 16 mm movie camera).
- D) Background objects, such as roadways, houses, obstacles, etc. can be stored and plotted in the scene.
- E) For animated films, the "frame rate" can be adjusted for "slow motion" or normally timed action.
- F) The program is written to simulate a 16 mm camera, so that visualization of a scene is accomplished by specifying a set of standard camera parameters.
- G) The scene may be viewed from any point in space, at any angle, and at any focal length.
- H) The program's "camera" can be set to automatically pan, zoom, remain fixed, or operate as on a movable base.
- I) The program has a "double exposure" capability.

- J) Simple, straight-line maneuvers which act as a lead-in to the simulated maneuver can be done without simulation data.
- K) Titles and sub-titles can be placed anywhere in the picture sequence.
- L) Any of the above characteristics can be changed during a run.

5.2 Bicycle Motions Simulated

The Schwinn Bicycle Simulation generates a "dynamics tape" which contains most of the information needed to run the graphics program. At each simulation time increment (1/1000th of a second, for instance) the bicycle c. g. position (X, Y, Z coordinates), orientation (yaw, roll, and pitch angles), steer angle, and rider lean angle is stored on the tape. All other pertinent information, such as front fork angle, rider "hunch forward" angle, etc. are input once to the program as data cards, along with the stored three dimensional line drawings of the bicycle and rider.

The bicycle graphics program searches the tape and finds the simulation time corresponding to the desired "frame time." This information is then extracted to draw the desired picture. The program mathematically combines the chassis, front fork, and pedals to draw the bicycle, and mathematically combines the torso, left and right upper arms and forearms, and left and right thighs, calves, and feet to draw the rider. Everything is so combined as to yield a picture of a rider astride a bicycle assuming normal pedaling, leaning, and handlebar grip, Figure 5.1. Obviously, animation is obtained if in succeeding frames the elements of the bicycle and rider are mathematically juxtaposed so as to simulate real life actions, Figure 5.2. Consequently, the bicycle actions that are simulated are:

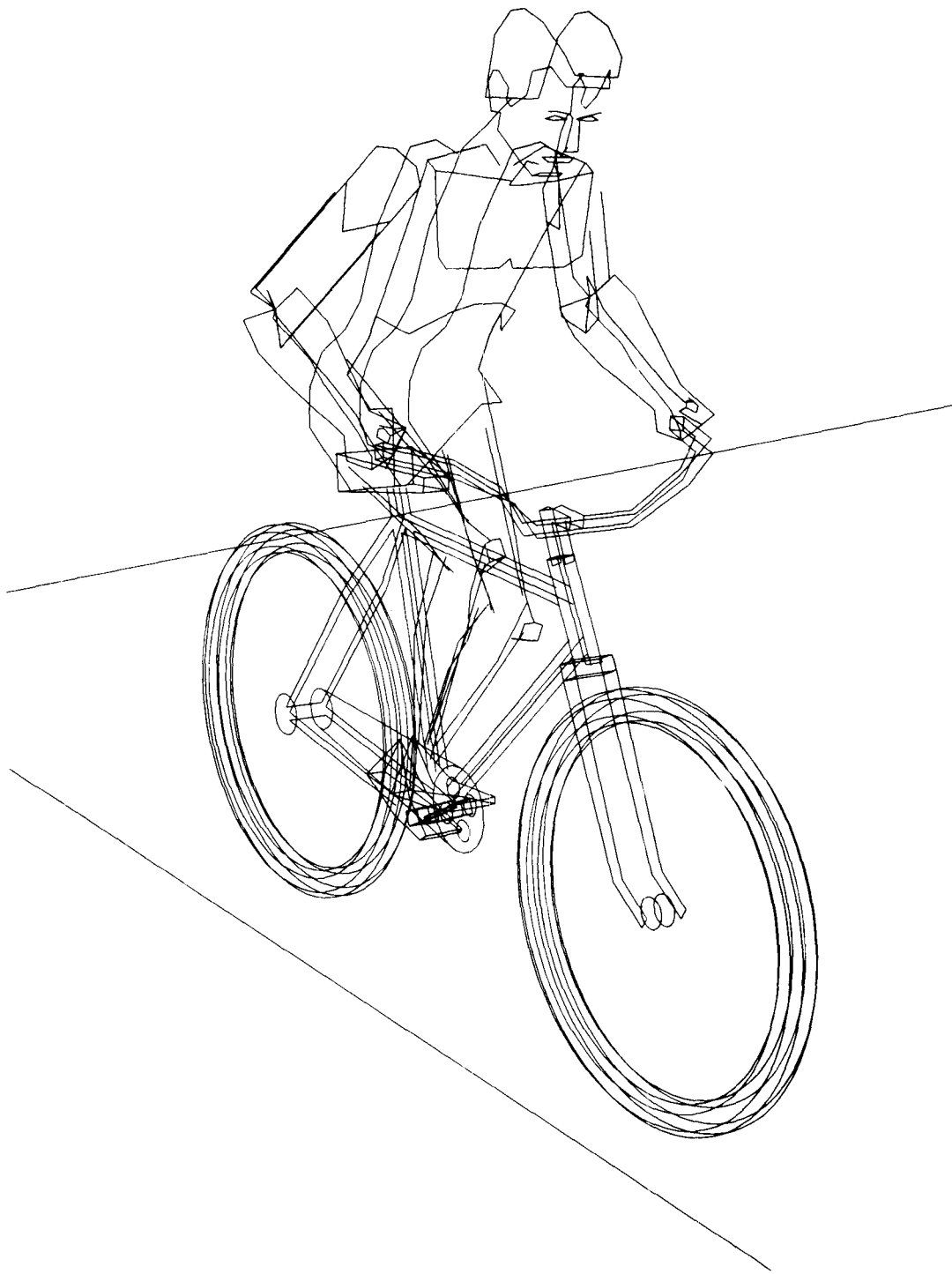

Figure 5.1 COMPUTER GRAPHICS RENDITION OF A BICYCLE AND RIDER



EXPERIMENTAL

5.8 SEC

6.0 SEC

6.2 SEC

6.4 SEC

6.6 SEC

6.8 SEC

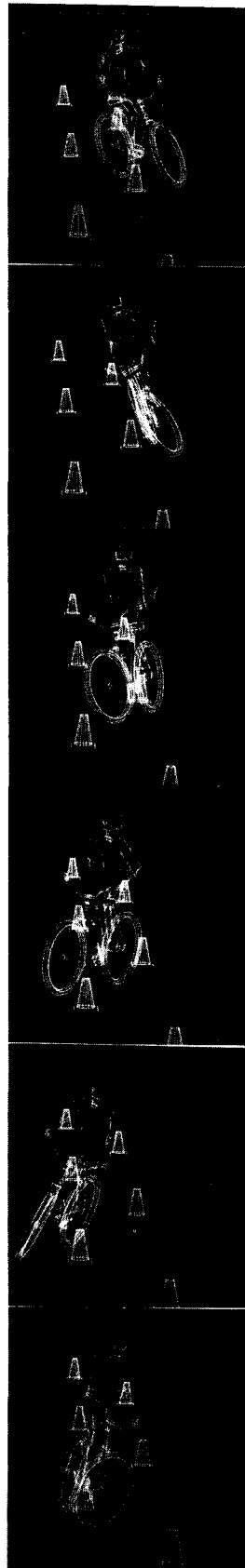

SIMULATED

Figure 5.2 BICYCLE SLALOM MANEUVER

- (1) Bicycle chassis translation and rotation (6 degrees-of-freedom)
- (2) Front fork and handlebar system steering action
- (3) Circular pedal rotation
- (4) Rider left-right lean action
- (5) Rider arm steering action
- (6) Rider leg pedaling action
- (7) Rider ankle motion

Full details of how these actions are programmed is included in Appendix 3.

5.3 Cost of Bicycle Graphics

The Schwinn Bicycle Graphics Program costs about \$5.00 for two plots and from 50¢ to 90¢ per frame for animated films. The cost is generally proportional to the number of lines drawn. Therefore, simpler backgrounds and line drawings of the bicycle and rider tend to reduce the cost per frame.

5.4 The Mechanics of Making a Graphics Movie

The basic ingredient of a Schwinn Bicycle Computer Movie is the simulation program. The simulation program predicts the performance of the bicycle under a predetermined set of conditions. The investigator may inspect the results of the simulation run by referring to the printed output generated by the simulation program. The simulation program also produces a magnetic tape which contains the simulation results and which is used by the Schwinn Bicycle Graphics Program.

This "dynamics tape" is input to the graphics program, concurrently with data cards specifying bicycle size, outline, camera data, run time, etc. The bicycle graphics program then sequentially obtains the dynamics data as needed, mathematically transforms the stored line drawings into a scene representative of the simulated position and orientation of the bicycle and rider as viewed from the requested camera position.

An interface program converts the final line drawings, as stored in the computer, into a set of commands for the CAL Flying Spot Scanner. The cathode ray tube beam of the Flying Spot Scanner traces out one frame of the movie while a 16 mm movie camera records the picture. Upon completion of the frame, the film is automatically advanced, the graphics program reads the next data (positions, angles, etc. of bike and rider) from the dynamics tape and draws the next picture on the cathode ray tube. The completed film will show animated movement, exactly as the simulation predicted. Figure 5.3 illustrates the movie making process.

5.5 Future Developments in Computer Graphics

While the current cost of making computer-generated animated films is quite high at the time of the release of this report, past experience in the computer industry indicates that the cost will be markedly reduced. The change from the 360 series to the 370 series of computers brought four times the computing power with only a small increase in costs. Thus, the next generation of machines will give a very large price reduction. In the near term, certain modifications to the CAL Flying Spot Scanner to allow its commands to be supplied off-line from magnetic tape rather than directly from the central computer will reduce the real-time memory space rental charge incurred by the present method. This improvement could yield a

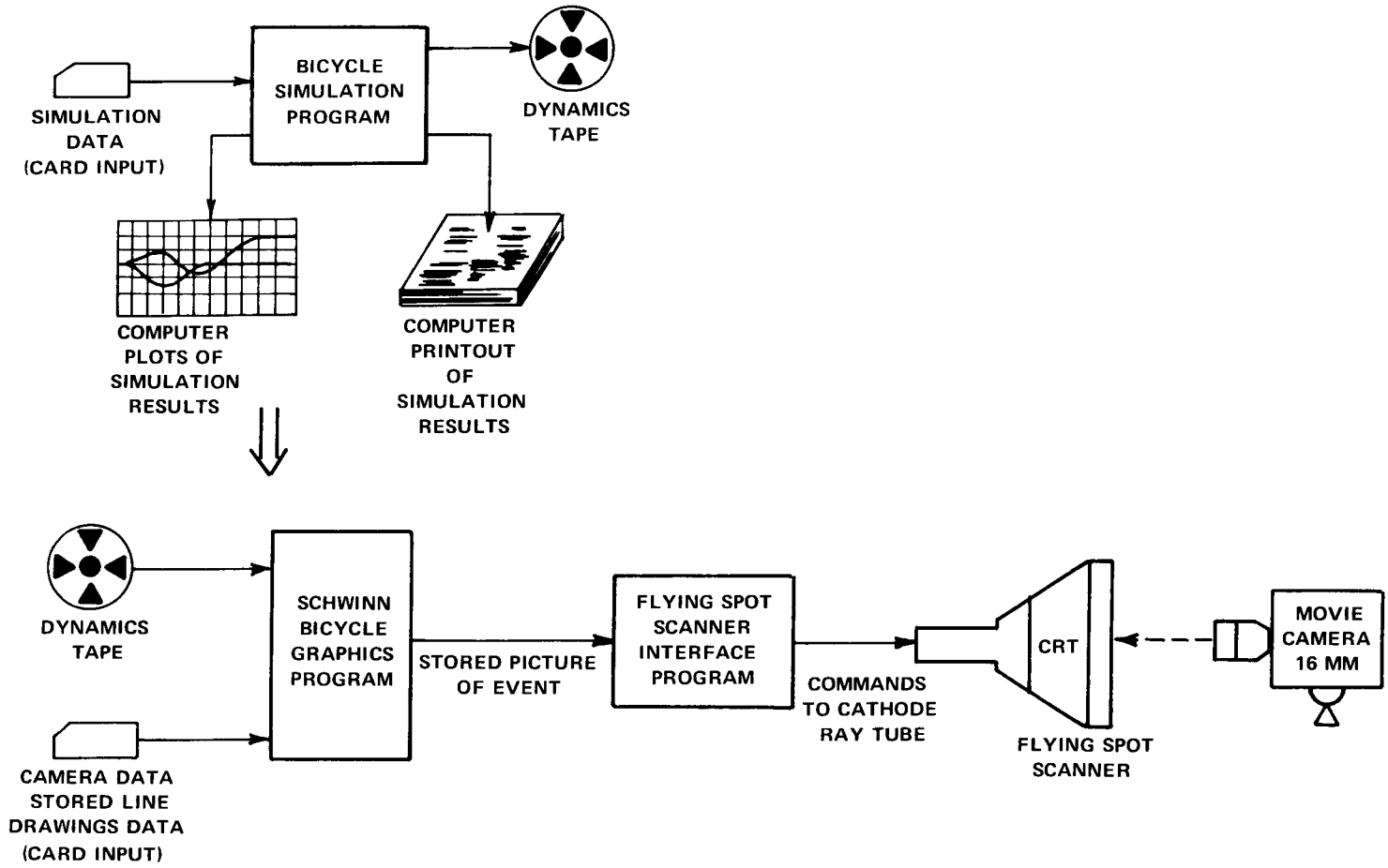

Figure 5.3 STEPS IN MAKING SCHWINN BICYCLE MOVIE

20% cost reduction. As computers grow in power, speed, and economy of operation, this type of graphic output will change from a demonstration tool for the technically unskilled to a "first look" tool to be used by the design engineers.

The same pictures that are plotted on the Flying Spot Scanner or the Houston plotter can also be plotted on a computer terminal with a visual display system. The main advantage of the computer terminal approach is that an interactive simulation/graphics program could be developed. Through the terminal's keyboard, the bicycle designer can supply some particular bicycle parameters of interest, start the simulation, and display some frames of the simulation as it progresses. If the simulation pictures show the bicycle to be performing in an unsatisfactory way, then the designer can stop the simulation (thus saving wasted run time), re-input some new bicycle parameters, and start the process again. It is clear that this interactive process is an efficient way to use simulation as a design tool. In the future it will be possible to implement this system with one of the new, powerful minicomputers becoming available, at the factory where the design is being done.

As far as improvements to the present program go, short of arranging the rider to dismount the bicycle and walk away, the hidden line problem is the only one of major importance. The hidden line problem refers to being able to see through a three dimensional line drawing and observe lines on the other side that are normally invisible. Computerized hidden line removal techniques are available, but at enormous costs in computing time. Such a capability would be esthetically pleasing in the Schwinn Bicycle Graphics Program but quite costly. It is felt that the capability should be available and it would receive much usage in the still

picture generation. However, present computing costs prohibit its usage in animated films until the next generation of computing equipment. The same may be said for computer generated half-tone color prints. These capabilities should be investigated and developed now with an eye on the future where their usage will be cost effective.

6.0 BIBLIOGRAPHY

1. Roland, R. D., Jr. and Massing, D. E.: "A Digital Computer Simulation of Bicycle Dynamics" - Cornell Aeronautical Laboratory, Inc., Technical Report No. YA-3063-K-1, June 1971.
2. Van Lunteren, A. and Stassen, H. F.: "Annual Report of the Man-Machine Systems Group" - Laboratory for Measurement and Control, Dept. of Mech. Eng., Delft University of Technology, 1970.
3. Van Lunteren, A. and Stassen, H. G.: "Investigations of the Characteristics of a Human Operator Stabilizing a Bicycle Model" - Intern. Symp. on Ergonomics in Machine Design, Prague, 1967.
4. Van Lunteren, A. and Stassen, H. G.: "On-Line Parameter Estimation of the Human Transfer in a Man-Bicycle System" - IVth IFAC Congress, Warsaw, 1969, Paper 70.3.
5. Van Lunteren, A. and Stassen, H. G.: "On the Variance of the Bicycle Rider's Behavior" - 6th Annual Conference on Manual Control, Wright Patterson Air Force Base, Ohio, 1970.
6. Elkind, J. I.: "Characteristics of Simple Manual Control Systems" - Massachusetts Institute of Technology, Lincoln Laboratory Technical Report No. 111, April 1956.
7. Kroll, C. V. and Roland, R. D., Jr.: "A Preview-Predictor Model of Driver Behavior in Emergency Situations" - Prepared for U.S. Department of Transportation by Cornell Aeronautical Laboratory, Inc., CAL Report No. VJ-2251-V-6, October 1970.

8. Theiss, C. M.: "Perspective Picture Output for Automobile Dynamics Simulation" - Cornell Aeronautical Laboratory, Inc., CAL Report No. VJ-2251-V-2R, January 1969.

Appendix I

MEASURED AND CORRECTED TIRE DATA

24" SCHWINN FASTRACK SLIK

SLIP ANGLE RIAS = 1.068

MEASURED SLIP ANGLE	CORRECTED SLIP ANGLE	MEASURED INCLINATION ANGLE	CORRECTED INCLINATION ANGLE	NORMAL FORCE	MEASURED LATERAL FORCE	CORRECTED LATERAL FORCE
-3.000	-2.976	0.0	0.646	37.150	-27.000	-27.369
-3.000	-2.437	0.0	0.965	70.250	-40.000	-40.887
-3.000	-2.238	0.0	1.083	104.500	-44.250	-45.876
-3.000	-3.108	10.000	10.568	37.150	-23.750	-24.065
-3.000	-2.670	10.000	10.822	70.250	-34.000	-34.813
-3.000	-2.480	10.000	10.939	104.500	-38.250	-39.801
-3.000	-3.079	20.000	20.585	37.150	-24.500	-24.792
-3.000	-2.700	20.000	20.809	70.250	-33.500	-34.290
-3.000	-2.511	20.000	20.921	104.500	-37.500	-39.016
-3.000	-3.120	30.000	30.561	37.150	-23.500	-23.755
-3.000	-2.782	30.000	30.761	70.250	-31.500	-32.236
-3.000	-2.593	30.000	30.873	104.500	-35.500	-36.972
-3.000	-3.101	40.000	40.572	37.150	-24.000	-24.730
-3.000	-2.803	40.000	40.748	70.250	-31.000	-31.703
-3.000	-2.735	40.000	40.789	104.500	-32.000	-33.416
-2.000	-2.167	0.0	0.533	37.150	-22.250	-22.583
-2.000	-1.829	0.0	0.733	70.250	-30.250	-31.063
-2.000	-1.710	0.0	0.803	104.500	-32.500	-34.036
-2.000	-2.269	10.000	10.473	37.150	-19.750	-20.035
-2.000	-1.960	10.000	10.655	70.250	-27.000	-27.759
-2.000	-1.822	10.000	10.737	104.500	-29.750	-31.236
-2.000	-2.280	20.000	20.466	37.150	-19.500	-19.754
-2.000	-2.022	20.000	20.619	70.250	-25.500	-26.219
-2.000	-1.883	20.000	20.701	104.500	-28.250	-29.696
-2.000	-2.321	30.000	30.442	37.150	-18.500	-18.717
-2.000	-2.107	30.000	30.571	70.250	-23.500	-24.175
-2.000	-2.015	30.000	30.623	104.500	-25.000	-26.392
-2.000	-2.383	40.000	40.405	37.150	-17.000	-17.177
-2.000	-2.286	40.000	40.463	70.250	-19.000	-19.611
-2.000	-2.257	40.000	40.479	104.500	-19.000	-20.317
-1.000	-1.328	0.0	0.438	37.150	-18.250	-18.552
-1.000	-1.170	0.0	0.531	70.250	-21.750	-22.498
-1.000	-1.092	0.0	0.577	104.500	-23.000	-24.464
-1.000	-1.450	10.000	10.366	37.150	-15.250	-15.500
-1.000	-1.322	10.000	10.441	70.250	-18.000	-18.690
-1.000	-1.256	10.000	10.482	104.500	-19.000	-20.404
-1.000	-1.461	20.000	20.359	37.150	-15.000	-15.219
-1.000	-1.346	20.000	20.429	70.250	-17.500	-18.158
-1.000	-1.295	20.000	20.457	104.500	-18.000	-19.368
-1.000	-1.462	30.000	30.358	37.150	-15.000	-15.190
-1.000	-1.355	30.000	30.422	70.250	-17.250	-17.877
-1.000	-1.327	30.000	30.439	104.500	-17.250	-18.583
-1.000	-1.463	40.000	40.358	37.150	-15.000	-15.161
-1.000	-1.406	40.000	40.391	70.250	-16.000	-16.588
-1.000	-1.510	40.000	40.325	104.500	-12.500	-13.768
0.0	-0.650	0.0	0.242	37.150	-10.000	-10.239
0.0	-0.623	0.0	0.263	70.250	-10.500	-11.162
0.0	-0.584	0.0	0.286	104.500	-10.750	-12.120
0.0	-0.721	10.000	10.205	37.150	-9.500	-9.699
0.0	-0.664	10.000	10.239	70.250	-9.500	-10.126
0.0	-0.716	10.000	10.208	104.500	-7.500	-8.816
0.0	-0.632	20.000	20.228	37.150	-9.500	-9.677
0.0	-0.645	20.000	20.250	70.250	-10.000	-10.601
0.0	-0.657	20.000	20.243	104.500	-9.000	-10.299
0.0	-0.683	30.000	30.228	37.150	-9.500	-9.648
0.0	-0.707	30.000	30.214	70.250	-9.500	-9.060
0.0	-0.799	30.000	30.159	104.500	-5.500	-6.743
0.0	-0.684	40.000	40.227	37.150	-9.500	-9.619
0.0	-0.768	40.000	40.177	70.250	-7.000	-7.520
0.0	-0.881	40.000	40.111	104.500	-3.500	-4.699
0.0	-0.670	0.0	0.236	37.150	-9.750	-9.987
0.0	-0.623	0.0	0.263	70.250	-10.500	-11.162
0.0	-0.554	0.0	0.304	104.500	-11.500	-12.876
0.0	-0.671	10.000	10.235	37.150	-9.750	-9.958
0.0	-0.634	10.000	10.257	70.250	-10.250	-10.881
0.0	-0.626	10.000	10.262	104.500	-9.750	-11.084
0.0	-0.642	20.000	20.252	37.150	-10.500	-10.685
0.0	-0.565	20.000	20.298	70.250	-12.000	-12.616
0.0	-0.536	20.000	20.314	104.500	-12.000	-13.322
0.0	-0.663	30.000	30.240	37.150	-10.000	-10.152
0.0	-0.606	30.000	30.273	70.250	-11.000	-11.579
0.0	-0.635	30.000	30.254	104.500	-9.500	-10.774
0.0	-0.744	40.000	40.191	37.150	-8.000	-8.108
0.0	-0.778	40.000	40.172	70.250	-6.750	-7.268
0.0	-0.901	40.000	40.099	104.500	-3.000	-4.195
1.000	-0.062	0.0	0.004	37.150	0.0	-0.163
1.000	-0.065	0.0	0.002	70.250	0.500	-0.078
1.000	-0.067	0.0	0.001	104.500	1.250	-0.029
1.000	-0.027	10.000	10.027	37.150	-1.000	-1.141
1.000	-0.066	10.000	10.001	70.250	0.500	-0.049
1.000	-0.158	10.000	9.946	104.500	3.500	2.268
1.000	0.057	20.000	20.074	37.150	-3.000	-3.128
1.000	0.023	20.000	20.054	70.250	-1.750	-2.288
1.000	-0.029	20.000	20.023	104.500	0.250	-0.978
1.000	0.096	30.000	30.097	37.150	-4.000	-4.106
1.000	0.012	30.000	30.047	70.250	-1.500	-2.027
1.000	-0.100	30.000	29.981	104.500	2.000	0.814
1.000	0.034	40.000	40.061	37.150	-2.500	-2.566
1.000	-0.110	40.000	39.975	70.250	1.500	1.045

74" SCHWINN FASTRACK SLIK

MEASURED SLIP ANGLE	CORRECTED SLIP ANGLE	MEASURED INCLINATION ANGLE	CORRECTED INCLINATION ANGLE	NORMAL FORCE	MEASURED LATERAL FORCE	CORRECTED LATERAL FORCE
1.000	-0.262	40.000	39.885	104.500	6.000	4.873
2.000	0.637	0.0	-0.175	37.150	7.500	7.394
2.000	0.523	0.0	-0.242	70.250	10.750	10.250
2.000	0.501	0.0	-0.255	104.500	12.000	10.803
2.000	0.476	10.000	9.849	37.150	6.500	6.416
2.000	0.562	10.000	9.781	70.250	9.750	9.271
2.000	0.510	10.000	9.750	104.500	11.750	10.580
2.000	0.906	20.000	19.985	37.150	0.750	0.651
2.000	0.812	20.000	19.929	70.250	3.500	3.002
2.000	0.914	20.000	19.374	104.500	6.500	5.319
2.000	0.806	20.000	19.989	37.150	0.550	0.449
2.000	0.726	20.000	19.926	70.250	3.650	3.154
2.000	0.875	30.000	19.878	104.500	6.350	5.168
2.000	0.771	30.000	29.966	37.150	1.500	1.435
2.000	0.838	30.000	29.905	70.250	4.500	4.039
2.000	0.853	40.000	29.876	104.500	8.500	7.364
2.000	0.669	40.000	39.954	37.150	2.000	1.968
2.000	0.446	40.000	19.945	70.250	7.000	6.587
3.000	1.755	0.0	19.713	104.500	13.250	12.179
3.000	1.091	0.0	-0.400	37.150	17.000	16.967
3.000	1.018	0.0	-0.498	70.250	21.500	21.082
3.000	1.314	0.0	-0.540	104.500	24.000	22.895
3.000	1.049	10.000	9.635	37.150	15.500	15.484
3.000	0.937	10.000	9.479	70.250	22.500	22.118
3.000	1.494	10.000	9.411	104.500	26.000	24.939
3.000	1.779	20.000	19.741	37.150	11.000	10.979
3.000	1.127	20.000	19.614	70.250	16.750	16.354
3.000	1.503	20.000	19.574	104.500	21.250	20.182
3.000	1.768	30.000	29.746	37.150	10.750	10.756
3.000	1.095	30.000	29.607	70.250	17.000	16.634
3.000	1.492	30.000	29.505	104.500	22.000	20.967
3.000	1.008	40.000	39.740	37.150	11.000	11.037
3.000	1.187	40.000	39.559	70.250	19.000	18.679
3.000	0.893	40.000	39.386	104.500	27.000	26.034
4.000	2.054	0.0	-0.519	37.150	22.000	22.005
4.000	1.769	0.0	-0.688	70.250	29.500	29.143
4.000	1.616	0.0	-0.778	104.500	34.000	32.971
4.000	2.053	10.000	9.480	37.150	22.000	22.034
4.000	1.738	10.000	9.294	70.250	30.250	29.928
4.000	1.575	10.000	9.197	104.500	35.000	34.008
4.000	2.353	20.000	19.658	37.150	14.500	14.506
4.000	2.058	20.000	19.483	70.250	22.250	21.895
4.000	1.865	20.000	19.369	104.500	27.750	26.731
4.000	2.352	30.000	29.657	37.150	14.500	14.535
4.000	2.057	30.000	29.483	70.250	22.250	21.924
4.000	1.784	30.000	29.321	104.500	29.750	28.776
4.000	2.331	40.000	39.644	37.150	15.000	15.067
4.000	2.006	40.000	39.452	70.250	23.500	23.213
4.000	1.732	40.000	39.290	104.500	31.000	30.064
6.000	3.873	0.0	-0.626	37.150	26.500	26.539
6.000	3.206	0.0	-1.071	70.250	43.500	43.250
6.000	2.913	0.0	-1.194	104.500	51.500	50.605
6.000	3.932	10.000	9.409	37.150	25.000	25.057
6.000	3.105	10.000	8.919	70.250	46.000	45.798
6.000	2.851	10.000	8.769	104.500	53.000	52.145
6.000	3.971	20.000	19.437	37.150	24.000	24.078
6.000	3.445	20.000	19.121	70.250	37.500	37.262
6.000	3.132	20.000	19.935	104.500	46.000	45.121
6.000	3.970	30.000	29.431	37.150	24.000	24.107
6.000	3.484	30.000	29.144	70.250	36.500	36.283
6.000	3.151	30.000	29.946	104.500	45.500	44.646
6.000	3.929	40.000	39.407	37.150	25.000	25.144
6.000	3.383	40.000	39.084	70.250	39.000	38.831
6.000	3.009	40.000	38.862	104.500	49.000	48.201
8.000	5.933	0.0	-0.591	37.150	25.000	25.028
8.000	4.924	0.0	-1.247	70.250	53.000	52.822
8.000	4.330	0.0	-1.539	104.500	66.000	65.215
8.000	6.013	10.000	9.456	37.150	23.000	23.042
8.000	4.662	10.000	9.658	70.250	57.000	56.882
8.000	4.188	10.000	8.377	104.500	69.500	68.771
8.000	5.851	20.000	19.360	37.150	27.000	27.101
8.000	4.923	20.000	18.911	70.250	50.500	50.361
8.000	4.448	20.000	18.531	104.500	63.000	62.250
8.000	5.870	30.000	29.372	37.150	26.500	26.626
8.000	5.102	30.000	28.918	70.250	46.000	45.856
8.000	4.568	30.000	28.602	104.500	60.000	59.256
8.000	5.808	40.000	39.335	37.150	23.000	23.167
8.000	5.001	40.000	38.858	70.250	43.500	43.404
8.000	4.406	40.000	38.506	104.500	64.000	63.316
10.000	8.014	0.0	-0.543	37.150	23.000	23.013
10.000	6.664	0.0	-1.342	70.250	57.000	56.853
10.000	5.928	0.0	-1.777	104.500	76.000	75.292
10.000	8.012	10.000	9.456	37.150	23.000	23.042
10.000	6.602	10.000	8.622	70.250	58.500	58.393
10.000	5.706	10.000	8.292	104.500	81.500	80.863
10.000	7.891	20.000	19.184	37.150	26.000	26.093
10.000	6.681	20.000	18.669	70.250	56.500	56.407
10.000	5.926	20.000	18.222	104.500	76.000	75.350
10.000	7.950	30.000	29.360	37.150	27.000	27.130
10.000	6.781	30.000	28.728	70.250	54.000	53.917
10.000	6.005	30.000	29.269	104.500	74.000	73.363
10.000	7.748	40.000	39.300	37.150	29.500	29.678
10.000	6.800	40.000	38.739	70.250	53.500	53.442
10.000	5.923	40.000	38.220	104.500	76.000	75.477

SCHWINN 24X1-1/4 RREEZF SPORTS TOURING (CARLISLE, JUNE 71, WESTRICK RIM)

SLIP ANGLE BIAS = 1.178

MEASURED SLIP ANGLE	CORRECTED SLIP ANGLE	MEASURED INCLINATION ANGLE	CORRECTED INCLINATION ANGLE	NORMAL FORCE	MEASURED LATERAL FORCE	CORRECTED LATERAL FORCE
-1.000	-1.327	0.0	0.503	37.150	-21.000	-21.323
-1.000	-2.898	0.0	0.757	70.250	-31.250	-32.071
-1.000	-2.619	0.0	0.927	104.500	-37.500	-39.074
-1.000	-3.308	10.000	10.514	37.150	-21.500	-21.798
-1.000	-2.889	10.000	10.762	70.250	-31.500	-32.293
-1.000	-2.660	10.000	10.898	104.500	-36.500	-38.038
-1.000	-3.269	20.000	20.538	37.150	-22.500	-22.777
-1.000	-2.830	20.000	20.797	70.250	-33.000	-33.776
-1.000	-2.641	20.000	20.909	104.500	-37.000	-38.512
-1.000	-3.331	30.000	30.501	37.150	-21.000	-21.236
-1.000	-2.902	30.000	30.701	70.250	-29.000	-29.717
-1.000	-2.884	30.000	30.766	104.500	-31.000	-32.439
-1.000	-3.272	40.000	40.536	37.150	-22.500	-22.719
-1.000	-2.973	40.000	40.713	70.250	-29.500	-30.191
-1.000	-3.066	40.000	40.658	104.500	-26.500	-27.874
-2.000	-2.468	0.0	0.420	37.150	-17.500	-17.796
-2.000	-2.170	0.0	0.596	70.250	-24.500	-25.269
-2.000	-1.961	0.0	0.720	104.500	-29.000	-30.509
-2.000	-2.469	10.000	10.419	37.150	-17.500	-17.767
-2.000	-2.191	10.000	10.584	70.250	-24.000	-24.736
-2.000	-2.022	10.000	10.684	104.500	-27.500	-28.969
-2.000	-2.450	20.000	20.431	37.150	-18.000	-18.242
-2.000	-2.162	20.000	20.601	70.250	-24.750	-25.463
-2.000	-2.023	20.000	20.683	104.500	-27.500	-28.940
-2.000	-2.491	30.000	30.406	37.150	-17.000	-17.206
-2.000	-2.334	30.000	30.499	70.250	-20.500	-21.152
-2.000	-2.246	30.000	30.551	104.500	-22.000	-23.369
-2.000	-2.452	40.000	40.429	37.150	-18.000	-18.184
-2.000	-2.345	40.000	40.493	70.250	-20.250	-20.871
-2.000	-2.408	40.000	40.456	104.500	-18.000	-19.310
-1.000	-1.639	0.0	0.319	37.150	-13.250	-13.514
-1.000	-1.421	0.0	0.448	70.250	-18.250	-18.971
-1.000	-1.302	0.0	0.518	104.500	-20.500	-21.945
-1.000	-1.650	10.000	10.312	37.150	-13.000	-13.233
-1.000	-1.462	10.000	10.423	70.250	-17.250	-17.935
-1.000	-1.374	10.000	10.676	104.500	-18.750	-20.152
-1.000	-1.581	20.000	20.353	37.150	-14.750	-14.967
-1.000	-1.403	20.000	20.659	70.250	-18.750	-19.417
-1.000	-1.345	20.000	20.493	104.500	-19.500	-20.879
-1.000	-1.652	30.000	30.311	37.150	-13.000	-13.175
-1.000	-1.615	30.000	30.333	70.250	-13.500	-14.098
-1.000	-1.648	30.000	30.314	104.500	-12.000	-13.293
-1.000	-1.653	40.000	40.310	37.150	-13.000	-13.146
-1.000	-1.617	40.000	40.332	70.250	-13.500	-14.069
-1.000	-1.729	40.000	40.265	104.500	-10.000	-11.249
0.0	-0.870	0.0	0.182	37.150	-7.500	-7.720
0.0	-0.773	0.0	0.240	70.250	-9.500	-10.155
0.0	-0.684	0.0	0.292	104.500	-11.000	-12.372
0.0	-0.861	10.000	10.187	37.150	-7.750	-7.943
0.0	-0.794	10.000	10.227	70.250	-9.000	-9.622
0.0	-0.776	10.000	10.238	104.500	-8.750	-10.076
0.0	-0.932	20.000	20.205	37.150	-8.500	-8.670
0.0	-0.765	20.000	20.244	70.250	-9.750	-10.349
0.0	-0.807	20.000	20.219	104.500	-8.000	-9.291
0.0	-0.904	30.000	30.162	37.150	-6.750	-6.877
0.0	-0.937	30.000	30.160	70.250	-6.250	-6.793
0.0	-0.989	30.000	30.112	104.500	-3.500	-4.728
0.0	-0.885	40.000	40.174	37.150	-7.250	-7.352
0.0	-0.948	40.000	40.136	70.250	-5.250	-5.756
0.0	-1.091	40.000	40.051	104.500	-1.000	-2.180
1.000	-0.131	0.0	0.028	37.150	-1.000	-1.170
1.000	-0.105	0.0	0.043	70.250	-1.250	-1.842
1.000	-0.086	0.0	0.054	104.500	-1.000	-2.296
1.000	-0.132	10.000	10.027	37.150	-1.000	-1.141
1.000	-0.136	10.000	10.025	70.250	-0.500	-1.057
1.000	-0.178	10.000	10.000	104.500	1.250	0.000
1.000	-0.053	20.000	20.074	37.150	-3.000	-3.128
1.000	-0.087	20.000	20.054	70.250	-1.750	-2.288
1.000	-0.159	20.000	20.011	104.500	0.750	-0.475
1.000	-0.125	30.000	30.032	37.150	-1.250	-1.335
1.000	-0.259	30.000	29.952	70.250	2.500	2.024
1.000	-0.371	30.000	29.896	104.500	6.000	4.844
1.000	-0.096	40.000	40.049	37.150	-2.000	-2.062
1.000	-0.270	40.000	39.946	70.250	2.750	2.305
1.000	-0.453	40.000	39.837	104.500	8.000	6.899
2.000	0.627	0.0	-0.115	37.150	5.000	4.875
2.000	0.564	0.0	-0.153	70.250	7.000	6.471
2.000	0.522	0.0	-0.178	104.500	8.750	7.529
2.000	0.676	10.000	9.884	37.150	5.000	4.904
2.000	0.522	10.000	9.823	70.250	8.000	7.508
2.000	0.450	10.000	9.780	104.500	10.500	9.321
2.000	0.706	20.000	19.931	37.150	3.000	2.918
2.000	0.572	20.000	19.852	70.250	6.750	6.277
2.000	0.429	20.000	19.767	104.500	11.000	9.854
2.000	0.634	30.000	29.889	37.150	4.750	4.710
2.000	0.440	30.000	29.774	70.250	10.000	9.581
2.000	0.267	30.000	29.672	104.500	15.000	13.913
2.000	0.703	40.000	39.930	37.150	3.000	2.976
2.000	0.439	40.000	39.773	70.250	10.000	9.610

SCHWINN 24X1-1/4 RRF7E SPORTS TOURING (CARLISLE, JUNE '71, WESTRICK RIM)

MEASURED SLIP ANGLE	CORRECTED SLIP ANGLE	MEASURED INCLINATION ANGLE	CORRECTED INCLINATION ANGLE	NORMAL FORCE	MEASURED LATERAL FORCE	CORRECTED LATERAL FORCE
2.000	0.155	40.000	39.696	104.500	17.750	16.713
3.000	1.366	0.0	-0.270	37.150	11.500	11.425
3.000	1.167	0.0	-0.391	70.250	17.000	16.548
3.000	1.089	0.0	-0.433	104.500	19.500	18.361
3.000	1.315	10.000	9.790	37.150	12.750	12.713
3.000	1.100	10.000	9.573	70.250	19.500	18.088
3.000	0.968	10.000	9.495	104.500	22.500	21.412
3.000	1.394	20.000	19.747	37.150	10.750	10.727
3.000	1.149	20.000	19.602	70.250	17.250	16.857
3.000	0.987	20.000	19.506	104.500	22.000	20.938
3.000	1.343	30.000	29.716	37.150	12.000	12.016
3.000	1.058	30.000	29.548	70.250	19.500	19.153
3.000	0.784	30.000	29.386	104.500	27.000	26.005
3.000	1.422	40.000	39.763	37.150	10.000	10.029
3.000	1.037	40.000	39.535	70.250	20.000	19.686
3.000	0.723	40.000	39.350	104.500	28.500	27.545
4.000	1.880	0.0	-0.383	37.150	16.250	16.211
4.000	1.758	0.0	-0.557	70.250	24.000	23.601
4.000	1.758	0.0	-0.629	104.500	27.750	26.674
4.000	2.094	10.000	9.569	37.150	18.250	18.255
4.000	1.759	10.000	9.371	70.250	27.000	26.653
4.000	1.606	10.000	9.281	104.500	31.500	30.481
4.000	2.143	20.000	19.598	37.150	17.000	17.025
4.000	1.818	20.000	19.406	70.250	25.500	25.170
4.000	1.695	20.000	19.280	104.500	31.500	30.510
4.000	2.111	30.000	29.580	37.150	17.750	17.809
4.000	1.766	30.000	29.376	70.250	26.750	26.459
4.000	1.463	30.000	29.196	104.500	35.000	34.066
4.000	2.191	40.000	39.627	37.150	15.750	15.823
4.000	1.755	40.000	39.369	70.250	27.000	26.740
4.000	1.391	40.000	39.148	104.500	37.000	36.110
6.000	3.874	0.0	-0.561	37.150	23.750	23.768
6.000	3.378	0.0	-0.854	70.250	36.500	36.196
6.000	3.125	0.0	-1.004	104.500	43.500	42.544
6.000	3.802	10.000	9.397	37.150	25.500	25.561
6.000	3.236	10.000	9.062	70.250	40.000	39.752
6.000	2.942	10.000	8.898	104.500	48.000	47.107
6.000	3.901	20.000	19.456	37.150	23.000	23.071
6.000	3.275	20.000	19.085	70.250	39.000	38.773
6.000	2.891	20.000	18.858	104.500	49.250	48.395
6.000	3.820	30.000	29.407	37.150	25.000	25.115
6.000	3.213	30.000	29.049	70.250	40.500	40.314
6.000	2.719	30.000	28.756	104.500	53.500	52.707
6.000	3.819	40.000	39.407	37.150	25.000	25.144
6.000	3.172	40.000	39.024	70.250	41.500	41.350
6.000	2.678	40.000	38.732	104.500	54.500	53.743
8.000	5.743	0.0	-0.638	37.150	27.000	27.043
8.000	4.996	0.0	-1.080	70.250	46.000	45.769
8.000	4.622	0.0	-1.301	104.500	56.000	55.139
8.000	5.852	10.000	9.426	37.150	24.250	24.301
8.000	4.844	10.000	8.830	70.250	49.750	49.576
8.000	4.380	10.000	8.555	104.500	62.000	61.214
8.000	5.861	20.000	19.432	37.150	24.000	24.078
8.000	4.772	20.000	19.788	70.250	51.500	51.369
8.000	4.278	20.000	18.495	104.500	64.500	63.762
8.000	5.679	30.000	29.374	37.150	29.500	28.641
8.000	4.771	30.000	28.737	70.250	51.500	51.398
8.000	4.136	30.000	28.411	104.500	68.000	67.317
8.000	5.799	40.000	39.395	37.150	25.500	25.648
8.000	4.830	40.000	33.827	70.250	50.000	49.915
8.000	4.195	40.000	38.446	104.500	66.500	65.835
10.000	7.703	0.0	-0.667	37.150	28.000	28.051
10.000	6.835	0.0	-1.175	70.250	50.000	49.799
10.000	6.300	0.0	-1.492	104.500	64.000	63.200
10.000	7.782	10.000	9.385	37.150	26.000	26.064
10.000	6.573	10.000	8.669	70.250	56.500	56.378
10.000	5.897	10.000	8.270	104.500	74.000	73.305
10.000	7.861	20.000	19.432	37.150	24.000	24.078
10.000	6.591	20.000	18.681	70.250	56.000	55.903
10.000	5.836	20.000	18.234	104.500	75.500	74.846
10.000	7.699	30.000	29.336	37.150	28.000	28.138
10.000	6.590	30.000	28.680	70.250	56.000	55.932
10.000	5.694	30.000	28.150	104.500	79.000	78.421
10.000	7.839	40.000	39.418	37.150	24.500	24.640
10.000	6.750	40.000	38.774	70.250	52.000	51.930
10.000	6.175	40.000	38.434	104.500	67.000	66.339

SCHWINN STRAIGHT SIDE TOURING

SLIP ANGLE BIAS = 0.752

MEASURED SLIP ANGLE	CORRECTED SLIP ANGLE	MEASURED INCLINATION ANGLE	CORRECTED INCLINATION ANGLE	NORMAL FORCE	MEASURED LATERAL FORCE	CORRECTED LATERAL FORCE
-3.000	-2.931	0.0	0.435	37.150	-20.250	-20.567
-3.000	-2.382	0.0	0.819	70.250	-33.500	-34.338
-3.000	-2.173	0.0	0.934	104.500	-38.000	-39.578
-3.000	-2.490	10.000	10.746	37.150	-31.250	-31.622
-3.000	-2.094	10.000	10.822	70.250	-34.000	-34.813
-3.000	-2.924	10.000	10.981	104.500	-40.000	-41.564
-3.000	-2.505	20.000	20.490	37.150	-20.500	-20.761
-3.000	-2.256	20.000	20.739	70.250	-30.500	-31.257
-3.000	-2.995	20.000	20.985	104.500	-36.000	-37.505
-3.000	-2.647	30.000	30.448	37.150	-18.750	-18.969
-3.000	-2.458	30.000	30.654	70.250	-27.000	-27.701
-3.000	-3.087	30.000	30.766	104.500	-31.000	-32.438
-3.000	-2.809	40.000	40.393	37.150	-16.500	-16.673
-3.000	-2.781	40.000	40.558	70.250	-23.000	-23.647
-2.000	-2.042	0.0	0.420	104.500	-23.000	-24.348
-2.000	-1.724	0.0	0.678	37.150	-17.500	-17.796
-2.000	-1.555	0.0	0.708	70.250	-25.000	-25.773
-2.000	-2.023	0.0	0.708	104.500	-28.500	-30.006
-2.000	-1.715	10.000	10.431	37.150	-18.000	-18.271
-2.000	-1.576	10.000	10.614	70.250	-25.250	-25.996
-2.000	-2.054	10.000	10.696	104.500	-28.000	-29.473
-2.000	-1.766	20.000	20.413	37.150	-17.250	-17.486
-2.000	-1.658	20.000	20.583	70.250	-24.000	-24.707
-2.000	-2.146	20.000	20.647	104.500	-26.000	-27.429
-2.000	-1.908	30.000	30.358	37.150	-15.000	-15.190
-2.000	-1.799	30.000	30.499	70.250	-20.500	-21.152
-2.000	-2.268	30.000	30.563	104.500	-22.500	-23.873
-2.000	-2.130	40.000	40.286	37.150	-12.000	-12.139
-2.000	-2.130	40.000	40.368	70.250	-15.000	-15.581
-2.000	-2.183	40.000	40.337	104.500	-13.000	-14.272
-1.000	-1.253	0.0	0.295	37.150	-12.250	-12.506
-1.000	-1.065	0.0	0.406	70.250	-16.500	-17.208
-1.000	-0.997	0.0	0.447	104.500	-17.500	-18.922
-1.000	-1.214	10.000	10.318	37.150	-13.250	-13.485
-1.000	-1.046	10.000	10.417	70.250	-17.000	-17.683
-1.000	-0.998	10.000	10.446	104.500	-17.500	-18.893
-1.000	-1.195	20.000	20.335	37.150	-14.000	-14.212
-1.000	-1.071	20.000	20.434	70.250	-17.750	-18.410
-1.000	-0.979	20.000	20.457	104.500	-18.000	-19.368
-1.000	-1.307	30.000	30.263	37.150	-11.000	-11.160
-1.000	-1.169	30.000	30.345	70.250	-14.000	-14.602
-1.000	-1.141	30.000	30.361	104.500	-14.000	-15.308
-1.000	-1.408	40.000	40.203	37.150	-8.500	-8.612
-1.000	-1.372	40.000	40.225	70.250	-9.000	-9.535
-1.000	-1.484	40.000	40.158	104.500	-5.500	-6.714
0.0	-0.504	0.0	0.147	37.150	-6.000	-6.209
0.0	-0.417	0.0	0.198	70.250	-7.500	-7.750
0.0	-0.399	0.0	0.209	104.500	-7.500	-8.845
0.0	-0.455	10.000	10.176	37.150	-7.250	-7.439
0.0	-0.408	10.000	10.203	70.250	-8.000	-8.614
0.0	-0.470	10.000	10.196	104.500	-7.000	-8.313
0.0	-0.366	20.000	20.228	37.150	-9.500	-9.677
0.0	-0.329	20.000	20.250	70.250	-10.000	-10.601
0.0	-0.381	20.000	20.219	104.500	-8.000	-9.291
0.0	-0.630	40.000	40.072	37.150	-3.000	-3.070
0.0	-0.683	40.000	40.041	70.250	-1.250	-1.726
0.0	-0.721	40.000	40.018	104.500	0.400	-0.769
1.000	0.184	0.0	-0.038	37.150	1.750	1.601
1.000	0.161	0.0	-0.052	70.250	2.750	2.189
1.000	0.159	0.0	-0.053	104.500	3.500	2.239
1.000	0.223	10.000	9.985	37.150	0.750	0.622
1.000	0.150	10.000	9.948	70.250	2.750	2.218
1.000	0.097	10.000	9.911	104.500	5.000	3.779
1.000	0.373	20.000	20.074	37.150	-3.000	-3.128
1.000	0.329	20.000	20.049	70.250	-1.500	-2.036
1.000	0.217	20.000	19.981	104.500	2.000	0.785
1.000	0.201	30.000	30.026	37.150	-1.000	-1.084
1.000	0.238	30.000	29.994	70.250	0.750	0.260
1.000	0.095	30.000	29.909	104.500	5.000	3.837
1.000	0.149	40.000	39.942	37.150	2.500	2.472
1.000	-0.055	40.000	39.871	70.250	8.000	7.595
1.000	-0.288	40.000	39.633	104.500	14.500	13.438
2.000	0.893	0.0	-0.210	37.150	9.000	8.906
2.000	0.769	0.0	-0.284	70.250	12.500	12.013
2.000	0.706	0.0	-0.320	104.500	14.750	13.574
2.000	0.932	10.000	9.913	37.150	9.000	7.927
2.000	0.763	10.000	9.716	70.250	12.500	12.042
2.000	0.675	10.000	9.661	104.500	15.500	14.359
2.000	1.091	20.000	19.907	37.150	4.000	3.926
2.000	0.947	20.000	19.822	70.250	8.000	7.537
2.000	0.815	20.000	19.744	104.500	12.000	10.861
2.000	1.070	30.000	29.895	37.150	4.500	4.458
2.000	0.886	30.000	29.786	70.250	9.500	9.077
2.000	0.693	30.000	29.672	104.500	15.000	13.913
2.000	0.968	40.000	39.815	37.150	7.000	7.006
2.000	0.684	40.000	39.666	70.250	14.500	14.144
2.000	0.370	40.000	39.481	104.500	23.000	22.003
3.000	1.591	0.0	-0.389	37.150	16.500	16.463
3.000	1.377	0.0	-0.515	70.250	22.250	21.838

SCHWINN STRAIGHT SIDE TOURING

MEASURED SLIP ANGLE	CORRECTED SLIP ANGLE	MEASURED INCLINATION ANGLE	CORRECTED INCLINATION ANGLE	NORMAL FORCE	MEASURED LATERAL FORCE	CORRECTED LATERAL FORCE
3.000	1.254	0.0	-0.598	104.500	26.000	24.910
3.000	1.610	10.000	9.673	37.150	16.000	15.988
3.000	1.335	10.000	9.460	70.250	23.250	22.874
3.000	1.173	10.000	9.364	104.500	28.000	26.954
3.000	1.730	20.000	19.693	37.150	13.000	12.894
3.000	1.485	20.000	19.549	70.250	19.500	19.125
3.000	1.292	20.000	19.435	104.500	25.000	23.960
3.000	1.769	30.000	29.716	37.150	17.000	17.016
3.000	1.504	30.000	29.560	70.250	19.000	18.650
3.000	1.251	30.000	29.410	104.500	24.000	24.097
3.000	1.687	40.000	39.669	37.150	14.000	14.060
3.000	1.342	40.000	39.464	70.250	21.000	22.709
3.000	0.988	40.000	39.255	104.500	37.500	31.576
4.000	2.450	0.0	-0.472	37.150	20.000	19.990
4.000	2.105	0.0	-0.676	70.250	29.000	28.639
4.000	1.701	0.0	-0.915	104.500	30.750	30.765
4.000	2.449	10.000	9.529	37.150	27.000	26.019
4.000	1.984	10.000	9.252	70.250	37.000	31.691
4.000	1.730	10.000	9.102	104.500	39.000	38.038
4.000	2.539	20.000	19.589	37.150	17.750	17.781
4.000	2.123	20.000	19.335	70.250	24.500	24.193
4.000	1.880	20.000	19.191	104.500	35.250	34.299
4.000	2.558	30.000	29.592	37.150	17.250	17.306
4.000	2.162	30.000	29.358	70.250	27.500	27.214
4.000	1.828	30.000	29.160	104.500	36.500	35.577
4.000	2.516	40.000	32.567	37.150	18.250	18.342
4.000	2.101	40.000	32.321	70.250	20.000	20.755
4.000	1.646	40.000	32.053	104.500	41.000	40.140
4.000	4.370	0.0	-0.519	37.150	27.000	22.005
4.000	3.603	0.0	-0.973	70.250	41.500	41.234
4.000	3.088	0.0	-1.278	104.500	55.000	54.131
4.000	4.329	10.000	9.656	37.150	23.000	23.042
4.000	3.561	10.000	9.002	70.250	47.500	47.271
4.000	3.047	10.000	8.598	104.500	56.000	55.168
4.000	4.398	20.000	19.491	37.150	21.500	21.659
4.000	3.580	20.000	19.014	70.250	47.000	41.796
4.000	3.086	20.000	18.721	104.500	55.000	54.189
4.000	4.246	30.000	29.407	37.150	25.000	25.115
4.000	3.459	30.000	28.942	70.250	45.000	44.848
4.000	2.964	30.000	28.649	104.500	58.000	57.241
4.000	4.325	40.000	39.454	37.150	23.000	23.128
4.000	3.578	40.000	39.012	70.250	47.000	41.854
4.000	3.093	40.000	38.672	104.500	57.000	56.262
8.000	6.209	0.0	-0.614	37.150	26.000	26.036
8.000	5.402	0.0	-1.092	70.250	46.500	46.273
8.000	4.626	0.0	-1.551	104.500	66.500	65.719
8.000	6.369	10.000	9.480	37.150	22.000	22.034
8.000	5.421	10.000	8.919	70.250	46.000	45.798
8.000	4.665	10.000	8.472	104.500	65.500	64.740
8.000	6.287	20.000	19.432	37.150	24.000	24.078
8.000	5.259	20.000	18.823	70.250	50.000	49.857
8.000	4.382	20.000	18.305	104.500	77.500	71.823
8.000	6.306	30.000	29.443	37.150	23.500	23.603
8.000	5.197	30.000	28.787	70.250	51.500	51.399
8.000	4.301	30.000	28.257	104.500	74.500	73.867
8.000	6.124	40.000	39.335	37.150	28.000	28.167
8.000	5.116	40.000	38.739	70.250	53.500	53.442
8.000	4.259	40.000	38.232	104.500	75.500	74.904
10.000	8.290	0.0	-0.567	37.150	24.000	24.020
10.000	7.281	0.0	-1.163	70.250	49.500	49.295
10.000	6.445	0.0	-1.658	104.500	71.000	70.253
10.000	8.369	10.000	9.440	37.150	22.000	22.034
10.000	7.260	10.000	8.924	70.250	50.000	49.828
10.000	6.162	10.000	8.175	104.500	78.000	77.336
10.000	8.125	30.000	29.336	37.150	28.000	28.138
10.000	6.936	30.000	28.632	70.250	58.000	57.947
10.000	5.999	30.000	28.078	104.500	82.000	81.424
10.000	8.064	40.000	29.300	37.150	29.500	29.478

SCHWINN 26X1-3/8 STRAIGHT SIDE SPORTS TOURING (GOODYEAR,3 QTR,71,WESTPI

SLIP ANGLE BIAS = 1.147

MEASURED SLIP ANGLE	CORRECTED SLIP ANGLE	MEASURED INCLINATION ANGLE	CORRECTED INCLINATION ANGLE	NORMAL FORCE	MEASURED LATERAL FORCE	CORRECTED LATERAL FORCE
-3.000	-3.125	0.0	0.504	37.150	-25.250	-25.605
-3.000	-2.606	0.0	0.911	70.250	-37.750	-38.670
-3.000	-2.377	0.0	1.047	104.500	-42.750	-44.364
-3.000	-3.116	10.000	10.610	37.150	-25.500	-25.828
-3.000	-2.637	10.000	10.893	70.250	-37.000	-37.835
-3.000	-2.468	10.000	10.993	104.500	-40.500	-42.068
-3.000	-3.138	20.000	20.597	37.150	-25.000	-25.296
-3.000	-2.719	20.000	20.845	70.250	-35.000	-35.791
-3.000	-2.570	20.000	20.933	104.500	-38.000	-39.520
-3.000	-3.219	30.000	30.549	37.150	-23.000	-23.251
-3.000	-2.871	30.000	30.755	70.250	-31.250	-31.984
-3.000	-2.722	30.000	30.843	104.500	-34.250	-35.713
-3.000	-3.190	40.000	40.572	37.150	-24.000	-24.230
-3.000	-2.842	40.000	40.772	70.250	-32.000	-32.710
-3.000	-2.874	40.000	40.753	104.500	-30.500	-31.905
-2.000	-2.286	0.0	0.509	37.150	-21.250	-21.575
-2.000	-1.998	0.0	0.630	70.250	-28.000	-28.796
-2.000	-1.329	0.0	0.779	104.500	-31.500	-33.028
-2.000	-2.317	10.000	10.421	37.150	-20.500	-20.790
-2.000	-1.979	10.000	10.631	70.250	-28.500	-29.271
-2.000	-1.891	10.000	10.743	104.500	-30.000	-31.488
-2.000	-2.299	20.000	20.502	37.150	-21.000	-21.265
-2.000	-2.031	20.000	20.660	70.250	-27.250	-27.982
-2.000	-1.962	20.000	20.701	104.500	-28.250	-29.676
-2.000	-2.430	30.000	30.424	37.150	-17.750	-17.961
-2.000	-2.162	30.000	30.582	70.250	-24.000	-24.678
-2.000	-2.124	30.000	30.605	104.500	-24.250	-25.636
-2.000	-2.281	40.000	40.453	37.150	-19.000	-19.192
-2.000	-2.194	40.000	40.566	70.250	-23.250	-23.894
-2.000	-2.286	40.000	40.539	104.500	-20.250	-21.577
-1.000	-1.497	0.0	0.384	37.150	-16.000	-16.285
-1.000	-1.320	0.0	0.489	70.250	-20.000	-20.745
-1.000	-1.211	0.0	0.554	104.500	-22.000	-23.456
-1.000	-1.618	10.000	10.372	37.150	-15.500	-15.752
-1.000	-1.361	10.000	10.465	70.250	-19.000	-19.698
-1.000	-1.313	10.000	10.493	104.500	-19.500	-20.908
-1.000	-1.459	20.000	20.437	37.150	-17.000	-17.235
-1.000	-1.312	20.000	20.434	70.250	-20.250	-20.929
-1.000	-1.304	20.000	20.439	104.500	-19.750	-21.131
-1.000	-1.691	30.000	30.329	37.150	-13.750	-13.931
-1.000	-1.464	30.000	30.404	70.250	-16.500	-17.121
-1.000	-1.496	30.000	30.385	104.500	-15.000	-16.316
-1.000	-1.642	40.000	40.358	37.150	-15.000	-15.161
-1.000	-1.495	40.000	40.336	70.250	-15.750	-16.336
-1.000	-1.644	40.000	40.295	104.500	-11.250	-12.508
0.0	-0.779	0.0	0.218	37.150	-7.000	-9.231
0.0	-0.671	0.0	0.291	70.250	-11.250	-11.918
0.0	-0.633	0.0	0.304	104.500	-11.500	-12.876
0.0	-0.770	10.000	10.223	37.150	-9.250	-9.454
0.0	-0.703	10.000	10.261	70.250	-10.500	-11.133
0.0	-0.715	10.000	10.256	104.500	-9.500	-10.832
0.0	-0.701	20.000	20.164	37.150	-11.000	-11.189
0.0	-0.654	20.000	20.292	70.250	-11.750	-12.364
0.0	-0.696	20.000	20.267	104.500	-10.000	-11.307
0.0	-0.812	30.000	30.198	37.150	-8.250	-8.399
0.0	-0.806	30.000	30.202	70.250	-8.000	-8.556
0.0	-0.878	30.000	30.159	104.500	-5.500	-6.743
0.0	-0.813	40.000	40.197	37.150	-8.250	-8.360
0.0	-0.837	40.000	40.183	70.250	-7.250	-7.772
0.0	-1.050	40.000	40.057	104.500	-1.250	-2.432
1.000	-0.100	0.0	0.028	37.150	-1.000	-1.170
1.000	-0.063	0.0	0.049	70.250	-1.500	-2.094
1.000	-0.086	0.0	0.036	104.500	-0.250	-1.540
1.000	-0.101	10.000	10.027	37.150	-1.000	-1.141
1.000	-0.115	10.000	10.019	70.250	-0.250	-0.805
1.000	-0.157	10.000	9.994	104.500	1.500	0.252
1.000	0.018	20.000	20.098	37.150	-4.000	-4.135
1.000	-0.036	20.000	20.066	70.250	-2.250	-2.791
1.000	-0.138	20.000	20.005	104.500	1.000	-0.223
1.000	-0.064	30.000	30.069	37.150	-2.000	-2.091
1.000	-0.127	30.000	30.012	70.250	0.0	-0.495
1.000	-0.280	30.000	29.971	104.500	4.500	3.333
1.000	-0.075	40.000	40.043	37.150	-1.750	-1.810
1.000	-0.109	40.000	39.969	70.250	1.750	1.297
1.000	-0.462	40.000	39.814	104.500	9.000	7.896
2.000	0.598	0.0	-0.151	37.150	6.500	6.387
2.000	0.655	0.0	-0.177	70.250	8.000	7.479
2.000	0.512	0.0	-0.201	104.500	8.000	8.536
2.000	0.617	10.000	9.860	37.150	6.000	5.912
2.000	0.513	10.000	9.739	70.250	9.000	8.515
2.000	0.421	10.000	9.744	104.500	12.000	10.832
2.000	0.777	20.000	19.955	37.150	2.000	1.910
2.000	0.623	20.000	19.864	70.250	6.250	5.773
2.000	0.470	20.000	19.773	104.500	10.750	9.692
2.000	0.675	30.000	29.895	37.150	4.500	4.458
2.000	0.511	30.000	29.738	70.250	9.000	8.573
2.000	0.308	30.000	29.678	104.500	14.750	13.661
2.000	0.694	40.000	39.976	37.150	4.000	3.984
2.000	0.439	40.000	39.755	70.250	10.750	10.366

SCHWINN 26X1-3/8 STRAIGHT SIDE SPORTS TOURING (GOODYEAR, 3 QTR, 171, WESTRI)

MEASURED SLIP ANGLE	CORRECTED SLIP ANGLE	MEASURED INCLINATION ANGLE	CORRECTED INCLINATION ANGLE	NORMAL FORCE	MEASURED LATERAL FORCE	CORRECTED LATERAL FORCE
2.000	0.146	40.000	39.587	104.500	18.750	17.721
2.000	1.277	0.0	-0.341	37.150	14.500	14.448
2.000	1.112	0.0	-0.438	70.250	19.000	18.563
2.000	1.040	0.0	-0.481	104.500	21.500	20.376
2.000	1.255	10.000	9.546	37.150	15.000	14.981
2.000	1.031	10.000	9.514	70.250	21.000	20.607
2.000	0.918	10.000	9.447	104.500	24.500	23.428
2.000	1.345	20.000	19.699	37.150	12.750	12.742
2.000	1.150	20.000	19.584	70.250	18.000	17.613
2.000	0.977	20.000	19.482	104.500	23.000	21.945
2.000	1.374	30.000	29.715	37.150	17.000	17.016
2.000	1.079	30.000	29.567	70.250	19.750	19.405
2.000	0.815	30.000	29.386	104.500	27.000	26.005
2.000	1.423	40.000	39.745	37.150	10.750	10.785
2.000	1.088	40.000	39.547	70.250	19.500	19.182
2.000	0.744	40.000	39.344	104.500	28.750	27.797
4.000	2.015	0.0	-0.476	37.150	21.000	20.997
4.000	1.710	0.0	-0.676	70.250	29.000	28.639
4.000	1.578	0.0	-0.754	104.500	33.000	31.964
4.000	2.024	10.000	9.510	37.150	20.750	20.774
4.000	1.699	10.000	9.317	70.250	29.500	29.172
4.000	1.506	10.000	9.203	104.500	34.750	33.756
4.000	2.063	20.000	19.533	37.150	19.750	19.796
4.000	1.758	20.000	19.352	70.250	27.750	27.437
4.000	1.555	20.000	19.232	104.500	33.500	32.425
4.000	2.002	30.000	29.553	37.150	19.000	19.069
4.000	1.717	30.000	29.328	70.250	28.750	28.474
4.000	1.433	30.000	29.160	104.500	36.500	35.577
4.000	2.171	40.000	39.597	37.150	17.000	17.083
4.000	1.786	40.000	39.369	70.250	27.000	26.740
4.000	1.377	40.000	39.174	104.500	38.000	37.118
6.000	3.734	0.0	-0.667	37.150	28.000	28.051
6.000	3.127	0.0	-1.021	70.250	43.500	43.250
6.000	2.894	0.0	-1.159	104.500	50.000	49.093
6.000	3.006	10.000	8.907	37.150	46.500	46.302
6.000	2.712	10.000	8.734	70.250	54.500	53.657
6.000	3.085	20.000	18.954	37.150	44.500	44.315
6.000	2.731	20.000	18.745	70.250	54.000	53.182
6.000	2.730	30.000	29.336	37.150	28.000	28.138
6.000	3.003	30.000	29.906	70.250	46.500	46.359
6.000	2.589	30.000	28.661	104.500	57.500	56.737
6.000	3.043	30.000	28.930	37.150	45.500	45.352
6.000	2.629	30.000	28.645	70.250	56.500	55.730
6.000	3.170	40.000	39.418	37.150	24.500	24.640
6.000	3.163	40.000	39.000	70.250	42.500	42.358
6.000	2.698	40.000	38.677	104.500	57.000	56.262
8.000	5.613	0.0	-0.733	37.150	31.000	31.074
8.000	4.605	0.0	-1.330	70.250	56.500	56.349
8.000	4.110	0.0	-1.622	104.500	69.500	68.742
8.000	5.833	10.000	9.397	37.150	25.500	25.561
8.000	4.583	10.000	8.658	70.250	57.000	56.882
8.000	4.089	10.000	8.365	104.500	70.000	69.275
8.000	4.582	20.000	18.657	37.150	57.000	56.911
8.000	4.068	20.000	18.353	70.250	70.500	69.808
8.000	4.541	30.000	29.632	37.150	58.000	57.947
8.000	3.825	30.000	28.209	70.250	76.500	75.882
8.000	5.629	40.000	39.276	104.500	80.500	79.882
8.000	4.660	40.000	38.703	37.150	30.500	30.686
8.000	3.844	40.000	38.220	70.250	55.000	54.953
10.000	7.613	0.0	-0.733	104.500	76.000	75.407
10.000	6.363	0.0	-1.473	37.150	31.000	31.074
10.000	5.628	0.0	-1.908	70.250	62.500	62.395
10.000	7.893	0.0	-2.432	104.500	81.500	80.834
10.000	7.893	10.000	9.432	37.150	24.000	24.049
10.000	6.483	10.000	8.598	70.250	59.500	59.401
10.000	5.647	10.000	8.134	104.500	81.000	80.359
10.000	7.832	20.000	19.396	37.150	25.500	25.590
10.000	5.585	20.000	18.067	70.250	82.500	81.899
10.000	5.443	30.000	27.983	104.500	86.000	85.455
10.000	7.669	40.000	39.300	37.150	29.500	29.678

SCHWINN 27X1-1/4 PUFF ROAD RACER (CARLISLE, NEW COMPOUND, ENDRICK RIM)

SLIP ANGLE BIAS = 1.548

MEASURED SLIP ANGLE	CORRECTED SLIP ANGLE	MEASURED INCLINATION ANGLE	CORRECTED INCLINATION ANGLE	NORMAL FORCE	MEASURED LATERAL FORCE	CORRECTED LATERAL FORCE
-3.000	-3.737	0.0	0.479	37.150	-20.000	-20.315
-3.000	-3.248	0.0	0.769	70.250	-31.750	-32.574
-3.000	-2.969	0.0	0.934	104.500	-39.000	-39.578
-3.000	-3.779	10.000	10.455	37.150	-19.000	-19.279
-3.000	-3.290	10.000	13.744	70.250	-30.750	-31.538
-3.000	-2.990	10.000	10.971	104.500	-37.250	-39.045
-3.000	-3.730	20.000	20.484	37.150	-20.250	-20.509
-3.000	-3.180	20.000	20.809	70.250	-33.500	-34.280
-3.000	-2.971	20.000	20.933	104.500	-39.000	-39.520
-3.000	-3.680	30.000	30.573	37.150	-24.000	-24.259
-3.000	-3.121	30.000	30.844	70.250	-35.000	-35.762
-3.000	-3.013	30.000	30.908	104.500	-37.000	-38.484
-3.000	-3.461	40.000	40.643	37.150	-27.000	-27.253
-3.000	-3.102	40.000	40.855	70.250	-35.500	-36.237
-3.000	-3.074	40.000	40.872	104.500	-35.500	-36.943
-2.000	-2.888	0.0	0.330	37.150	-16.250	-16.537
-2.000	-2.520	0.0	0.608	70.250	-25.000	-25.773
-2.000	-2.290	0.0	0.744	104.500	-30.000	-31.517
-2.000	-2.889	10.000	10.390	37.150	-16.250	-16.508
-2.000	-2.551	10.000	10.500	70.250	-24.250	-24.988
-2.000	-2.372	10.000	13.636	104.500	-28.000	-29.473
-2.000	-2.840	20.000	20.419	37.150	-17.500	-17.738
-2.000	-2.472	20.000	20.637	70.250	-26.250	-26.974
-2.000	-2.343	20.000	20.713	104.500	-28.750	-30.200
-2.000	-2.741	30.000	30.477	37.150	-20.000	-20.229
-2.000	-2.453	30.000	30.648	70.250	-26.750	-27.449
-2.000	-2.445	30.000	30.653	104.500	-26.250	-27.652
-2.000	-2.662	40.000	40.574	37.150	-22.000	-22.215
-2.000	-2.444	40.000	40.653	70.250	-27.000	-27.672
-2.000	-2.526	40.000	40.634	104.500	-24.250	-25.607
-1.000	-2.059	0.0	0.259	37.150	-12.000	-12.254
-1.000	-1.771	0.0	0.440	70.250	-18.750	-19.475
-1.000	-1.652	0.0	0.530	104.500	-21.000	-22.448
-1.000	-2.070	10.000	10.233	37.150	-11.750	-11.973
-1.000	-1.842	10.000	10.417	70.250	-17.000	-17.683
-1.000	-1.734	10.000	10.482	104.500	-19.000	-20.404
-1.000	-1.981	20.000	20.335	37.150	-14.000	-14.212
-1.000	-1.743	20.000	20.476	70.250	-19.500	-20.173
-1.000	-1.715	20.000	20.473	104.500	-19.500	-20.879
-1.000	-1.942	30.000	30.358	37.150	-15.000	-15.190
-1.000	-1.764	30.000	30.444	70.250	-19.000	-19.640
-1.000	-1.796	30.000	30.444	104.500	-17.500	-18.835
-1.000	-1.812	40.000	40.473	37.150	-17.750	-17.932
-1.000	-1.744	40.000	40.453	70.250	-19.000	-19.611
-1.000	-1.898	40.000	40.334	104.500	-15.000	-16.287
0.0	-1.190	0.0	0.212	37.150	-8.750	-8.980
0.0	-1.012	0.0	0.317	70.250	-12.750	-13.429
0.0	-0.944	0.0	0.357	104.500	-13.750	-15.143
0.0	-1.241	10.000	10.182	37.150	-7.500	-7.691
0.0	-1.124	10.000	10.251	70.250	-10.000	-10.629
0.0	-1.096	10.000	10.258	104.500	-10.000	-11.335
0.0	-1.172	20.000	20.222	37.150	-9.250	-9.425
0.0	-1.085	20.000	20.274	70.250	-11.000	-11.608
0.0	-1.097	20.000	20.257	104.500	-10.000	-11.307
0.0	-1.133	30.000	30.245	37.150	-10.250	-10.404
0.0	-1.116	30.000	30.255	70.250	-10.250	-10.823
0.0	-1.219	30.000	30.195	104.500	-7.000	-8.255
0.0	-1.064	40.000	40.246	37.150	-12.000	-12.139
0.0	-1.117	40.000	40.255	70.250	-10.250	-10.795
0.0	-1.300	40.000	40.147	104.500	-5.000	-6.210
1.000	-0.431	0.0	0.069	37.150	-2.750	-2.934
1.000	-0.364	0.0	0.109	70.250	-4.000	-4.613
1.000	-0.336	0.0	0.176	104.500	-4.000	-5.319
1.000	-0.432	10.000	10.089	37.150	-2.750	-2.905
1.000	-0.435	10.000	10.067	70.250	-2.750	-2.820
1.000	-0.458	10.000	10.053	104.500	-1.000	-2.267
1.000	-0.383	20.000	20.098	37.150	-4.000	-4.135
1.000	-0.366	20.000	20.197	70.250	-4.000	-4.555
1.000	-0.449	20.000	20.047	104.500	-0.750	-1.986
1.000	-0.384	30.000	30.097	37.150	-4.000	-4.106
1.000	-0.458	30.000	30.053	70.250	-1.750	-2.259
1.000	-0.601	30.000	29.969	104.500	2.500	1.318
1.000	-0.325	40.000	40.132	37.150	-5.500	-5.589
1.000	-0.489	40.000	40.035	70.250	-1.000	-1.474
1.000	-0.712	40.000	39.973	104.500	5.250	4.119
2.000	0.378	0.0	-0.044	37.150	2.000	1.852
2.000	0.345	0.0	-0.064	70.250	3.250	2.693
2.000	0.322	0.0	-0.077	104.500	4.500	3.246
2.000	0.337	10.000	2.032	37.150	3.000	2.889
2.000	0.243	10.000	2.875	70.250	5.750	5.241
2.000	0.140	10.000	3.816	104.500	9.000	7.809
2.000	0.406	20.000	19.973	37.150	1.250	1.155
2.000	0.272	20.000	19.993	70.250	5.000	4.514
2.000	0.139	20.000	19.815	104.500	9.000	7.838
2.000	0.344	30.000	29.736	37.150	2.750	2.695
2.000	0.190	30.000	29.945	70.250	7.000	6.558
2.000	0.007	30.000	29.737	104.500	12.250	11.142
2.000	0.373	40.000	39.954	37.150	2.000	1.968
2.000	0.129	40.000	39.909	70.250	4.500	8.099

SCHWINN 27X1-1/4 PUFF ROAD RACER (CARLISLE, NEW COMPOUND, ENDRICK RIM)

MEASURED SLIP ANGLE	CORRECTED SLIP ANGLE	MEASURED INCLINATION ANGLE	CORRECTED INCLINATION ANGLE	NORMAL FORCE	MEASURED LATERAL FORCE	CORRECTED LATERAL FORCE
2.000	-0.155	40.000	39.641	104.500	16.250	15.202
3.000	1.117	0.0	-0.198	37.150	8.500	8.402
3.000	0.953	0.0	-0.295	70.250	13.000	12.517
3.000	0.890	0.0	-0.332	104.500	15.250	14.078
3.000	1.055	10.000	9.765	37.150	10.000	9.942
3.000	0.871	10.000	9.554	70.250	15.000	14.561
3.000	0.718	13.000	9.566	104.500	19.500	18.390
3.000	1.114	20.000	19.909	37.150	8.500	8.460
3.000	0.910	20.000	19.679	70.250	14.000	13.583
3.000	0.707	20.000	19.559	104.500	19.750	18.670
3.000	1.053	30.000	29.764	37.150	10.000	10.000
3.000	0.768	30.000	29.596	70.250	17.500	17.138
3.000	0.535	30.000	29.459	104.500	24.000	22.982
3.000	1.032	40.000	39.751	37.150	10.500	10.533
3.000	0.707	40.000	39.559	70.250	19.000	18.679
3.000	0.373	40.000	39.362	104.500	28.000	27.041
4.000	1.916	0.0	-0.317	37.150	13.500	13.440
4.000	1.661	0.0	-0.468	70.250	20.250	19.822
4.000	1.518	0.0	-0.552	104.500	24.500	23.399
4.000	1.874	10.000	9.558	37.150	14.500	14.477
4.000	1.590	10.000	9.490	70.250	22.000	21.615
4.000	1.427	13.000	9.394	104.500	26.750	25.695
4.000	1.913	20.000	19.691	37.150	13.500	13.498
4.000	1.598	20.000	19.495	70.250	21.750	21.392
4.000	1.365	20.000	19.357	104.500	29.250	27.235
4.000	1.782	30.000	29.603	37.150	16.750	16.802
4.000	1.447	30.000	29.495	70.250	25.500	25.199
4.000	1.133	30.000	29.220	104.500	34.000	33.058
4.000	1.760	40.000	39.591	37.150	17.250	17.335
4.000	1.345	40.000	39.345	70.250	28.000	27.747
4.000	0.971	40.000	39.124	104.500	38.000	37.118
6.000	3.664	0.0	-0.466	37.150	19.750	19.738
6.000	3.209	0.0	-0.735	70.250	31.500	31.158
6.000	2.966	0.0	-0.879	104.500	38.250	37.254
6.000	3.633	10.000	9.516	37.150	20.500	20.623
6.000	3.077	10.000	9.187	70.250	34.750	34.462
6.000	2.763	10.000	9.001	104.500	43.250	42.321
6.000	3.672	20.000	19.539	37.150	19.500	19.544
6.000	3.096	20.000	19.192	70.250	34.500	34.239
6.000	2.672	20.000	18.947	104.500	45.500	44.617
6.000	3.490	30.000	29.431	37.150	24.000	24.107
6.000	2.783	30.000	29.013	70.250	42.000	41.825
6.000	2.329	30.000	28.744	104.500	54.000	53.211
6.000	3.308	40.000	39.323	37.150	28.500	28.670
6.000	2.671	40.000	39.071	70.250	46.000	45.885
6.000	2.147	40.000	38.637	104.500	58.500	57.774
8.000	5.554	0.0	-0.531	37.150	22.500	22.509
8.000	4.807	0.0	-0.973	70.250	41.500	41.234
8.000	4.393	0.0	-1.218	104.500	52.500	51.612
8.000	5.593	10.000	9.492	37.150	21.500	21.530
8.000	4.705	10.000	9.967	70.250	44.000	43.782
8.000	4.130	10.000	8.527	104.500	59.000	58.191
8.000	4.724	20.000	18.978	37.150	43.500	43.398
8.000	4.089	20.000	18.602	70.250	60.000	59.227
8.000	5.490	30.000	29.431	37.150	24.000	24.107
8.000	4.502	30.000	28.846	70.250	49.000	48.879
8.000	3.746	30.000	28.399	104.500	68.500	67.821
8.000	5.288	40.000	39.311	37.150	29.000	29.174
8.000	4.239	40.000	38.691	70.250	55.500	55.457
8.000	3.443	40.000	38.220	104.500	76.000	75.407
10.000	7.473	0.0	-0.579	37.150	24.500	24.524
10.000	6.505	0.0	-1.151	70.250	49.000	48.792
10.000	5.971	0.0	-1.468	104.500	63.000	62.192
10.000	7.573	10.000	9.480	37.150	22.000	22.034
10.000	6.464	10.000	8.824	70.250	50.000	49.828
10.000	5.809	10.000	8.436	104.500	67.000	66.252
10.000	5.727	20.000	18.188	37.150	69.000	68.296
10.000	6.421	30.000	28.799	70.250	51.000	50.894
10.000	5.505	30.000	28.257	104.500	74.500	73.867

SCHWINN 27X1-1/4 HP SPORTS TOURING - BIAS PLY (NATIONAL, ENDRICK RIM)

SLIP ANGLE BIAS = 1.030

MEASURED SLIP ANGLE	CORRECTED SLIP ANGLE	MEASURED INCLINATION ANGLE	CORRECTED INCLINATION ANGLE	NORMAL FORCE	MEASURED LATERAL FORCE	CORRECTED LATERAL FORCE
-3.000	-3.139	0.0	0.527	37.150	-22.000	-22.331
-3.000	-2.640	0.0	0.827	70.250	-36.000	-34.842
-3.000	-2.401	0.0	0.964	104.500	-39.250	-40.838
-3.000	-3.160	10.000	10.514	37.150	-21.500	-21.798
-3.000	-2.802	10.000	10.726	70.250	-30.000	-30.782
-3.000	-2.593	10.000	10.850	104.500	-34.500	-36.022
-3.000	-2.803	20.000	20.776	70.250	-30.000	-30.753
-3.000	-2.624	20.000	20.832	104.500	-33.750	-35.238
-3.000	-3.022	30.000	30.596	37.150	-25.000	-25.267
-3.000	-2.563	30.000	30.868	70.250	-36.000	-36.770
-3.000	-3.063	40.000	40.572	37.150	-24.000	-24.230
-3.000	-2.765	40.000	40.748	70.250	-31.000	-31.703
-3.000	-2.928	40.000	40.552	104.500	-26.250	-27.623
-2.000	-2.260	0.0	0.454	37.150	-19.000	-19.308
-2.000	-1.972	0.0	0.626	70.250	-25.750	-26.629
-2.000	-1.813	0.0	0.720	104.500	-29.000	-30.509
-2.000	-2.351	10.000	10.401	37.150	-16.750	-17.012
-2.000	-2.123	10.000	10.536	70.250	-22.000	-22.721
-2.000	-1.995	10.000	10.612	104.500	-24.500	-25.946
-2.000	-2.403	20.000	20.371	37.150	-15.500	-15.723
-2.000	-2.115	20.000	20.541	70.250	-22.250	-22.944
-2.000	-2.016	20.000	20.600	104.500	-24.000	-25.413
-2.000	-2.183	30.000	30.501	37.150	-21.000	-21.236
-2.000	-1.885	30.000	30.678	70.250	-28.000	-28.709
-2.000	-2.244	40.000	40.465	37.150	-19.500	-19.696
-2.000	-2.087	40.000	40.558	70.250	-23.000	-23.642
-2.000	-2.270	40.000	40.450	104.500	-17.750	-19.058
-1.000	-1.461	0.0	0.337	37.150	-14.000	-14.270
-1.000	-1.293	0.0	0.436	70.250	-17.750	-18.468
-1.000	-1.185	0.0	0.500	104.500	-19.750	-21.189
-1.000	-1.512	10.000	10.306	37.150	-12.750	-12.981
-1.000	-1.365	10.000	10.394	70.250	-16.000	-16.675
-1.000	-1.326	10.000	10.416	104.500	-16.250	-17.633
-1.000	-1.553	20.000	20.282	37.150	-11.750	-11.945
-1.000	-1.386	20.000	20.381	70.250	-15.500	-16.142
-1.000	-1.388	20.000	20.380	104.500	-14.750	-16.093
-1.000	-1.384	30.000	30.382	37.150	-16.000	-16.198
-1.000	-1.327	30.000	30.415	70.250	-17.000	-17.625
-1.000	-1.369	30.000	30.391	104.500	-15.250	-16.568
-1.000	-1.425	40.000	40.358	37.150	-15.000	-15.161
-1.000	-1.428	40.000	40.356	70.250	-14.500	-15.077
-1.000	-1.421	40.000	40.342	104.500	-9.000	-10.241
0.0	-0.732	0.0	0.176	37.150	-7.250	-7.468
0.0	-0.655	0.0	0.222	70.250	-8.750	-9.399
0.0	-0.597	0.0	0.256	104.500	-9.500	-10.861
0.0	-0.743	10.000	10.170	37.150	-7.000	-7.187
0.0	-0.696	10.000	10.197	70.250	-7.750	-8.362
0.0	-0.678	10.000	10.208	104.500	-7.500	-8.816
0.0	-0.714	20.000	20.197	37.150	-7.750	-7.914
0.0	-0.677	20.000	20.209	70.250	-8.250	-8.837
0.0	-0.750	20.000	20.166	104.500	-5.750	-7.024
0.0	-0.625	30.000	30.240	37.150	-10.000	-10.152
0.0	-0.648	30.000	30.226	70.250	-9.000	-9.564
0.0	-0.791	30.000	30.141	104.500	-4.750	-5.988
0.0	-0.646	40.000	40.227	37.150	-9.500	-9.619
0.0	-0.750	40.000	40.166	70.250	-6.500	-7.016
0.0	-1.003	40.000	40.016	104.500	0.500	-0.669
1.000	-0.034	0.0	-0.002	37.150	0.250	0.089
1.000	-0.017	0.0	0.008	70.250	0.250	-0.330
1.000	0.011	0.0	0.024	104.500	0.250	-1.036
1.000	-0.015	10.000	10.009	37.150	-0.250	-0.386
1.000	-0.038	10.000	9.995	70.250	0.750	0.203
1.000	-0.080	10.000	9.970	104.500	2.500	1.260
1.000	0.034	20.000	20.039	37.150	-1.500	-1.616
1.000	-0.039	20.000	19.995	70.250	0.750	0.231
1.000	-0.142	20.000	19.934	104.500	4.000	2.800
1.000	0.094	30.000	30.073	37.150	-3.000	-3.099
1.000	-0.010	30.000	30.012	70.250	0.0	-0.495
1.000	-0.223	30.000	29.885	104.500	6.000	4.844
1.000	0.052	40.000	40.049	37.150	-2.000	-2.062
1.000	-0.172	40.000	39.916	70.250	4.000	3.564
1.000	-0.466	40.000	39.742	104.500	12.000	10.919
2.000	0.695	0.0	-0.163	37.150	7.000	6.891
2.000	0.631	0.0	-0.200	70.250	9.000	8.487
2.000	0.619	0.0	-0.207	104.500	10.000	8.788
2.000	0.724	10.000	9.855	37.150	6.250	6.164
2.000	0.620	10.000	9.793	70.250	9.250	8.767
2.000	0.548	10.000	9.750	104.500	11.750	10.590
2.000	0.823	20.000	19.913	37.150	3.750	3.674
2.000	0.689	20.000	19.834	70.250	7.500	7.033
2.000	0.537	20.000	19.744	104.500	12.000	10.861
2.000	0.812	30.000	20.907	37.150	4.000	3.955
2.000	0.608	30.000	29.786	70.250	9.500	9.077
2.000	0.365	30.000	29.642	104.500	16.250	15.173
2.000	0.781	40.000	39.888	37.150	4.750	4.739
2.000	0.466	40.000	39.702	70.250	13.000	12.633
2.000	0.142	40.000	39.510	104.500	21.750	20.744
3.000	1.394	0.0	-0.341	37.150	14.500	14.448
3.000	1.249	0.0	-0.426	70.250	18.500	18.059

SCHWINN 27X1-1/4 HP SPORTS TOURING - 91AS PLY (NATIONAL, ENDRICK RIM)

MEASURED SLIP ANGLE	CORRECTED SLIP ANGLE	MEASURED INCLINATION ANGLE	CORRECTED INCLINATION ANGLE	NORMAL FORCE	MEASURED LATERAL FORCE	CORRECTED LATERAL FORCE
3.000	1.187	0.0	-0.463	104.500	20.750	19.620
3.000	1.453	10.000	9.594	37.150	13.000	12.965
3.000	1.258	10.000	9.579	70.250	18.250	17.836
3.000	1.136	10.000	9.597	104.500	27.000	20.909
3.000	1.492	20.000	19.717	37.150	12.000	11.987
3.000	1.247	20.000	19.572	70.250	18.500	18.117
3.000	1.084	20.000	19.476	104.500	23.250	22.197
3.000	1.420	30.000	29.675	37.150	13.750	13.779
3.000	1.156	30.000	29.518	70.250	20.750	20.413
3.000	0.912	30.000	29.374	104.500	27.500	26.508
3.000	1.409	40.000	39.668	37.150	14.000	14.060
3.000	1.034	40.000	39.446	70.250	23.750	23.465
3.000	0.690	40.000	39.243	104.500	33.000	32.079
4.000	2.203	0.0	-0.454	37.150	19.250	19.234
4.000	1.908	0.0	-0.628	70.250	27.000	26.674
4.000	1.795	0.0	-0.675	104.500	30.500	29.445
4.000	2.232	10.000	9.563	37.150	18.500	18.507
4.000	1.937	10.000	9.389	70.250	26.250	25.897
4.000	1.774	10.000	9.293	104.500	31.000	29.977
4.000	2.271	20.000	19.586	37.150	17.500	17.529
4.000	1.946	20.000	19.394	70.250	26.000	25.674
4.000	1.692	20.000	19.244	104.500	33.000	32.021
4.000	2.159	30.000	29.570	37.150	20.250	20.329
4.000	1.804	30.000	29.310	70.250	29.500	29.230
4.000	1.520	30.000	29.143	104.500	37.250	36.333
4.000	2.107	40.000	39.490	37.150	21.500	21.617
4.000	1.662	40.000	39.226	70.250	33.000	32.785
4.000	1.288	40.000	39.005	104.500	43.000	42.156
6.000	3.931	0.0	-0.614	37.150	26.000	26.036
6.000	3.345	0.0	-0.961	70.250	41.000	40.731
6.000	3.122	0.0	-1.093	104.500	47.250	46.322
6.000	3.091	0.0	-0.579	37.150	24.500	24.524
6.000	3.345	0.0	-0.937	70.250	40.000	39.723
6.000	3.152	0.0	-1.075	104.500	46.500	45.567
6.000	3.050	10.000	9.397	37.150	25.500	25.561
6.000	3.394	10.000	9.262	70.250	40.000	39.752
6.000	3.390	10.000	8.888	104.500	48.000	47.107
6.000	4.090	20.000	19.479	37.150	27.000	27.063
6.000	3.423	20.000	19.285	70.250	39.000	38.773
6.000	3.049	20.000	18.964	104.500	49.000	48.144
6.000	3.988	30.000	29.419	37.150	24.500	24.611
6.000	3.140	30.000	23.918	70.250	46.000	45.856
6.000	2.706	30.000	28.661	104.500	57.500	56.737
6.000	3.286	40.000	39.359	37.150	27.000	27.159
6.000	3.099	40.000	39.893	70.250	47.000	46.892
6.000	2.544	40.000	39.565	104.500	61.500	60.797
8.000	5.851	0.0	-0.662	37.150	28.000	28.051
8.000	4.983	0.0	-1.175	70.250	50.000	49.799
8.000	4.549	0.0	-1.432	104.500	61.500	60.681
8.000	4.962	10.000	9.912	37.150	50.500	50.332
8.000	4.447	10.000	8.508	104.500	64.000	63.229
8.000	6.110	20.000	19.491	37.150	21.500	21.559
8.000	5.061	20.000	19.871	70.250	48.000	47.842
8.000	4.446	20.000	19.507	104.500	64.000	63.258
8.000	6.089	30.000	29.479	37.150	27.000	27.092
8.000	4.899	30.000	29.775	70.250	52.000	51.901
8.000	4.063	30.000	28.291	104.500	73.500	72.859
8.000	5.206	40.000	37.371	37.150	26.500	26.655
8.000	3.841	40.000	39.149	104.500	70.000	78.430
10.000	6.903	0.0	-1.223	70.250	52.000	51.815
10.000	6.187	0.0	-1.646	104.500	70.500	69.750
10.000	6.921	10.000	9.729	37.150	54.000	53.859
10.000	6.105	10.000	9.326	104.500	77.500	71.794
10.000	8.009	20.000	19.432	37.150	24.000	24.078
10.000	6.981	20.000	19.823	70.250	50.000	49.857
10.000	6.044	20.000	19.269	104.500	74.000	73.334
10.000	7.806	40.000	39.311	37.150	29.000	29.174

SCHWINN 27X1-1/4 GREEZE SPORTS TOURING

SLIP ANGLE BIAS = 0.990

MEASURED SLIP ANGLE	CORRECTED SLIP ANGLE	MEASURED INCLINATION ANGLE	CORRECTED INCLINATION ANGLE	NORMAL FORCE	MEASURED LATERAL FORCE	CORRECTED LATERAL FORCE
-2.000	-2.262	20.000	20.430	36.400	-18.000	-18.236
-2.000	-2.424	30.000	30.335	36.400	-14.000	-14.176
-2.000	-2.426	40.000	40.334	36.400	-14.000	-14.147
-1.000	-1.463	20.000	20.311	36.400	-11.000	-11.198
-1.000	-1.535	30.000	30.239	36.400	-10.000	-10.146
-1.000	-1.627	40.000	40.215	36.400	-9.000	-9.109
-0.500	-1.001	0.0	0.249	36.400	-17.000	-17.248
-0.500	-1.083	10.000	10.241	36.400	-17.000	-17.274
-0.500	-1.104	20.000	20.228	36.400	-9.500	-9.671
-0.500	-1.166	30.000	30.142	36.400	-8.000	-8.130
-0.500	-1.167	40.000	40.191	36.400	-8.000	-8.102
0.0	-0.622	0.0	0.218	36.400	-9.000	-9.225
0.0	-0.683	10.000	10.141	36.400	-7.500	-7.635
0.0	-0.745	20.000	20.145	36.400	-6.000	-6.144
0.0	-0.796	30.000	30.121	36.400	-5.000	-5.108
0.0	-0.823	40.000	40.096	36.400	-4.000	-4.071
0.500	-0.333	0.0	0.111	36.400	-4.500	-4.691
0.500	-0.324	10.000	10.099	36.400	-4.000	-4.158
0.500	-0.325	20.000	20.097	36.400	-4.000	-4.129
0.500	-0.347	30.000	30.035	36.400	-3.500	-3.596
0.500	-0.489	40.000	40.001	36.400	0.0	-0.040
1.000	-0.004	0.0	-0.008	36.400	0.500	0.348
1.000	-0.025	10.000	9.979	36.400	1.000	0.880
1.000	0.014	20.000	20.012	36.400	0.0	-0.098
1.000	-0.038	30.000	29.947	36.400	2.500	2.450
1.000	-0.184	40.000	39.832	36.400	5.000	4.999
2.000	0.735	0.0	-0.163	36.400	7.000	6.897
2.000	0.734	10.000	9.837	36.400	7.000	6.926
2.000	0.732	20.000	19.836	36.400	7.000	6.955
2.000	0.571	30.000	29.740	36.400	11.000	11.014
2.000	0.610	40.000	39.753	36.400	13.000	10.236
3.000	1.333	0.0	-0.401	36.400	17.000	16.973
3.000	1.372	10.000	9.623	36.400	16.000	15.995
3.000	1.270	20.000	19.562	36.400	13.500	18.543
3.000	1.309	30.000	29.535	36.400	17.500	17.564
3.000	1.328	40.000	39.597	36.400	17.000	17.099
4.000	2.272	0.0	-0.436	36.400	18.500	18.485
4.000	2.131	10.000	9.480	36.400	22.000	22.040
4.000	2.129	20.000	19.479	36.400	22.000	22.069
4.000	2.148	30.000	29.470	36.400	21.500	21.595
4.000	2.208	40.000	39.525	36.400	20.000	20.112
6.000	3.931	0.0	-0.638	36.400	27.000	27.050
6.000	3.889	10.000	9.337	36.400	28.000	28.086
6.000	4.009	20.000	19.439	36.400	25.000	25.092
6.000	3.967	30.000	29.333	36.400	26.000	26.129
6.000	4.167	40.000	39.532	36.400	21.000	21.120
8.000	5.850	0.0	-0.685	36.400	29.000	29.065
8.000	5.843	10.000	9.313	36.400	29.000	29.094
8.000	6.389	20.000	19.455	36.400	24.000	23.977
8.000	5.967	30.000	29.383	36.400	26.000	26.129
8.000	6.047	40.000	39.430	36.400	24.000	24.143
10.000	8.088	30.000	29.455	36.400	23.000	23.106
10.000	8.087	40.000	39.454	36.400	23.000	23.135
-2.000	-1.962	20.000	20.638	73.400	-25.000	-25.768
-2.000	-2.244	30.000	30.441	73.400	-18.000	-18.686
-2.000	-2.447	40.000	40.321	73.400	-13.000	-13.619
-1.000	-1.304	20.000	20.406	73.400	-16.500	-17.203
-1.000	-1.506	30.000	30.286	73.400	-11.500	-12.136
-1.000	-1.628	40.000	40.214	73.400	-9.500	-9.985
-0.500	-0.841	0.0	0.384	73.400	-15.500	-16.254
-0.500	-0.943	10.000	10.323	73.400	-13.000	-13.706
-0.500	-0.985	20.000	20.229	73.400	-12.000	-12.669
-0.500	-1.146	30.000	30.233	73.400	-8.000	-8.610
-0.500	-1.308	40.000	40.137	73.400	-4.000	-4.550
0.0	-0.502	0.0	0.288	73.400	-11.500	-12.223
0.0	-0.664	10.000	10.193	73.400	-7.500	-8.164
0.0	-0.645	20.000	20.204	73.400	-3.000	-3.639
0.0	-0.727	30.000	30.156	73.400	-6.000	-6.594
0.0	-1.009	40.000	39.938	73.400	1.000	0.488
0.500	-0.223	0.0	0.158	73.400	-6.000	-6.681
0.500	-0.365	10.000	10.074	73.400	-2.500	-3.126
0.500	-0.266	20.000	20.133	73.400	-5.000	-5.616
0.500	-0.549	30.000	29.965	73.400	2.000	1.467
0.500	-0.751	40.000	39.846	73.400	7.000	6.534
1.000	-0.005	0.0	-0.009	73.400	1.000	0.372
1.000	-0.086	10.000	9.943	73.400	3.000	2.416
1.000	-0.047	20.000	19.966	73.400	2.000	1.438
1.000	-0.209	30.000	29.870	73.400	6.000	5.497
1.000	-0.412	40.000	39.751	73.400	11.000	10.564
2.000	0.674	0.0	-0.199	73.400	9.000	8.433
2.000	0.552	10.000	9.179	73.400	12.000	11.485
2.000	0.651	20.000	19.283	73.400	9.500	8.995
2.000	0.369	30.000	29.621	73.400	16.500	16.077
2.000	0.227	40.000	39.537	73.400	20.000	19.633
3.000	1.211	0.0	-0.472	73.400	20.500	20.021
3.000	1.089	10.000	9.455	73.400	23.500	23.073
3.000	1.108	20.000	19.467	73.400	23.000	22.538
3.000	0.926	30.000	29.359	73.400	27.500	27.141
3.000	0.825	40.000	39.299	73.400	30.000	29.700

SCHWINN 27X1-1/4 BREEZE SPORTS TOURING

MEASURED SLIP ANGLE	CORRECTED SLIP ANGLE	MEASURED INCLINATION ANGLE	CORRECTED INCLINATION ANGLE	NORMAL FORCE	MEASURED LATERAL FORCE	CORRECTED LATERAL FORCE
4.000		0.0	-0.639	73.400	27.500	27.074
4.000	1.930	10.000	9.213	73.400	33.500	33.149
4.000	1.687	20.000	19.181	73.400	35.000	34.689
4.000	1.554	30.000	29.145	73.400	36.500	36.230
4.000	1.543	40.000	39.132	73.400	37.000	36.763
6.000	3.337	0.0	-1.078	73.400	43.000	42.693
6.000	3.265	10.000	8.968	73.400	44.000	43.722
6.000	3.143	20.000	18.876	73.400	46.000	46.781
6.000	3.022	30.000	28.824	73.400	47.000	49.833
6.000	3.181	40.000	38.918	73.400	50.000	46.831
8.000	4.945	0.0	-1.722	73.400	52.000	51.761
8.000	4.863	10.000	8.730	73.400	54.000	53.805
8.000	4.782	20.000	18.632	73.400	54.000	55.850
8.000	4.901	30.000	28.753	73.400	53.000	52.856
8.000	4.980	40.000	38.729	73.400	51.000	50.869
10.000	6.821	0.0	-2.705	73.400	55.000	54.871
10.000	6.980	10.000	33.720	73.400	51.000	50.869
-2.000	-1.895	20.000	20.643	105.500	-26.000	-27.453
-2.000	-2.177	30.000	31.491	105.500	-19.000	-20.371
-2.000	-2.500	40.000	42.220	105.500	-11.000	-12.281
-1.000	-1.196	20.000	20.470	105.500	-18.500	-19.895
-1.000	-1.459	30.000	30.314	105.500	-12.000	-13.318
-1.000	-1.781	40.000	40.123	105.500	-4.000	-5.228
-0.500	-0.754	0.0	0.435	105.500	-17.000	-18.443
-0.500	-0.836	10.000	10.387	105.500	-15.000	-16.398
-0.500	-0.917	20.000	20.339	105.500	-13.000	-14.354
-0.500	-1.180	30.000	30.134	105.500	-6.500	-7.276
-0.500	-1.442	40.000	40.028	105.500	0.0	-1.197
0.0	-0.395	0.0	0.452	105.500	-13.500	-14.916
0.0	-0.457	10.000	10.222	105.500	-11.000	-12.358
0.0	-0.538	20.000	20.267	105.500	-10.000	-11.331
0.0	-0.700	30.000	30.172	105.500	-6.000	-7.272
0.0	-1.244	40.000	39.850	105.500	7.500	6.360
0.500	-0.156	0.0	0.197	105.500	-7.000	-8.166
0.500	-0.318	10.000	10.102	105.500	-3.000	-4.307
0.500	-0.400	20.000	20.053	105.500	-1.000	-2.263
0.500	-0.562	30.000	29.958	105.500	3.000	1.797
0.500	-1.005	40.000	39.695	105.500	14.000	17.910
1.000	0.002	0.0	-0.005	105.500	1.500	0.109
1.000	-0.059	10.000	9.959	105.500	3.000	1.739
1.000	-0.101	20.000	19.934	105.500	4.000	2.776
1.000	-0.464	30.000	29.720	105.500	13.000	11.873
1.000	-0.706	40.000	39.576	105.500	19.000	17.748
2.000	0.701	0.0	-0.193	105.500	9.000	7.756
2.000	0.539	10.000	9.721	105.500	13.000	11.915
2.000	0.417	20.000	19.649	105.500	16.000	15.867
2.000	0.074	30.000	29.446	105.500	26.500	23.461
2.000	-0.028	40.000	39.396	105.500	27.000	26.009
3.000	1.118	0.0	-0.528	105.500	23.500	23.366
3.000	0.976	10.000	9.388	105.500	27.000	25.922
3.000	0.894	20.000	19.340	105.500	29.000	27.956
3.000	0.652	30.000	29.197	105.500	35.000	35.041
3.000	0.490	40.000	39.101	105.500	39.000	38.100
4.000	1.316	0.0	-0.706	105.500	31.000	29.024
4.000	1.533	10.000	9.127	105.500	38.000	37.006
4.000	1.392	20.000	19.043	105.500	41.500	40.562
4.000	1.169	30.000	28.911	105.500	47.000	48.132
4.000	1.088	40.000	38.863	105.500	49.000	48.177
6.000	3.032	0.0	-1.170	105.500	50.500	49.572
6.000	2.810	10.000	3.699	105.500	56.000	55.143
6.000	2.567	20.000	18.555	105.500	62.000	61.218
6.000	2.405	30.000	28.459	105.500	65.000	65.277
6.000	2.565	40.000	38.554	105.500	67.000	61.276
8.000	4.349	0.0	-1.574	105.500	67.500	66.702
8.000	4.167	10.000	8.318	105.500	72.000	71.265
8.000	4.005	20.000	18.222	105.500	76.000	75.325
8.000	3.883	30.000	28.150	105.500	79.000	78.377
8.000	3.962	40.000	38.197	105.500	77.000	76.392
10.000	5.802	0.0	-2.103	105.500	81.000	80.392
10.000	5.841	10.000	38.126	105.500	80.000	79.413

SCHWINN 27XL-1/4 PUFF ROAD RACER (NATIONAL)

SLIP ANGLE BIAS = 0.723

MEASURED SLIP ANGLE	CORRECTED SLIP ANGLE	MEASURED INCLINATION ANGLE	CORRECTED INCLINATION ANGLE	NORMAL FORCE	MEASURED LATERAL FORCE	CORRECTED LATERAL FORCE
-3.000	-2.134	0.0	0.348	36.400	-14.500	-14.767
-3.000	-2.074	6.000	6.384	36.400	-16.000	-16.261
-3.000	-2.196	15.000	15.312	36.400	-13.000	-13.212
-3.000	-2.076	25.000	25.392	36.400	-16.000	-16.206
-3.000	-1.997	35.000	35.429	36.400	-13.000	-13.192
-1.000	-1.295	0.0	0.253	36.400	-10.500	-10.736
-1.000	-1.275	6.000	6.245	36.400	-11.000	-11.223
-1.000	-1.357	15.000	15.217	36.400	-9.000	-9.182
-1.000	-1.277	25.000	25.264	36.400	-11.000	-11.168
-1.000	-1.198	35.000	35.310	36.400	-13.000	-13.154
-0.500	-0.895	0.0	0.194	36.400	-8.000	-8.217
-0.500	-0.936	6.000	6.170	36.400	-7.000	-7.192
-0.500	-0.837	15.000	15.173	36.400	-8.000	-8.174
-0.500	-0.858	25.000	25.192	36.400	-9.000	-8.145
-0.500	-0.859	35.000	35.215	36.400	-9.000	-9.124
0.0	-0.656	0.0	0.099	36.400	-4.000	-4.187
0.0	-0.637	6.000	6.110	36.400	-4.500	-4.673
0.0	-0.658	15.000	15.098	36.400	-4.000	-4.143
0.0	-0.659	25.000	25.097	36.400	-4.000	-4.114
0.0	-0.480	35.000	35.144	36.400	-6.000	-6.101
0.500	-0.156	0.0	0.039	36.400	-1.500	-1.669
0.500	-0.137	6.000	5.951	36.400	-2.000	-2.156
0.500	-0.218	15.000	15.033	36.400	0.0	-0.113
0.500	-0.159	25.000	25.038	36.400	-1.500	-1.595
0.500	-0.261	35.000	34.978	36.400	1.000	0.953
1.000	0.243	0.0	-0.020	36.400	1.000	0.951
1.000	0.232	6.000	5.956	36.400	2.000	1.976
1.000	0.161	15.000	14.931	36.400	3.000	2.910
1.000	0.240	25.000	24.978	36.400	1.000	0.924
1.000	0.118	35.000	34.936	36.400	4.000	3.976
2.000	0.921	0.0	-0.210	36.400	3.000	8.912
2.000	0.961	6.000	5.813	36.400	3.000	7.929
2.000	1.000	15.000	14.836	36.400	7.000	6.941
2.000	0.959	25.000	24.812	36.400	3.000	7.977
2.000	0.797	35.000	34.716	36.400	12.000	12.037
3.000	1.720	0.0	-0.329	36.400	14.000	13.951
3.000	1.720	6.000	5.670	36.400	14.000	13.968
3.000	1.719	15.000	14.670	36.400	14.000	13.994
3.000	1.798	25.000	24.717	36.400	12.000	12.008
3.000	1.475	35.000	34.576	36.400	20.000	20.098
4.000	2.479	0.0	-0.472	36.400	20.000	19.996
4.000	2.519	6.000	5.551	36.400	19.000	19.006
4.000	2.658	15.000	14.575	36.400	18.000	18.024
4.000	2.677	25.000	24.645	36.400	15.000	15.031
4.000	2.395	35.000	34.478	36.400	22.000	22.113
6.000	4.117	0.0	-0.686	36.400	29.000	29.065
6.000	4.358	6.000	5.456	36.400	23.000	23.037
6.000	4.317	15.000	14.432	36.400	24.000	24.070
6.000	4.516	25.000	24.550	36.400	19.000	19.061
6.000	4.354	35.000	34.454	36.400	23.000	23.120
-2.000	-1.853	0.0	0.514	73.400	-21.000	-21.796
-2.000	-1.874	6.000	6.502	73.400	-20.500	-21.275
-2.000	-1.976	15.000	15.442	73.400	-18.000	-18.729
-2.000	-1.856	25.000	25.513	73.400	-21.000	-21.723
-2.000	-1.978	35.000	35.441	73.400	-19.000	-19.671
-1.000	-1.054	0.0	0.395	73.400	-16.000	-16.759
-1.000	-1.055	6.000	6.335	73.400	-16.000	-16.740
-1.000	-1.257	15.000	15.276	73.400	-11.000	-11.676
-1.000	-1.178	25.000	25.322	73.400	-13.000	-13.662
-1.000	-1.259	35.000	35.274	73.400	-11.000	-11.618
-0.500	-0.715	0.0	0.300	73.400	-12.000	-12.727
-0.500	-0.776	6.000	6.254	73.400	-10.500	-11.199
-0.500	-0.878	15.000	15.224	73.400	-8.000	-8.653
-0.500	-0.839	25.000	25.227	73.400	-9.000	-9.632
-0.500	-1.041	35.000	35.128	73.400	-4.000	-4.565
0.0	-0.376	0.0	0.225	73.400	-3.000	-3.697
0.0	-0.477	6.000	6.145	73.400	-5.500	-6.160
0.0	-0.659	15.000	15.097	73.400	-3.500	-4.119
0.0	-0.650	25.000	25.097	73.400	-3.500	-4.090
0.0	-0.621	35.000	35.060	73.400	-2.000	-2.549
0.500	-0.117	0.0	0.063	73.400	-2.000	-2.651
0.500	-0.198	6.000	6.015	73.400	0.0	-0.618
0.500	-0.260	15.000	14.978	73.400	1.500	0.919
0.500	-0.241	25.000	24.990	73.400	1.000	0.444
0.500	-0.483	35.000	34.846	73.400	7.000	6.519
1.000	0.222	0.0	-0.033	73.400	2.000	1.380
1.000	0.060	6.000	5.872	73.400	6.000	5.428
1.000	0.019	15.000	14.848	73.400	7.000	6.461
1.000	0.078	25.000	24.882	73.400	5.500	4.979
1.000	-0.184	35.000	34.727	73.400	12.000	11.557
2.000	0.900	0.0	-0.223	73.400	10.000	9.441
2.000	0.779	6.000	5.705	73.400	13.000	12.481
2.000	0.738	15.000	14.631	73.400	14.000	13.515
2.000	0.696	25.000	24.657	73.400	15.000	14.551
2.000	0.414	35.000	34.489	73.400	22.000	21.634
3.000	1.418	0.0	-0.508	73.400	22.000	21.532
3.000	1.457	6.000	5.515	73.400	21.000	20.542
3.000	1.416	15.000	14.491	73.400	22.000	21.576
3.000	1.274	25.000	24.407	73.400	25.500	25.131

SCHWINN 27X1-1/4 PUFF ROAD RACER (NATIONAL)

MEASURED SLIP ANGLE	CORRECTED SLIP ANGLE	MEASURED INCLINATION ANGLE	CORRECTED INCLINATION ANGLE	NORMAL FORCE	MEASURED LATERAL FORCE	CORRECTED LATERAL FORCE
3.000	0.931	35.000	34.204	73.400	34.000	33.725
4.000	2.096	0.0	-0.698	73.400	30.000	29.593
4.000	2.116	6.000	5.313	73.400	29.500	29.107
4.000	2.135	15.000	14.324	73.400	29.000	28.629
4.000	2.093	25.000	24.300	73.400	30.000	29.666
4.000	1.630	35.000	34.026	73.400	41.500	41.282
6.000	3.533	0.0	-1.031	73.400	44.000	43.700
6.000	3.653	6.000	5.040	73.400	41.000	40.695
6.000	3.652	15.000	14.039	73.400	41.000	40.721
6.000	3.731	25.000	24.786	73.400	39.000	38.734
6.000	3.409	35.000	33.895	73.400	47.000	46.824
-2.000	-1.666	0.0	0.625	105.500	-25.000	-26.504
-2.000	-1.767	6.000	6.566	105.500	-22.500	-23.967
-2.000	-1.828	15.000	15.529	105.500	-21.000	-22.430
-2.000	-1.749	25.000	25.576	105.500	-23.000	-24.416
-2.000	-2.072	35.000	35.385	105.500	-15.000	-16.326
-1.000	-0.907	0.0	0.483	105.500	-19.000	-20.458
-1.000	-1.028	6.000	6.411	105.500	-16.000	-17.418
-1.000	-1.170	15.000	15.327	105.500	-12.500	-13.865
-1.000	-1.151	25.000	25.338	105.500	-13.000	-14.340
-1.000	-1.474	35.000	35.147	105.500	-5.000	-6.250
-0.500	-0.588	0.0	0.376	105.500	-14.500	-15.924
-0.500	-0.729	6.000	6.292	105.500	-11.000	-12.379
-0.500	-0.811	15.000	15.244	105.500	-9.000	-10.338
-0.500	-0.832	25.000	25.231	105.500	-8.500	-9.805
-0.500	-1.205	35.000	34.957	105.500	3.000	1.811
0.0	-0.309	0.0	0.245	105.500	-9.000	-10.387
0.0	-0.390	6.000	6.197	105.500	-7.000	-8.349
0.0	-0.552	15.000	15.101	105.500	-3.000	-4.292
0.0	-0.633	25.000	25.053	105.500	-1.000	-2.248
0.0	-0.916	35.000	34.886	105.500	6.000	4.834
0.500	-0.050	0.0	0.172	105.500	-3.000	-4.336
0.500	-0.010	6.000	6.126	105.500	-4.000	-5.326
0.500	-0.293	15.000	14.959	105.500	3.000	1.753
0.500	-0.415	25.000	24.897	105.500	5.000	4.805
0.500	-0.657	35.000	34.743	105.500	12.000	10.880
1.000	0.209	0.0	-0.047	105.500	3.000	1.710
1.000	0.067	6.000	5.876	105.500	6.500	5.254
1.000	-0.094	15.000	14.790	105.500	10.500	9.311
1.000	-0.035	25.000	24.915	105.500	9.000	7.828
1.000	-0.559	35.000	34.505	105.500	22.000	20.956
2.000	0.807	0.0	-0.278	105.500	13.000	11.786
2.000	0.706	6.000	5.662	105.500	15.500	14.323
2.000	0.644	15.000	14.676	105.500	17.000	15.860
2.000	0.502	25.000	24.542	105.500	20.500	19.416
2.000	0.119	35.000	34.315	105.500	30.000	29.017
3.000	1.204	0.0	-0.635	105.500	28.000	26.901
3.000	1.283	6.000	5.412	105.500	26.000	24.903
3.000	1.202	15.000	14.364	105.500	23.000	26.944
3.000	1.020	25.000	24.256	105.500	32.500	31.507
3.000	0.516	35.000	33.958	105.500	45.000	44.132
4.000	1.802	0.0	-0.873	105.500	38.000	36.977
4.000	2.082	6.000	5.293	105.500	31.000	29.941
4.000	1.840	15.000	14.150	105.500	37.000	36.013
4.000	1.598	25.000	24.007	105.500	43.000	42.087
4.000	1.195	35.000	33.768	105.500	53.000	52.193
6.000	3.379	0.0	-1.122	105.500	48.500	47.557
6.000	3.238	6.000	4.794	105.500	42.000	41.101
6.000	3.157	15.000	13.746	105.500	54.000	53.142
6.000	3.075	25.000	23.698	105.500	56.000	55.187
6.000	2.551	35.000	33.388	105.500	69.000	68.315

ELEMENT #50 ROAD TIRE (27 IN. SEW-UP)

SLIP ANGLE BIAS = 0.940

MEASURED SLIP ANGLE	CORRECTED SLIP ANGLE	MEASURED INCLINATION ANGLE	CORRECTED INCLINATION ANGLE	NORMAL FORCE	MEASURED LATERAL FORCE	CORRECTED LATERAL FORCE
-3.000	-3.009	0.0	0.497	37.150	-20.750	-21.071
-3.000	-2.950	0.0	0.822	70.250	-34.000	-34.842
-3.000	-2.210	0.0	1.023	104.500	-41.750	-43.357
-3.000	-3.110	10.000	10.491	37.150	-20.500	-20.790
-3.000	-2.651	10.000	10.762	70.250	-31.500	-32.293
-3.000	-2.392	10.000	10.916	104.500	-37.250	-38.793
-3.000	-3.281	20.000	20.508	37.150	-21.250	-21.517
-3.000	-2.653	20.000	20.751	70.250	-31.500	-32.265
-3.000	-2.604	20.000	20.849	104.500	-34.500	-35.993
-3.000	-3.093	30.000	30.501	37.150	-21.000	-21.236
-3.000	-2.694	30.000	30.737	70.250	-30.500	-31.228
-3.000	-2.654	30.000	30.755	104.500	-31.250	-31.984
-3.000	-2.945	30.000	30.825	104.500	-33.500	-34.957
-3.000	-3.144	40.000	40.471	37.150	-19.750	-19.948
-3.000	-2.705	40.000	40.730	70.250	-30.250	-30.947
-3.000	-2.667	40.000	40.753	104.500	-30.500	-31.905
-3.000	-3.164	40.000	40.447	37.150	-18.750	-18.940
-3.000	-2.705	40.000	40.730	70.250	-30.250	-30.947
-3.000	-2.667	40.000	40.741	104.500	-30.000	-31.401
-2.000	-2.250	0.0	0.408	37.150	-17.000	-17.292
-2.000	-1.471	0.0	0.632	70.250	-26.000	-26.780
-2.000	-1.662	0.0	0.756	104.500	-30.500	-32.021
-2.000	-2.291	10.000	10.384	37.150	-16.000	-16.256
-2.000	-1.493	10.000	10.566	70.250	-23.250	-23.981
-2.000	-1.814	10.000	10.666	104.500	-26.750	-28.213
-2.000	-2.242	20.000	20.413	37.150	-17.250	-17.486
-2.000	-1.504	20.000	20.577	70.250	-23.750	-24.455
-2.000	-1.294	20.000	20.647	104.500	-26.000	-27.429
-2.000	-2.274	30.000	30.394	37.150	-16.500	-16.702
-2.000	-1.565	30.000	30.565	70.250	-23.250	-23.923
-2.000	-1.657	30.000	30.581	104.500	-23.250	-24.629
-2.000	-2.305	40.000	40.340	37.150	-14.250	-14.406
-2.000	-2.089	40.000	40.534	70.250	-22.000	-22.634
-2.000	-1.401	40.000	40.503	104.500	-20.000	-21.325
-1.000	-1.143	0.0	0.319	37.150	-13.250	-13.514
-1.000	-0.494	0.0	0.472	70.250	-19.250	-19.979
-1.000	-1.492	10.000	0.360	104.500	-22.250	-23.708
-1.000	-1.255	10.000	10.289	37.150	-12.000	-12.225
-1.000	-1.156	10.000	10.405	70.250	-16.500	-17.179
-1.000	-1.413	20.000	10.464	104.500	-18.250	-19.648
-1.000	-1.236	20.000	20.312	37.150	-13.000	-13.204
-1.000	-1.207	20.000	20.417	70.250	-17.000	-17.654
-1.000	-1.414	30.000	20.433	104.500	-17.000	-18.360
-1.000	-1.277	30.000	30.311	37.150	-13.000	-13.175
-1.000	-1.319	30.000	30.392	70.250	-16.000	-16.617
-1.000	-1.456	30.000	30.367	104.500	-14.250	-15.560
-1.000	-1.338	40.000	40.286	37.150	-12.000	-12.139
-1.000	-1.421	40.000	40.356	70.250	-14.500	-15.077
0.0	-0.012	0.0	0.007	104.500	-11.750	-13.012
0.0	-0.404	0.0	0.194	37.150	-8.000	-8.224
0.0	-0.406	0.0	0.281	70.250	-11.250	-11.918
0.0	-0.673	10.000	0.316	104.500	-12.000	-13.380
0.0	-0.366	10.000	10.158	37.150	-6.500	-6.683
0.0	-0.543	10.000	10.221	70.250	-8.750	-9.370
0.0	-0.614	20.000	10.232	104.500	-8.500	-9.824
0.0	-0.577	20.000	20.193	37.150	-8.000	-8.166
0.0	-0.594	20.000	20.214	70.250	-8.500	-9.089
0.0	-0.615	30.000	20.201	104.500	-7.250	-8.536
0.0	-0.619	30.000	30.192	37.150	-8.000	-8.137
0.0	-0.731	30.000	30.190	70.250	-7.500	-8.052
0.0	-0.657	40.000	30.123	104.500	-4.000	-5.232
0.0	-0.650	40.000	40.166	37.150	-7.000	-7.100
0.0	-0.763	40.000	40.172	70.250	-6.750	-7.268
1.000	0.077	0.0	0.105	104.500	-3.250	-4.447
1.000	0.123	0.0	0.010	37.150	-0.250	-0.415
1.000	0.152	0.0	0.038	70.250	-1.000	-1.590
1.000	0.025	10.000	0.054	104.500	-1.000	-2.296
1.000	0.062	10.000	10.015	37.150	-0.500	-0.638
1.000	0.019	10.000	10.001	70.250	0.500	-0.049
1.000	0.145	20.000	20.050	104.500	2.500	1.260
1.000	0.101	20.000	20.050	37.150	-2.000	-2.120
1.000	0.017	20.000	20.024	70.250	-0.500	-1.028
1.000	0.113	30.000	30.076	104.500	2.250	1.037
1.000	0.063	30.000	30.032	37.150	-1.250	-1.335
1.000	-0.153	30.000	29.983	70.250	1.000	0.512
1.000	0.122	40.000	29.874	104.500	6.500	5.348
1.000	-0.072	40.000	40.037	37.150	-1.500	-1.558
1.000	-0.295	40.000	39.922	70.250	3.750	3.312
2.000	0.835	0.0	3.790	104.500	10.000	8.904
2.000	0.702	0.0	-0.133	37.150	5.750	5.631
2.000	0.739	0.0	-0.177	70.250	8.000	7.479
2.000	0.854	10.000	-0.196	104.500	9.500	8.284
2.000	0.790	10.000	0.849	37.150	6.500	6.416
2.000	0.628	10.000	0.787	70.250	9.500	9.019
2.000	0.933	20.000	0.744	104.500	12.000	10.832
2.000	0.765	20.000	1.907	37.150	4.000	3.926
2.000	0.627	20.000	1.923	70.250	7.750	7.285
2.000	0.862	20.000	1.744	104.500	12.000	10.861
2.000	0.862	30.000	2.7895	37.150	4.500	4.458

CLEMENT #50 ROAD TIRE (27 IN. SET-UP)

MEASURED SLIP ANGLE	CORRECTED SLIP ANGLE	MEASURED INCLINATION ANGLE	CORRECTED INCLINATION ANGLE	NORMAL FORCE	MEASURED LATERAL FORCE	CORRECTED LATERAL FORCE
2.000	0.658	30.000	29.786	70.250	9.500	9.077
2.000	0.465	30.000	29.648	104.500	16.000	14.921
2.000	0.871	40.000	39.888	37.150	4.750	4.739
2.000	0.616	40.000	39.738	70.250	11.500	11.121
2.000	0.354	40.000	39.582	104.500	18.750	17.721
3.000	1.534	0.0	-0.311	37.150	13.250	13.188
3.000	1.319	0.0	-0.438	70.250	19.000	18.563
3.000	1.217	0.0	-0.499	104.500	22.250	21.132
3.000	1.543	10.000	9.694	37.150	13.000	12.965
3.000	1.273	10.000	9.537	70.250	20.000	19.599
3.000	1.125	10.000	9.447	104.500	24.500	23.428
3.000	1.511	20.000	19.675	37.150	13.750	13.750
3.000	1.277	20.000	19.537	70.250	20.000	19.628
3.000	1.064	20.000	19.411	104.500	26.000	24.968
3.000	1.540	30.000	29.693	37.150	13.000	13.023
3.000	1.246	30.000	29.518	70.250	20.750	20.413
3.000	1.210	30.000	29.500	70.250	21.500	21.169
3.000	1.043	30.000	29.398	104.500	26.500	25.501
3.000	1.020	40.000	39.740	37.150	11.000	11.037
3.000	1.295	40.000	39.547	70.250	19.500	19.182
3.000	0.721	40.000	39.326	104.500	29.500	28.553
3.000	2.323	0.0	-0.436	37.150	18.500	18.478
3.000	2.028	0.0	-0.610	70.250	26.250	25.868
3.000	1.855	0.0	-0.713	104.500	31.250	30.200
3.000	2.383	0.0	-0.400	37.150	17.000	16.967
3.000	2.058	0.0	-0.593	70.250	25.500	25.112
3.000	1.385	0.0	-0.695	104.500	30.500	29.445
3.000	2.342	10.000	9.575	37.150	18.000	18.003
3.000	1.936	10.000	9.335	70.250	28.500	28.164
3.000	1.703	10.000	9.197	104.500	35.000	34.008
3.000	2.320	20.000	19.563	37.150	18.500	18.536
3.000	1.975	20.000	19.353	70.250	27.500	27.186
3.000	1.722	20.000	19.209	104.500	34.500	33.533
3.000	2.239	30.000	29.514	37.150	20.500	20.580
3.000	1.354	30.000	29.286	70.250	30.500	30.237
3.000	1.570	30.000	29.119	104.500	38.250	37.340
3.000	2.312	40.000	39.561	37.150	18.500	18.594
3.000	1.872	40.000	39.298	70.250	30.000	29.763
3.000	1.499	40.000	39.076	104.500	40.000	39.133
3.000	4.102	0.0	-0.567	37.150	24.000	24.020
3.000	3.495	0.0	-0.926	70.250	39.500	39.219
3.000	3.192	0.0	-1.111	104.500	48.000	47.078
3.000	4.181	10.000	9.480	37.150	22.000	22.034
3.000	3.494	10.000	9.074	70.250	39.500	39.248
3.000	3.060	10.000	8.829	104.500	50.500	49.626
3.000	4.059	20.000	19.442	37.150	24.000	24.078
3.000	3.392	20.000	19.014	70.250	42.000	41.796
3.000	2.958	20.000	18.757	104.500	53.500	52.678
3.000	3.937	30.000	29.336	37.150	28.000	28.138
3.000	3.210	30.000	29.906	70.250	46.500	46.359
3.000	2.736	30.000	28.625	104.500	59.000	58.249
3.000	4.177	40.000	39.478	37.150	22.000	22.121
3.000	3.450	40.000	39.048	70.250	40.500	40.343
3.000	2.654	40.000	38.577	104.500	61.000	60.293
3.000	6.001	0.0	-0.626	37.150	26.500	26.539
3.000	5.194	0.0	-1.104	70.250	47.000	46.776
3.000	4.659	0.0	-1.420	104.500	61.000	60.177
3.000	6.020	10.000	9.385	37.150	26.000	26.064
3.000	5.192	10.000	8.895	70.250	47.000	46.805
3.000	4.537	10.000	8.503	104.500	64.000	63.229
3.000	6.079	20.000	19.420	37.150	24.500	24.582
3.000	5.051	20.000	18.811	70.250	50.500	50.361
3.000	4.335	20.000	18.388	104.500	69.000	68.296
3.000	5.937	30.000	29.336	37.150	28.000	28.138
3.000	4.828	30.000	28.680	70.250	56.000	55.932
3.000	4.133	30.000	28.269	104.500	74.000	73.363
3.000	6.017	40.000	39.333	37.150	26.000	26.151
3.000	5.591	40.000	39.131	70.250	37.000	36.816
3.000	4.574	40.000	38.530	104.500	63.000	62.308
3.000	7.860	0.0	-0.710	37.150	30.000	30.066
3.000	7.033	0.0	-1.199	70.250	51.000	50.807
3.000	6.297	0.0	-1.634	104.500	70.000	69.246
3.000	8.162	0.0	-0.531	37.150	22.500	22.509
3.000	7.053	0.0	-1.187	70.250	50.500	50.303
3.000	6.136	0.0	-1.729	104.500	74.000	73.276
3.000	8.182	0.0	-0.519	37.150	22.000	22.005
3.000	7.073	0.0	-1.175	70.250	50.000	49.799
3.000	6.056	0.0	-1.753	104.500	75.000	74.284
3.000	7.941	0.0	-0.662	37.150	28.000	28.051
3.000	7.073	0.0	-1.175	70.250	50.000	49.799
3.000	5.975	0.0	-1.824	104.500	73.000	72.307
3.000	6.116	0.0	-1.741	104.500	74.500	74.780

SCHWINN 27X1-1/4 PUFF ROAD RACER RADIAL

SLIP ANGLE BIAS = 1.110

MEASURED SLIP ANGLE	CORRECTED SLIP ANGLE	MEASURED INCLINATION ANGLE	CORRECTED INCLINATION ANGLE	NORMAL FORCE	MEASURED LATERAL FORCE	CORRECTED LATERAL FORCE
-3.000	-3.450	0.0	0.390	37.150	-16.250	-16.537
-3.000	-3.273	0.0	0.495	70.250	-20.250	-20.987
-3.000	-3.194	0.0	0.542	104.500	-21.500	-22.952
-3.000	-3.471	10.000	10.378	37.150	-15.750	-16.004
-3.000	-3.374	10.000	10.435	70.250	-17.750	-18.439
-3.000	-3.376	10.000	10.434	104.500	-17.000	-18.389
-3.000	-3.493	20.000	20.365	37.150	-15.250	-15.471
-3.000	-3.446	20.000	20.393	70.250	-16.000	-16.646
-3.000	-4.584	20.000	19.720	104.500	13.000	11.869
-3.000	-3.393	30.000	30.424	37.150	-17.750	-17.961
-3.000	-3.383	30.000	30.430	37.150	-18.000	-18.213
-3.000	-3.457	30.000	30.386	70.250	-15.750	-16.365
-3.000	-3.670	30.000	30.260	104.500	-9.750	-11.026
-3.000	-3.384	40.000	40.429	37.150	-18.000	-18.184
-3.000	-3.529	40.000	40.344	70.250	-14.000	-14.573
-3.000	-3.802	40.000	40.182	104.500	-6.500	-7.722
-2.000	-2.591	0.0	0.307	37.150	-12.750	-13.010
-2.000	-2.484	0.0	0.370	70.250	-15.000	-15.697
-2.000	-2.395	0.0	0.423	104.500	-16.500	-17.914
-2.000	-2.622	10.000	10.289	37.150	-12.000	-12.225
-2.000	-2.605	10.000	10.298	70.250	-12.000	-12.645
-2.000	-2.628	10.000	10.285	104.500	-10.750	-12.091
-2.000	-2.674	20.000	20.258	37.150	-10.750	-10.937
-2.000	-2.727	20.000	20.226	70.250	-9.000	-9.593
-2.000	-2.850	20.000	20.154	104.500	-5.250	-6.520
-2.000	-2.614	30.000	30.293	37.150	-12.250	-12.419
-2.000	-2.779	30.000	30.196	70.250	-7.750	-8.304
-2.000	-2.987	30.000	30.076	104.500	-2.000	-3.217
-2.000	-2.585	40.000	40.310	37.150	-13.000	-13.146
-2.000	-2.850	40.000	40.154	70.250	-6.000	-6.512
-2.000	-3.144	40.000	39.980	104.500	2.000	0.843
-1.000	-1.742	0.0	0.218	37.150	-9.000	-9.231
-1.000	-1.675	0.0	0.257	70.250	-10.250	-10.910
-1.000	-1.626	0.0	0.286	104.500	-10.750	-12.120
-1.000	-1.793	10.000	10.187	37.150	-7.750	-7.943
-1.000	-1.827	10.000	10.168	70.250	-6.500	-7.103
-1.000	-1.889	10.000	10.131	104.500	-4.250	-5.542
-1.000	-1.824	20.000	20.169	37.150	-7.000	-7.158
-1.000	-1.918	20.000	20.113	70.250	-4.250	-4.807
-1.000	-2.081	20.000	20.017	104.500	0.500	-0.726
-1.000	-1.805	30.000	30.180	37.150	-7.500	-7.633
-1.000	-2.030	30.000	30.047	70.250	-1.500	-2.087
-1.000	-2.263	30.000	29.909	104.500	5.000	3.837
-1.000	-1.807	40.000	40.179	37.150	-7.500	-7.604
-1.000	-2.112	40.000	39.987	70.250	1.000	0.541
-1.000	-2.465	40.000	39.790	104.500	10.000	8.904
0.0	-0.877	0.0	0.141	37.150	-5.750	-5.957
0.0	-0.856	0.0	0.150	70.250	-5.750	-6.376
0.0	-0.827	0.0	0.167	104.500	-5.750	-7.082
0.0	-0.964	10.000	10.086	37.150	-3.500	-3.661
0.0	-1.038	10.000	10.043	70.250	-1.250	-1.813
0.0	-1.110	10.000	10.000	104.500	1.250	0.000
0.0	-0.985	20.000	20.074	37.150	-3.000	-3.128
0.0	-1.159	20.000	19.971	70.250	1.750	1.239
0.0	-1.362	20.000	19.851	104.500	7.500	6.327
0.0	-1.006	30.000	30.061	37.150	-2.500	-2.595
0.0	-1.271	30.000	29.905	70.250	4.500	4.039
0.0	-1.545	30.000	29.743	104.500	12.000	10.890
0.0	-0.998	40.000	40.066	37.150	-2.750	-2.818
0.0	-1.373	40.000	39.845	70.250	7.000	6.587
0.0	-1.807	40.000	39.588	104.500	18.500	17.469
1.000	-0.053	0.0	0.034	37.150	-1.250	-1.422
1.000	-0.057	0.0	0.032	70.250	-0.750	-1.338
1.000	-0.069	0.0	0.024	104.500	0.250	-1.036
1.000	-0.145	10.000	9.979	37.150	1.000	0.874
1.000	-0.259	10.000	9.912	70.250	4.250	3.729
1.000	-0.361	10.000	9.851	104.500	7.500	6.298
1.000	-0.206	20.000	19.943	37.150	2.500	2.414
1.000	-0.411	20.000	19.822	70.250	8.000	7.537
1.000	-0.624	20.000	19.696	104.500	14.000	12.877
1.000	-0.224	30.000	29.930	37.150	3.000	2.947
1.000	-0.573	30.000	29.726	70.250	12.000	11.596
1.000	-0.866	30.000	29.553	104.500	20.000	18.951
1.000	-0.269	40.000	39.906	37.150	4.000	3.984
1.000	-0.735	40.000	39.631	70.250	16.000	15.656
1.000	-1.139	40.000	39.392	104.500	26.750	25.782
2.000	0.746	0.0	-0.085	37.150	3.750	3.616
2.000	0.712	0.0	-0.105	70.250	5.000	4.456
2.000	0.700	0.0	-0.112	104.500	6.000	4.758
2.000	0.654	10.000	9.860	37.150	6.000	5.912
2.000	0.510	10.000	9.775	70.250	10.000	9.523
2.000	0.408	10.000	9.715	104.500	13.250	12.092
2.000	0.653	20.000	19.860	37.150	6.000	5.941
2.000	0.388	20.000	19.703	70.250	13.000	12.575
2.000	0.175	20.000	19.577	104.500	19.000	17.915
2.000	0.571	30.000	29.812	37.150	8.000	7.985
2.000	0.186	30.000	29.584	70.250	18.000	17.642
2.000	-0.138	30.000	29.392	104.500	26.750	25.753
2.000	0.530	40.000	39.787	37.150	9.000	9.022

SCHWINN 27X1-1/4 PUFF ROAD RACER RADIAL

MEASURED SLIP ANGLE	CORRECTED SLIP ANGLE	MEASURED INCLINATION ANGLE	CORRECTED INCLINATION ANGLE	NORMAL FORCE	MEASURED LATERAL FORCE	CORRECTED LATERAL FORCE
2.000	0.024	40.000	39.488	70.250	22.000	21.701
2.000	-0.410	40.000	39.231	104.500	33.500	32.583
3.000	1.575	0.0	-0.186	37.150	8.000	7.898
3.000	1.491	0.0	-0.236	70.250	10.500	9.998
3.000	1.459	0.0	-0.255	104.500	12.000	10.803
3.000	1.443	10.000	9.736	37.150	11.250	11.202
3.000	1.249	10.000	9.621	70.250	16.500	16.073
3.000	1.126	10.000	9.548	104.500	20.250	19.145
3.000	1.412	20.000	19.717	37.150	12.000	11.987
3.000	1.107	20.000	19.537	70.250	20.000	19.628
3.000	0.864	20.000	19.393	104.500	26.750	25.724
3.000	1.290	30.000	29.645	37.150	15.000	15.038
3.000	0.895	30.000	29.411	70.250	25.250	24.947
3.000	0.531	30.000	29.196	104.500	35.000	34.066
3.000	1.249	40.000	39.621	37.150	16.000	16.075
3.000	0.702	40.000	39.298	70.250	30.000	29.763
3.000	0.248	40.000	39.029	104.500	42.000	41.148
4.000	2.414	0.0	-0.282	37.150	12.000	11.929
4.000	2.280	0.0	-0.361	70.250	15.750	15.288
4.000	2.238	0.0	-0.386	104.500	17.500	16.345
4.000	2.292	10.000	9.646	37.150	15.000	14.981
4.000	2.068	10.000	9.514	70.250	21.000	20.607
4.000	1.895	10.000	9.411	104.500	26.000	24.939
4.000	2.271	20.000	19.634	37.150	15.500	15.513
4.000	1.916	20.000	19.424	70.250	24.750	24.415
4.000	1.622	20.000	19.250	104.500	32.750	31.770
4.000	2.149	30.000	29.562	37.150	18.500	18.565
4.000	1.663	30.000	29.275	70.250	31.000	30.741
4.000	1.269	30.000	29.041	104.500	41.500	40.615
4.000	1.987	40.000	39.466	37.150	22.500	22.625
4.000	1.461	40.000	39.155	70.250	36.000	35.808
4.000	0.947	40.000	38.851	104.500	49.500	48.705
6.000	4.173	0.0	-0.424	37.150	18.000	17.975
6.000	3.948	0.0	-0.557	70.250	24.000	23.601
6.000	3.856	0.0	-0.612	104.500	27.000	25.918
6.000	4.051	10.000	9.504	37.150	21.000	21.026
6.000	3.716	10.000	9.306	70.250	29.750	29.424
6.000	3.513	10.000	9.186	104.500	35.500	34.512
6.000	4.050	20.000	19.503	37.150	21.000	21.055
6.000	4.010	20.000	19.479	70.250	22.000	22.063
6.000	3.584	20.000	19.228	104.500	33.000	32.728
6.000	3.230	20.000	19.018	37.150	42.500	41.594
6.000	3.928	30.000	29.431	37.150	24.000	24.107
6.000	4.069	30.000	29.514	70.250	20.500	20.580
6.000	3.322	30.000	29.072	104.500	39.500	39.306
6.000	2.807	30.000	28.768	37.150	53.000	52.203
6.000	3.686	40.000	39.288	37.150	30.000	30.182
6.000	2.999	40.000	38.881	70.250	47.500	47.396
6.000	2.444	40.000	38.553	104.500	62.000	61.301
8.000	6.012	0.0	-0.519	37.150	22.000	22.005
8.000	5.627	0.0	-0.747	70.250	32.000	31.662
8.000	5.494	0.0	-0.826	104.500	36.000	34.986
8.000	5.971	10.000	9.456	37.150	23.000	23.042
8.000	6.071	10.000	9.516	70.250	20.500	20.523
8.000	5.565	10.000	9.216	104.500	33.500	33.202
8.000	5.613	10.000	9.245	37.150	33.000	31.993
8.000	6.050	20.000	19.503	70.250	21.000	21.055
8.000	5.949	20.000	19.444	104.500	23.500	23.574
8.000	5.303	20.000	19.061	37.150	40.000	39.781
8.000	4.889	20.000	18.816	70.250	51.000	50.159
8.000	5.928	30.000	29.431	37.150	24.000	24.107
8.000	6.009	30.000	29.479	70.250	22.000	22.092
8.000	5.040	30.000	28.906	104.500	46.500	46.359
8.000	5.221	30.000	29.013	37.150	42.000	41.825
8.000	4.445	30.000	28.554	70.250	62.000	61.272
8.000	5.686	40.000	39.288	37.150	30.000	30.182
8.000	4.738	40.000	38.727	70.250	54.000	53.946
8.000	4.082	40.000	38.339	104.500	71.000	70.369
10.000	7.972	0.0	-0.543	37.150	23.000	23.013
10.000	7.385	0.0	-0.890	70.250	38.000	37.708
10.000	7.152	0.0	-1.028	104.500	44.500	43.551
10.000	8.051	10.000	9.504	37.150	21.000	21.026
10.000	7.143	10.000	8.967	70.250	44.000	43.782
10.000	6.769	10.000	8.746	104.500	54.000	53.153
10.000	7.969	20.000	19.456	37.150	23.000	23.071
10.000	7.021	20.000	18.895	70.250	47.000	46.834
10.000	6.547	20.000	18.614	104.500	59.500	58.724
10.000	8.029	30.000	29.491	37.150	21.500	21.588
10.000	8.109	30.000	29.538	70.250	19.500	19.573
10.000	6.819	30.000	28.775	104.500	52.000	51.901
10.000	6.164	30.000	28.388	37.150	69.000	68.325
10.000	6.204	30.000	28.411	70.250	68.000	67.317
10.000	7.766	40.000	39.335	37.150	28.000	28.167
10.000	6.818	40.000	38.774	70.250	52.000	51.930
10.000	6.082	40.000	38.339	104.500	71.000	70.369
10.000	6.002	40.000	38.292	37.150	73.000	72.385

SCHWINN 27X1-1/4 LETOUR

SLIP ANGLE BIAS = 1.540

MEASURED SLIP ANGLE	CORRECTED SLIP ANGLE	MEASURED INCLINATION ANGLE	CORRECTED INCLINATION ANGLE	NORMAL FORCE	MEASURED LATERAL FORCE	CORRECTED LATERAL FORCE
-3.000	-3.287	0.0	0.741	37.150	-31.000	-31.399
-3.000	-2.828	0.0	1.012	70.250	-42.000	-42.903
-3.000	-2.458	0.0	1.231	104.500	-50.500	-52.173
-3.000	-3.530	10.000	10.598	37.150	-25.000	-25.325
-3.000	-3.409	10.000	10.669	37.150	-28.000	-28.347
-3.000	-2.970	10.000	10.929	70.250	-38.500	-39.347
-3.000	-2.721	10.000	11.076	104.500	-44.000	-45.595
-3.000	-3.692	20.000	20.502	37.150	-21.000	-21.265
-3.000	-3.571	20.000	20.573	37.150	-24.000	-24.288
-3.000	-3.152	20.000	20.821	70.250	-34.000	-34.784
-3.000	-2.843	20.000	21.004	104.500	-41.000	-42.543
-3.000	-3.954	30.000	30.347	37.150	-14.500	-14.687
-3.000	-3.864	30.000	30.400	37.150	-16.750	-16.954
-3.000	-3.663	30.000	30.519	37.150	-21.750	-21.992
-3.000	-3.673	30.000	30.513	37.150	-21.500	-21.740
-3.000	-3.502	30.000	30.614	37.150	-25.750	-26.022
-3.000	-3.776	30.000	30.452	70.250	-18.500	-19.136
-3.000	-3.676	30.000	30.511	70.250	-21.000	-21.655
-3.000	-3.103	30.000	30.850	70.250	-35.250	-36.014
-3.000	-3.658	30.000	30.522	104.500	-20.750	-22.110
-3.000	-3.628	30.000	30.540	104.500	-21.500	-22.865
-3.000	-2.814	30.000	31.021	104.500	-41.750	-43.270
-3.000	-4.036	40.000	40.298	37.150	-12.500	-12.642
-3.000	-3.895	40.000	40.382	37.150	-16.000	-16.169
-3.000	-3.918	40.000	40.368	70.250	-15.000	-15.581
-3.000	-3.868	40.000	40.397	70.250	-16.250	-16.840
-3.000	-4.011	40.000	40.313	104.500	-12.000	-13.264
-2.000	-2.569	0.0	0.575	37.150	-24.000	-24.346
-2.000	-2.619	0.0	0.545	37.150	-22.750	-23.086
-2.000	-2.170	0.0	0.810	70.250	-33.500	-34.338
-2.000	-1.941	0.0	0.946	104.500	-38.500	-40.082
-2.000	-2.731	10.000	10.479	37.150	-20.000	-20.286
-2.000	-2.530	10.000	10.598	37.150	-25.000	-25.325
-2.000	-2.312	10.000	10.726	70.250	-30.000	-30.782
-2.000	-2.022	10.000	10.898	104.500	-36.500	-38.038
-2.000	-2.812	20.000	20.431	37.150	-18.000	-18.242
-2.000	-2.722	20.000	20.484	37.150	-20.250	-20.509
-2.000	-2.383	20.000	20.684	70.250	-28.250	-28.990
-2.000	-2.164	20.000	20.814	104.500	-33.000	-34.482
-2.000	-3.175	30.000	30.216	37.150	-9.000	-9.145
-2.000	-2.843	30.000	30.412	37.150	-17.250	-17.458
-2.000	-2.713	30.000	30.489	37.150	-20.500	-20.732
-2.000	-3.185	30.000	30.210	37.150	-8.750	-8.893
-2.000	-3.138	30.000	30.238	70.250	-9.500	-10.068
-2.000	-2.445	30.000	30.648	70.250	-26.750	-27.449
-2.000	-3.158	30.000	30.226	70.250	-9.000	-9.564
-2.000	-3.170	30.000	30.219	104.500	-8.000	-9.262
-2.000	-3.231	30.000	30.183	104.500	-6.500	-7.751
-2.000	-3.281	30.000	30.153	104.500	-5.250	-6.491
-2.000	-3.211	30.000	30.195	104.500	-7.000	-8.255
-2.000	-3.237	40.000	40.179	37.150	-7.500	-7.604
-2.000	-3.206	40.000	40.197	37.150	-8.250	-8.360
-2.000	-3.351	40.000	40.112	70.250	-4.250	-4.749
-2.000	-3.443	40.000	40.057	104.500	-1.250	-2.432
-1.000	-1.790	0.0	0.444	37.150	-18.500	-18.804
-1.000	-1.291	0.0	0.739	70.250	-30.500	-31.315
-1.000	-1.152	0.0	0.821	104.500	-33.250	-34.792
-1.000	-1.871	10.000	10.396	37.150	-16.500	-16.760
-1.000	-1.613	10.000	10.548	70.250	-22.900	-23.225
-1.000	-1.505	10.000	10.612	104.500	-24.500	-25.946
-1.000	-1.933	20.000	20.359	37.150	-15.000	-15.219
-1.000	-1.675	20.000	20.512	70.250	-21.000	-21.684
-1.000	-1.596	20.000	20.558	104.500	-22.250	-23.650
-1.000	-2.346	30.000	30.115	37.150	-4.750	-4.862
-1.000	-2.400	30.000	30.083	70.250	-3.000	-3.518
-1.000	-2.492	30.000	30.028	104.500	0.0	-1.201
-1.000	-2.468	40.000	40.043	37.150	-1.750	-1.810
-1.000	-2.441	40.000	40.059	70.250	-2.000	-2.482
-1.000	-2.614	40.000	39.956	104.500	3.000	1.851
0.0	-1.031	0.0	0.301	37.150	-12.500	-12.758
0.0	-0.874	0.0	0.394	70.250	-16.000	-16.704
0.0	-0.805	0.0	0.435	104.500	-17.000	-18.418
0.0	-1.062	10.000	10.283	37.150	-11.750	-11.973
0.0	-0.935	10.000	10.358	70.250	-14.500	-15.164
0.0	-0.947	10.000	10.351	104.500	-13.500	-14.862
0.0	-0.867	10.000	10.398	104.500	-15.500	-16.877
0.0	-1.084	20.000	20.270	37.150	-11.250	-11.441
0.0	-0.936	20.000	20.357	70.250	-14.500	-15.135
0.0	-0.898	20.000	20.380	104.500	-14.750	-16.093
0.0	-1.637	30.000	29.942	37.150	2.500	2.443
0.0	-1.802	30.000	29.845	70.250	7.000	6.558
0.0	-1.832	30.000	29.827	70.250	7.750	7.314
0.0	-1.964	30.000	29.749	104.500	11.750	10.638
0.0	-1.206	40.000	40.197	37.150	-8.250	-8.360
0.0	-1.280	40.000	40.154	70.250	-6.000	-6.512
0.0	-1.393	40.000	40.087	104.500	-2.500	-3.691
1.000	-0.353	0.0	0.111	37.150	-4.500	-4.697
1.000	-0.316	0.0	0.133	70.250	-5.000	-5.620
1.000	-0.288	0.0	0.149	104.500	-5.000	-6.326

SCHWINN 27X1-1/4 LETOUR

MEASURED SLIP ANGLE	CORRECTED SLIP ANGLE	MEASURED INCLINATION ANGLE	CORRECTED INCLINATION ANGLE	NORMAL FORCE	MEASURED LATERAL FORCE	CORRECTED LATERAL FORCE
1.000	-0.394	10.000	10.086	37.150	-3.500	-3.661
1.000	-0.357	10.000	10.108	70.250	-4.000	-4.584
1.000	-0.409	10.000	10.077	104.500	-2.000	-3.274
1.000	-0.325	20.000	20.127	37.150	-5.250	-5.395
1.000	-0.318	20.000	20.131	70.250	-5.000	-5.562
1.000	-0.360	20.000	20.106	104.500	-3.250	-4.505
1.000	-0.979	30.000	29.740	37.150	11.000	11.008
1.000	-1.244	30.000	29.584	70.250	18.000	17.642
1.000	-1.437	30.000	29.470	104.500	23.500	22.478
1.000	-0.488	40.000	40.031	37.150	-1.250	-1.307
1.000	-0.642	40.000	39.940	70.250	3.000	2.557
1.000	-0.805	40.000	39.843	104.500	7.750	6.637
1.000	-0.845	40.000	39.820	104.500	8.750	7.644
2.000	0.336	0.0	-0.073	37.150	3.250	3.112
2.000	0.312	0.0	-0.087	70.250	4.250	3.700
2.000	0.310	0.0	-0.088	104.500	5.000	3.750
2.000	0.264	10.000	9.884	37.150	5.000	4.904
2.000	0.191	10.000	9.841	70.250	7.250	6.752
2.000	0.138	10.000	9.810	104.500	9.250	8.061
2.000	0.384	20.000	19.955	37.150	2.000	1.910
2.000	0.320	20.000	19.917	70.250	4.000	3.506
2.000	0.228	20.000	19.863	104.500	7.000	5.873
2.000	-0.261	30.000	29.574	37.150	18.000	18.061
2.000	-0.586	30.000	29.382	70.250	26.500	26.207
2.000	-0.819	30.000	29.244	104.500	33.000	32.050
2.000	0.251	40.000	39.876	37.150	5.250	5.243
2.000	0.016	40.000	39.738	70.250	11.500	11.121
2.000	-0.187	40.000	39.617	104.500	17.250	16.209
3.000	0.944	0.0	-0.305	37.150	13.000	12.936
3.000	0.800	0.0	-0.391	70.250	17.000	16.548
3.000	0.758	0.0	-0.415	104.500	18.750	17.605
3.000	0.872	10.000	9.652	37.150	14.750	14.729
3.000	0.738	10.000	9.573	70.250	18.500	18.088
3.000	0.626	10.000	9.507	104.500	22.000	20.909
3.000	0.992	20.000	19.723	37.150	11.750	11.735
3.000	0.848	20.000	19.638	70.250	15.750	15.346
3.000	0.695	20.000	19.547	104.500	20.250	19.174
3.000	0.518	30.000	29.443	37.150	23.500	23.603
3.000	0.438	30.000	29.395	70.250	25.500	25.619
3.000	-0.008	30.000	29.132	104.500	37.000	36.787
3.000	-0.241	30.000	28.994	104.500	43.500	42.631
3.000	0.929	40.000	39.686	37.150	13.250	13.304
3.000	0.544	40.000	39.458	70.250	23.250	22.961
3.000	0.341	40.000	39.338	104.500	29.000	28.349
4.000	1.683	0.0	-0.460	37.150	19.500	19.446
4.000	1.418	0.0	-0.616	70.250	26.500	26.120
4.000	1.305	0.0	-0.683	104.500	30.000	28.941
4.000	1.571	10.000	9.474	37.150	22.250	22.286
4.000	1.316	10.000	9.323	70.250	29.000	28.668
4.000	1.194	10.000	9.251	104.500	32.750	31.741
4.000	1.751	20.000	19.580	37.150	17.750	17.781
4.000	1.720	20.000	19.563	70.250	18.500	18.536
4.000	1.690	20.000	19.545	104.500	19.250	19.292
4.000	1.426	20.000	19.388	70.250	26.250	25.926
4.000	1.243	20.000	19.280	104.500	31.500	30.510
4.000	1.317	30.000	29.324	37.150	28.500	28.641
4.000	0.630	30.000	28.918	70.250	46.000	45.856
4.000	0.317	30.000	28.732	104.500	54.500	53.714
4.000	1.608	40.000	39.496	37.150	21.250	21.365
4.000	1.192	40.000	39.250	70.250	32.000	31.778
4.000	0.929	40.000	39.094	104.500	39.250	38.377
4.000	0.889	40.000	39.071	104.500	40.250	39.385
6.000	3.260	0.0	-0.710	37.150	30.000	30.066
6.000	2.775	0.0	-0.997	70.250	42.500	42.242
6.000	2.501	0.0	-1.159	104.500	50.000	49.093
6.000	3.259	10.000	9.290	37.150	30.000	30.095
6.000	3.500	10.000	9.432	70.250	24.000	24.049
6.000	2.693	10.000	8.995	104.500	44.500	44.286
6.000	3.445	10.000	9.400	37.150	26.500	25.443
6.000	3.218	20.000	19.265	70.250	31.000	31.132
6.000	2.652	20.000	18.930	104.500	45.500	45.323
6.000	2.358	20.000	18.757	70.250	53.500	52.678
6.000	3.478	30.000	29.419	37.150	24.500	24.611
6.000	2.389	30.000	28.775	70.250	52.000	51.901
6.000	1.694	30.000	28.364	104.500	70.000	69.333
6.000	3.195	40.000	39.252	37.150	31.500	31.693
6.000	2.488	40.000	38.834	70.250	49.500	49.411
6.000	2.054	40.000	38.577	104.500	61.000	60.293
8.000	5.019	0.0	-0.852	37.150	36.000	36.117
8.000	4.352	0.0	-1.247	70.250	53.000	52.822
8.000	3.878	0.0	-1.527	104.500	65.500	64.712
8.000	5.259	10.000	9.290	37.150	30.000	30.095
8.000	4.412	10.000	8.788	70.250	51.500	51.340
8.000	3.957	10.000	8.520	104.500	63.500	62.725
8.000	5.238	20.000	19.277	37.150	30.500	30.628
8.000	4.310	20.000	18.728	70.250	54.000	53.888
8.000	3.675	20.000	18.353	104.500	70.500	69.808
8.000	5.458	30.000	29.407	37.150	25.000	25.115
8.000	4.148	30.000	28.632	70.250	58.000	57.947
8.000	3.493	30.000	28.245	104.500	75.000	74.371
8.000	5.256	40.000	39.288	37.150	30.000	30.182
8.000	4.408	40.000	38.786	70.250	51.500	51.427
8.000	4.046	40.000	38.572	104.500	60.500	60.495
8.000	3.512	40.000	38.256	37.150	74.500	73.896
10.000	7.100	0.0	-0.805	37.150	34.000	34.097
10.000	6.292	0.0	-1.282	70.250	54.500	54.334
10.000	5.637	0.0	-1.670	104.500	71.500	70.757
10.000	7.420	10.000	9.385	37.150	26.000	26.064
10.000	7.259	10.000	9.290	70.250	30.000	30.095
10.000	6.391	10.000	8.776	104.500	52.000	51.843
10.000	6.070	10.000	8.586	37.150	60.000	59.905
10.000	5.776	10.000	8.413	70.250	68.000	67.260
10.000	7.298	20.000	19.313	37.150	29.000	29.116
10.000	6.250	20.000	18.693	70.250	55.500	55.399
10.000	6.109	20.000	18.609	104.500	59.000	58.926
10.000	5.433	20.000	18.210	37.150	76.500	75.853
10.000	7.316	40.000	39.323	70.250	28.500	28.670
10.000	6.107	40.000	38.608	104.500	59.000	58.984
10.000	5.391	40.000	38.185	37.150	77.500	76.919

Appendix II
FULL SCALE EXPERIMENTAL TEST DATA

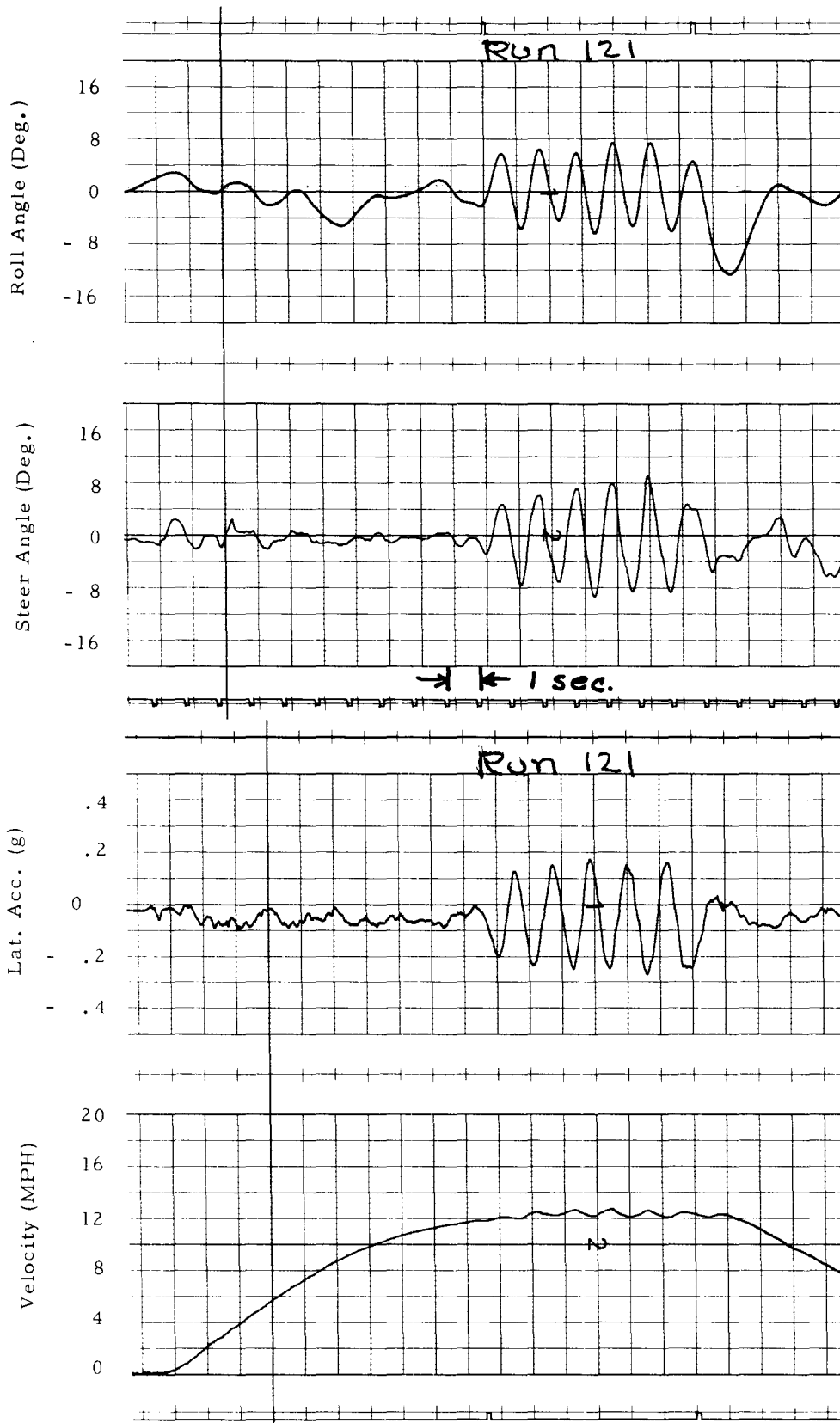

Figure II.1 Run 121 Narrow Slalom Course - Standard Bicycle

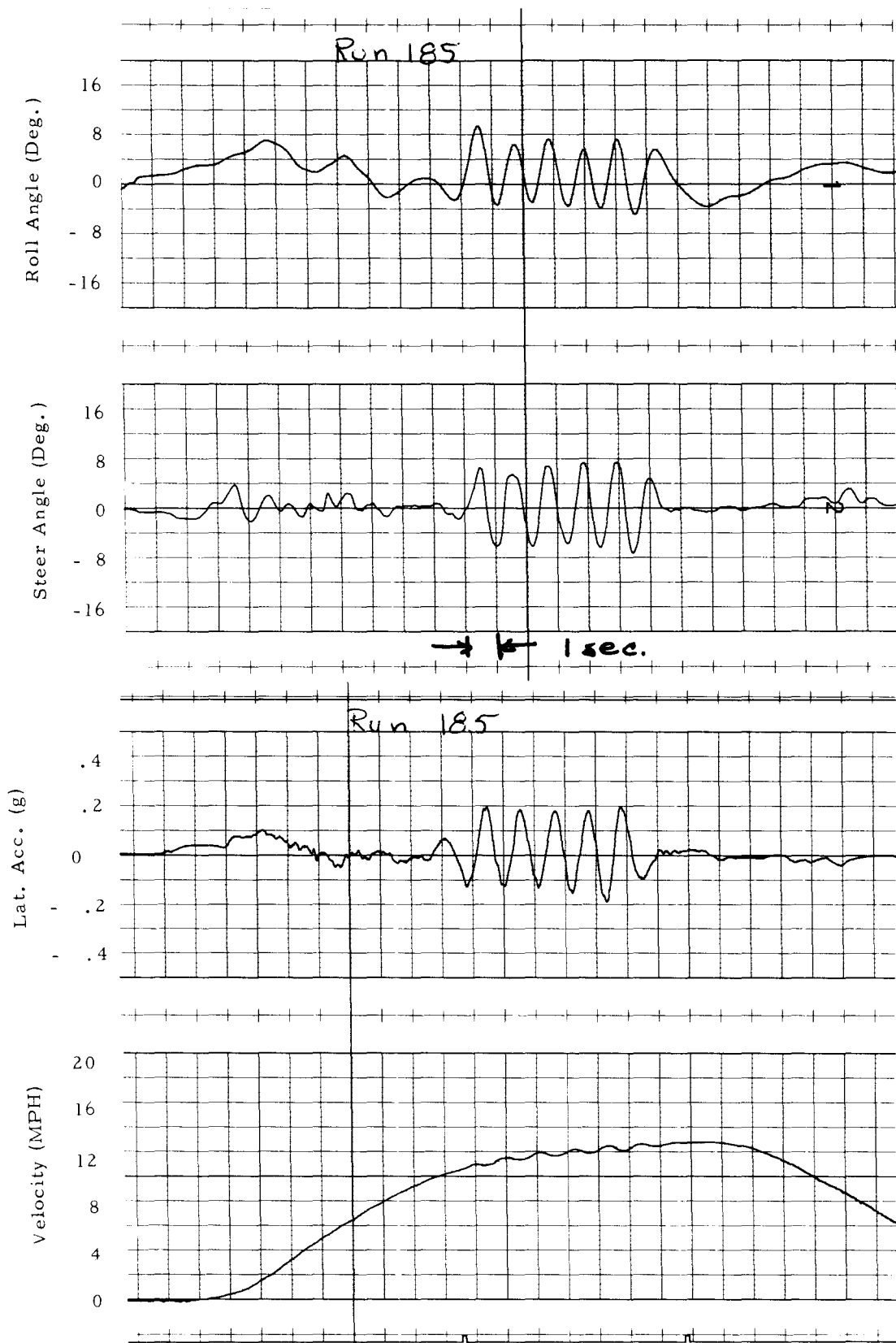

Figure II.2 Run 185 Narrow Slalom Course - High Wheel Spin Inertia



Figure II.3 Run 102, Narrow Slalom Course - Low Front Tire Pressure

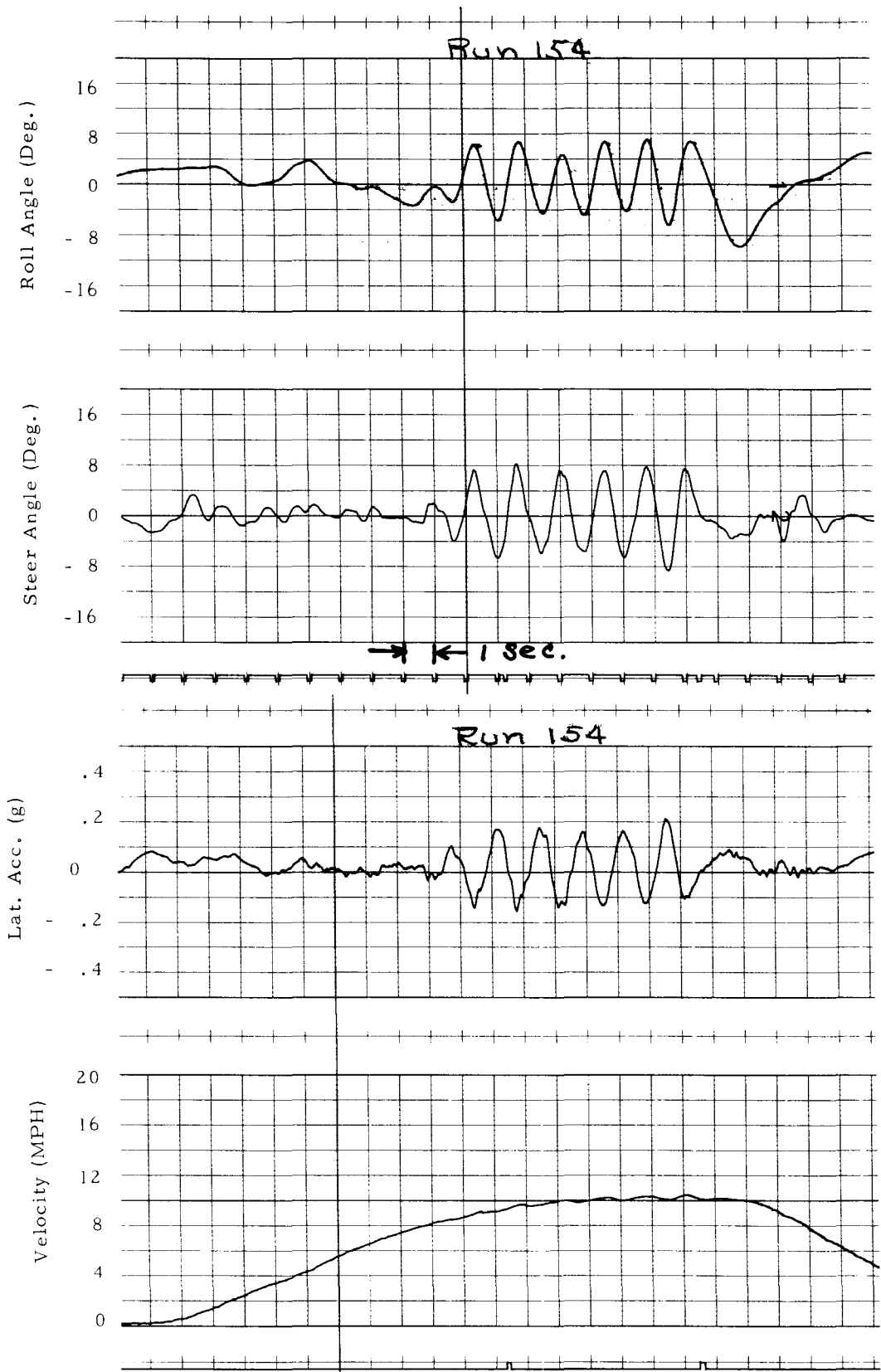

Figure II.4 Run 154, Narrow Slalom Course - Load on Rear Carrier

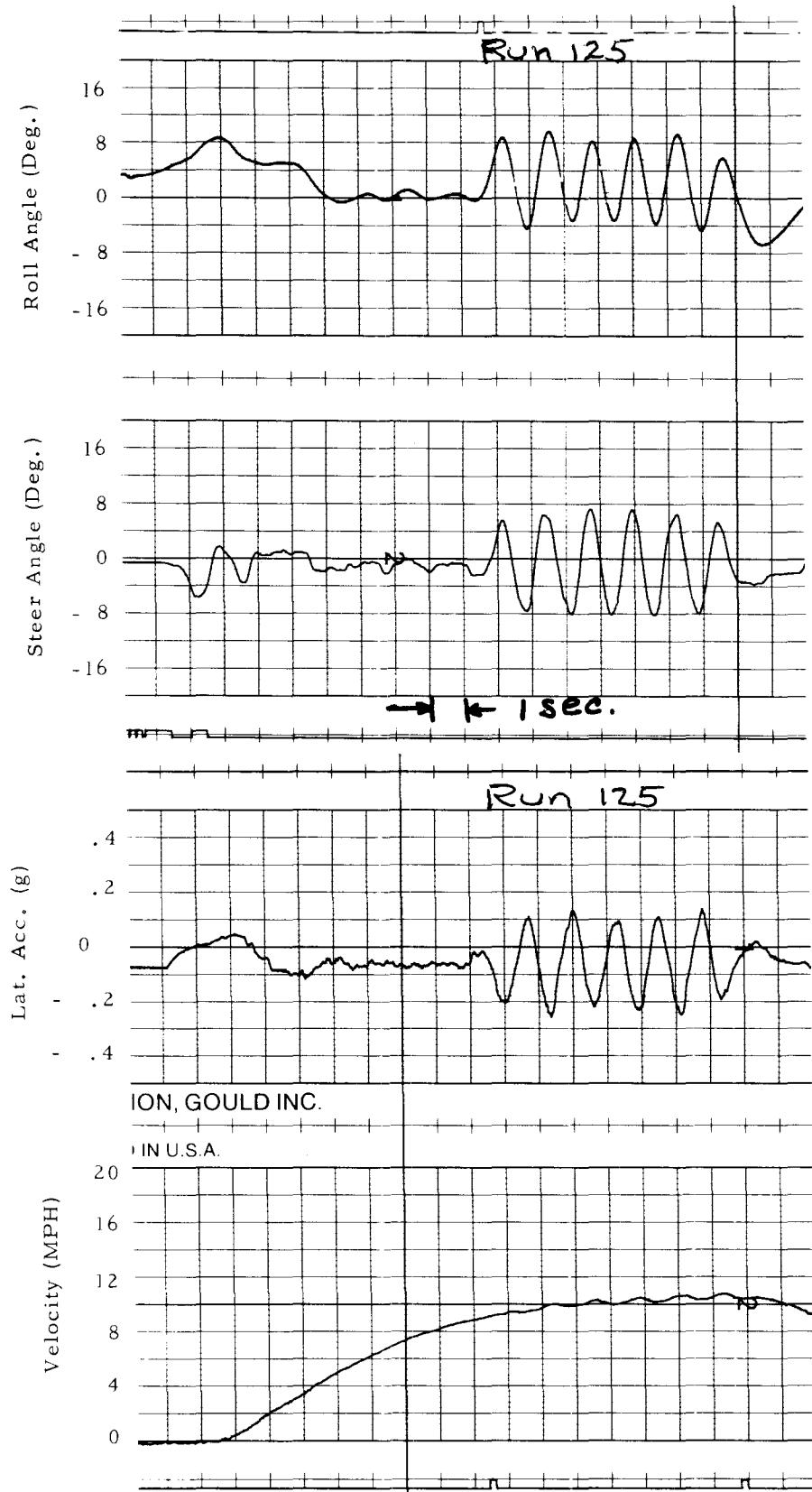

Figure II.5 Run 125, Narrow Slalom Course - Load in Rear Baskets

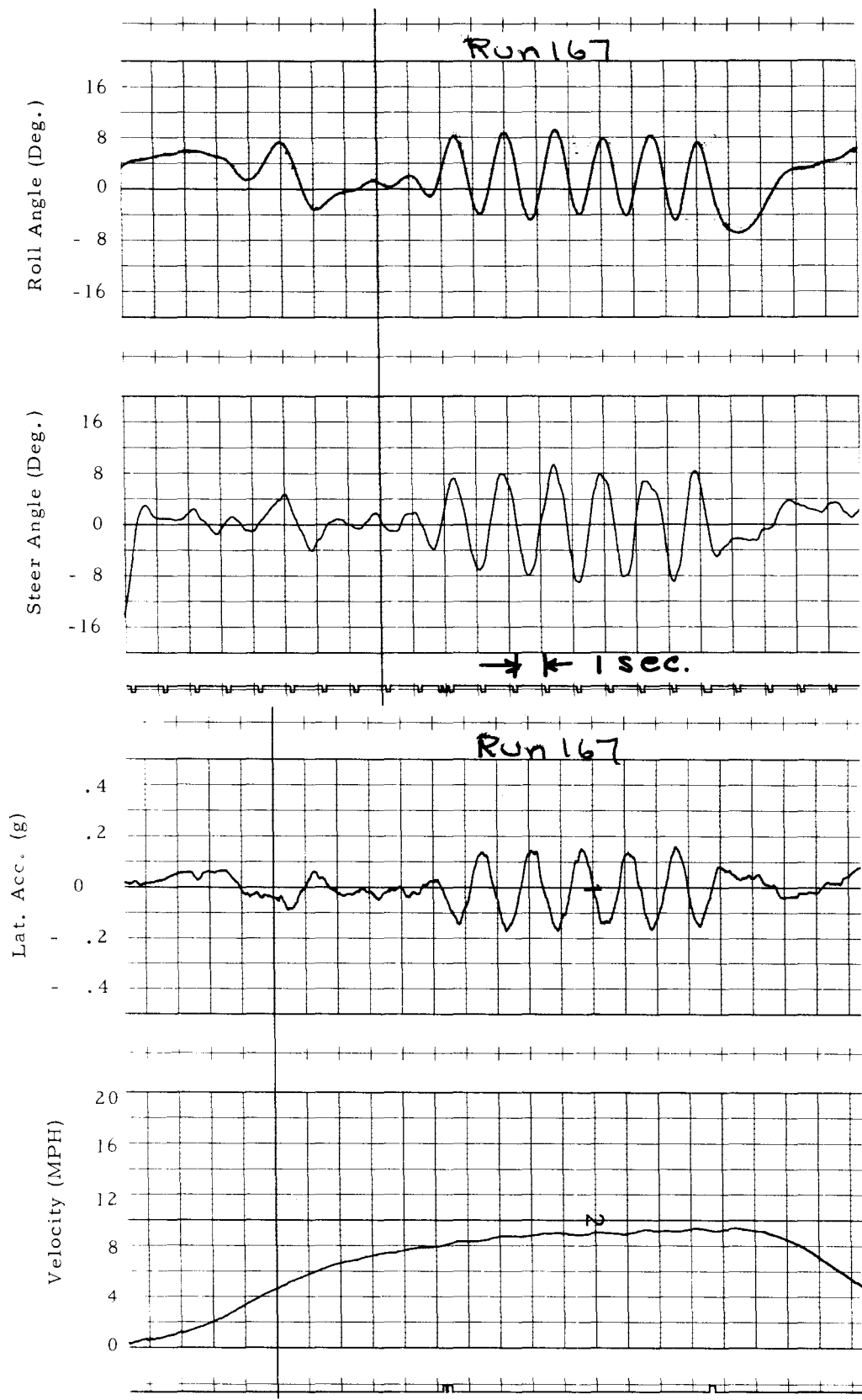

Figure II.6 Run 167, Narrow Slalom Course - Load on Front Carrier

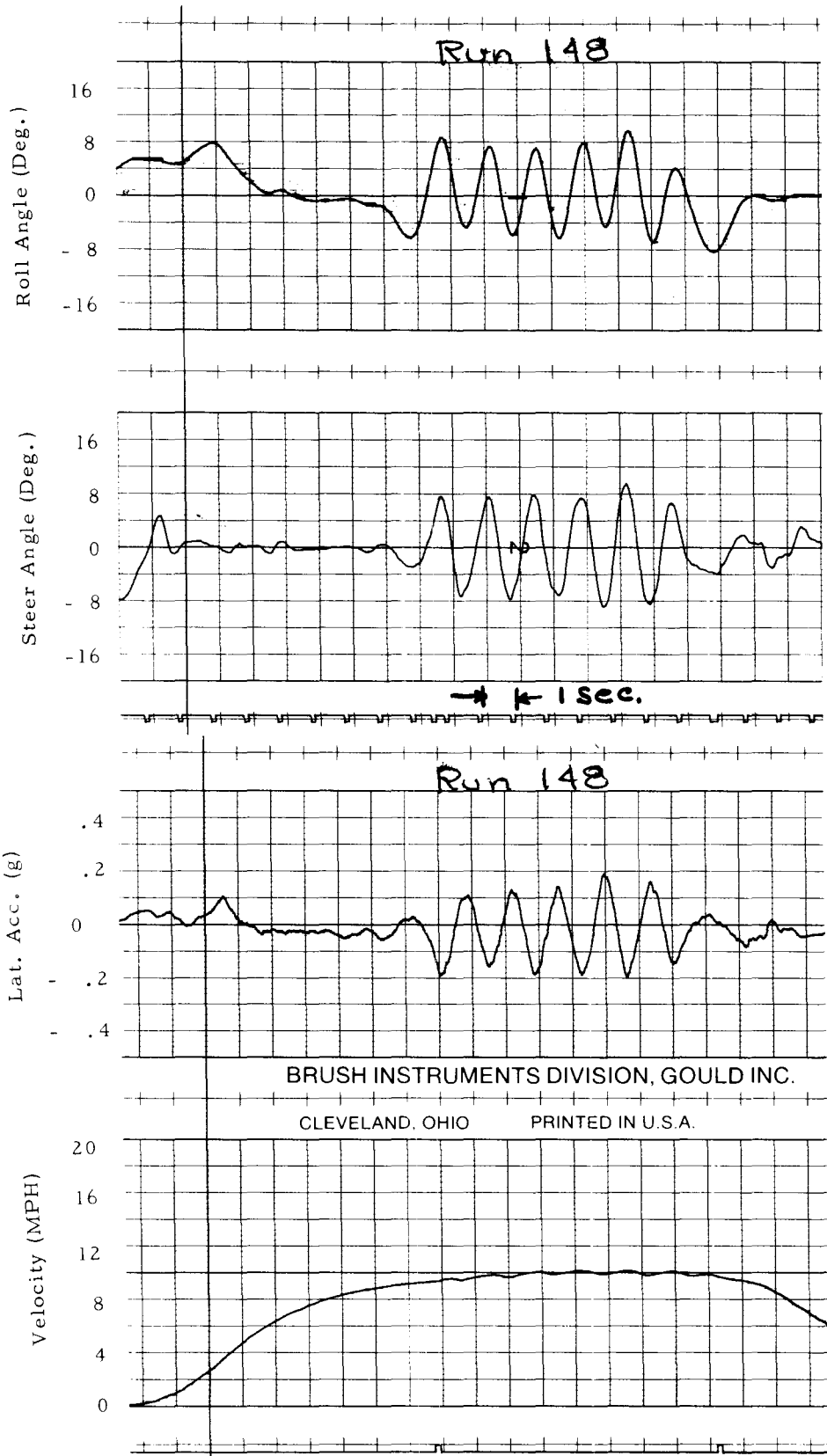

Figure II.7 Run 148, Narrow Slalom Course - Load on Front and Rear Carriers

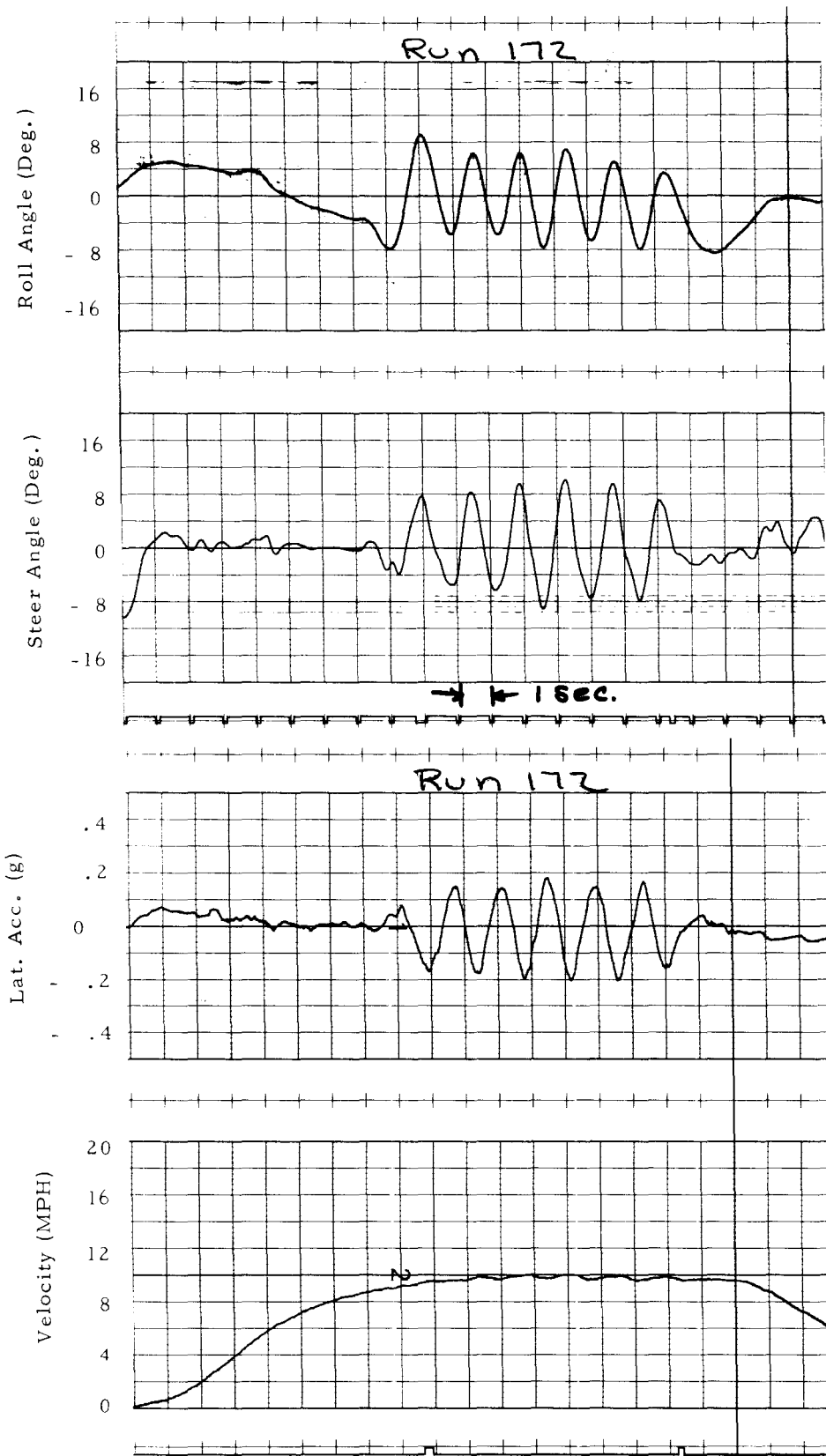

Figure II.8 Run 172, Narrow Slalom Course - Load in Rider's Backpack

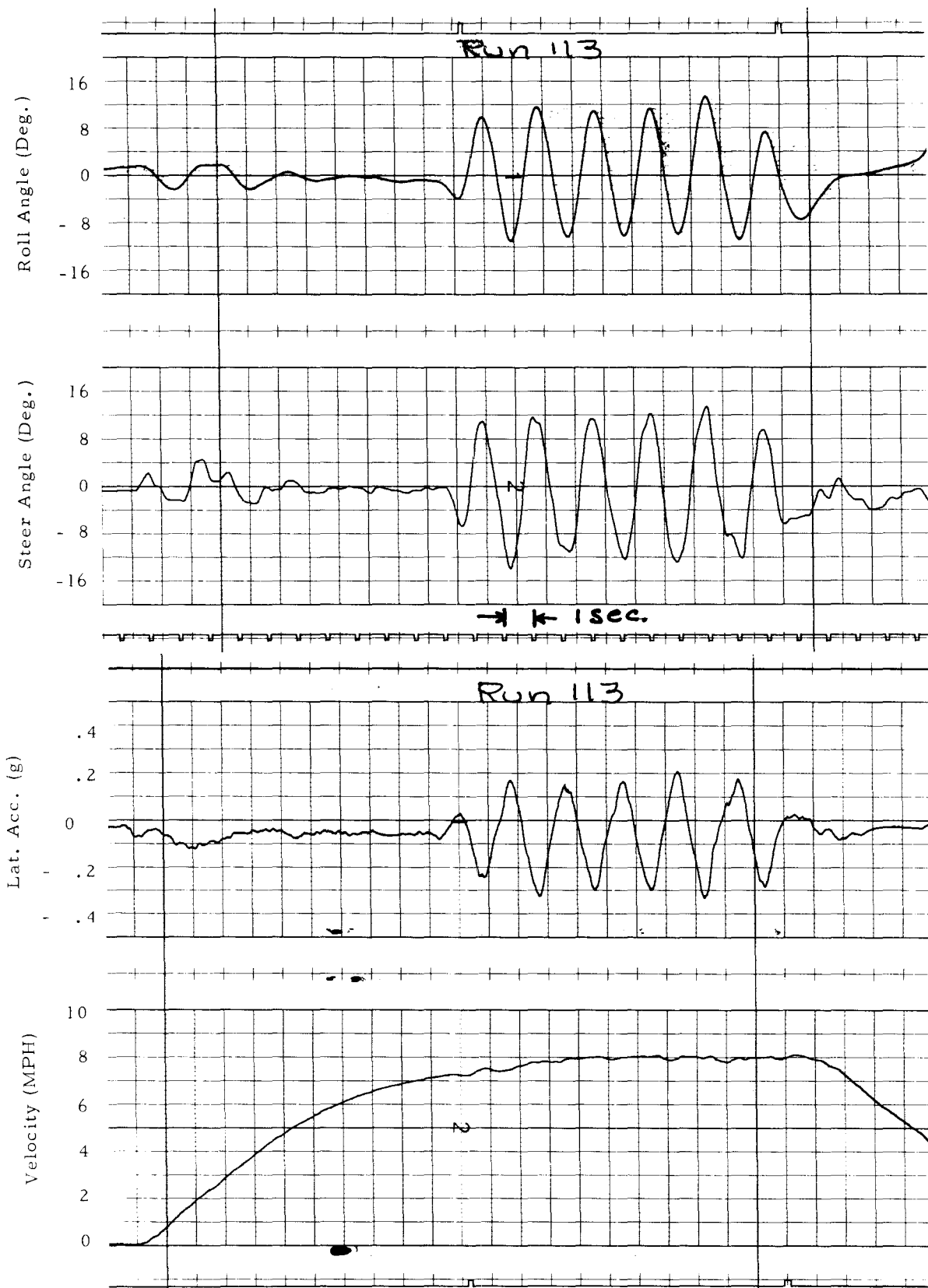

Figure II.9 Run 113, Wide Slalom Course - Standard Bicycle

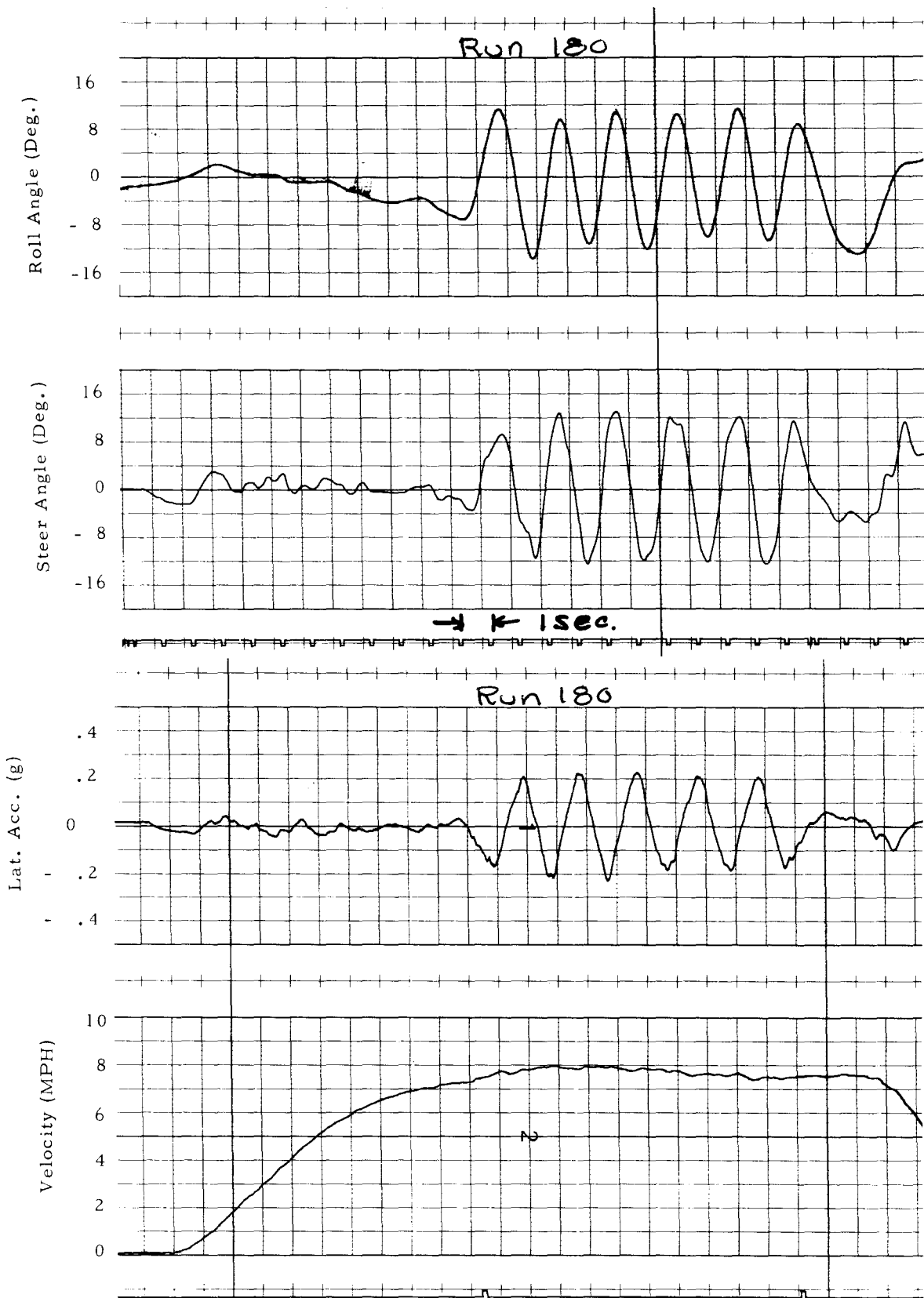

Figure II.10 Run 180, Wide Slalom Course - High Wheel Spin Inertia

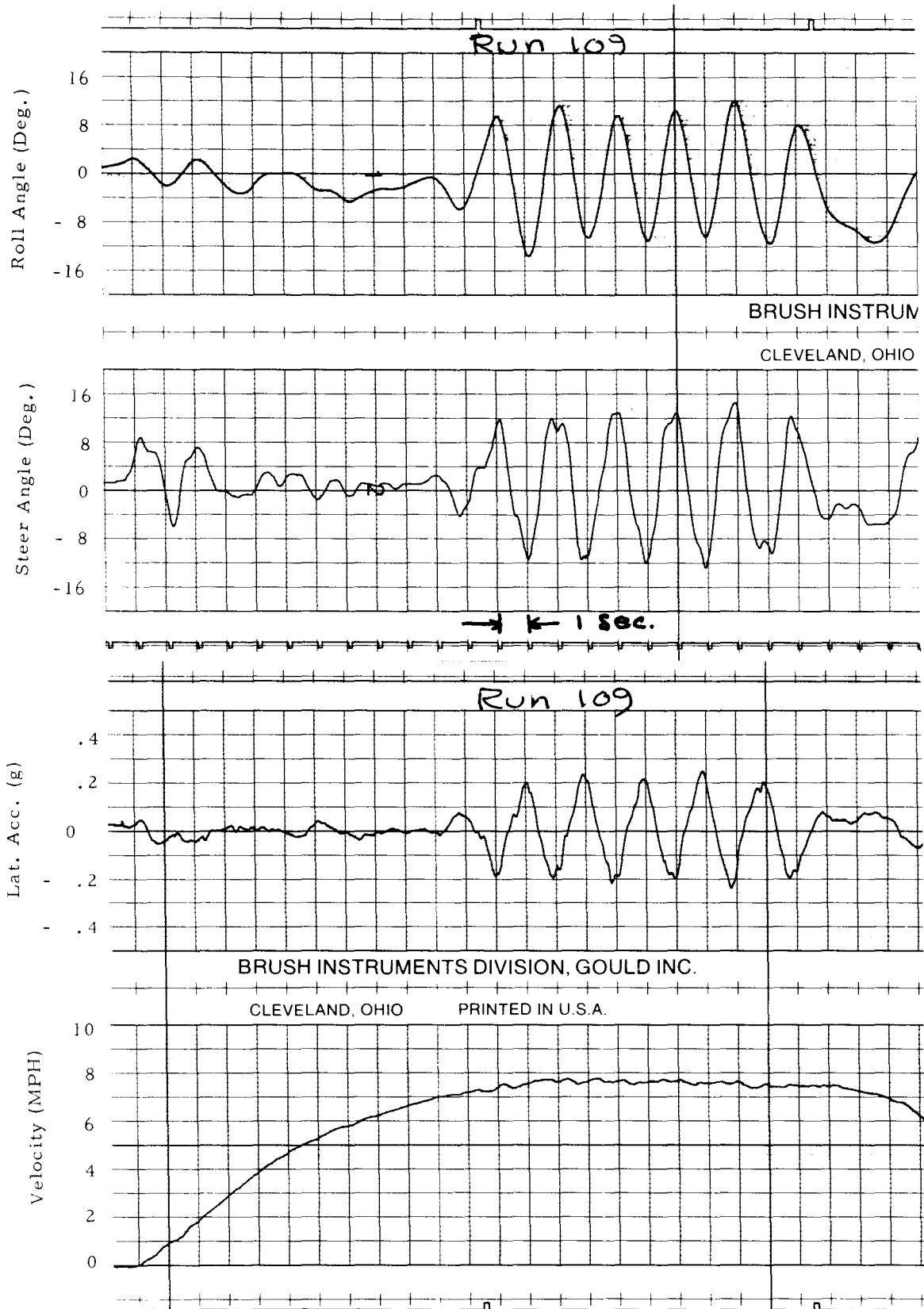

Figure II. 11 Run 109, Wide Slalom Course - Low Front Tire Pressure

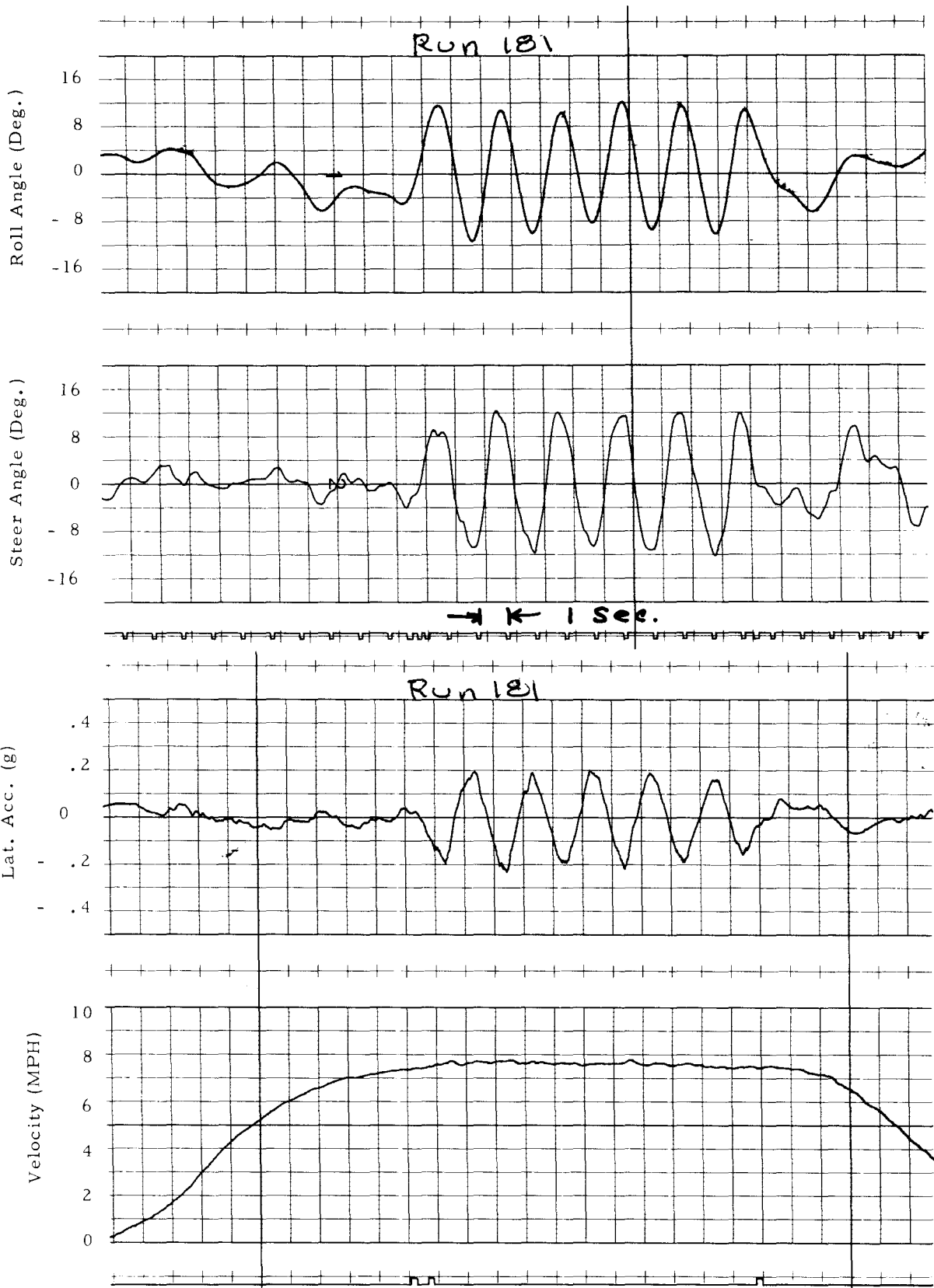

Figure II.12 Run 181, Wide Slalom Course - Low Rear Tire Pressure

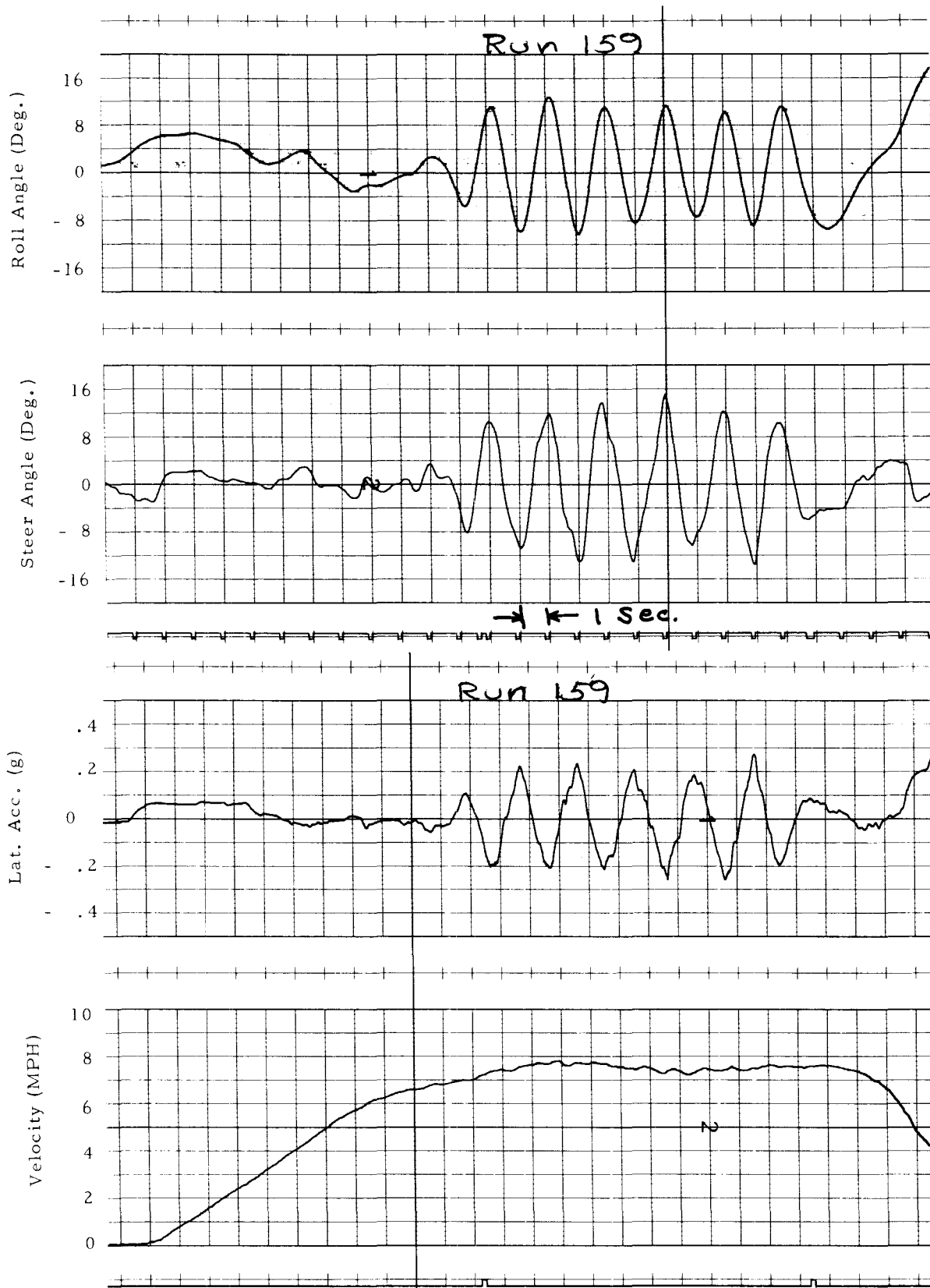

Figure II.13 Run 159, Wide Slalom Course - Load on Rear Carrier

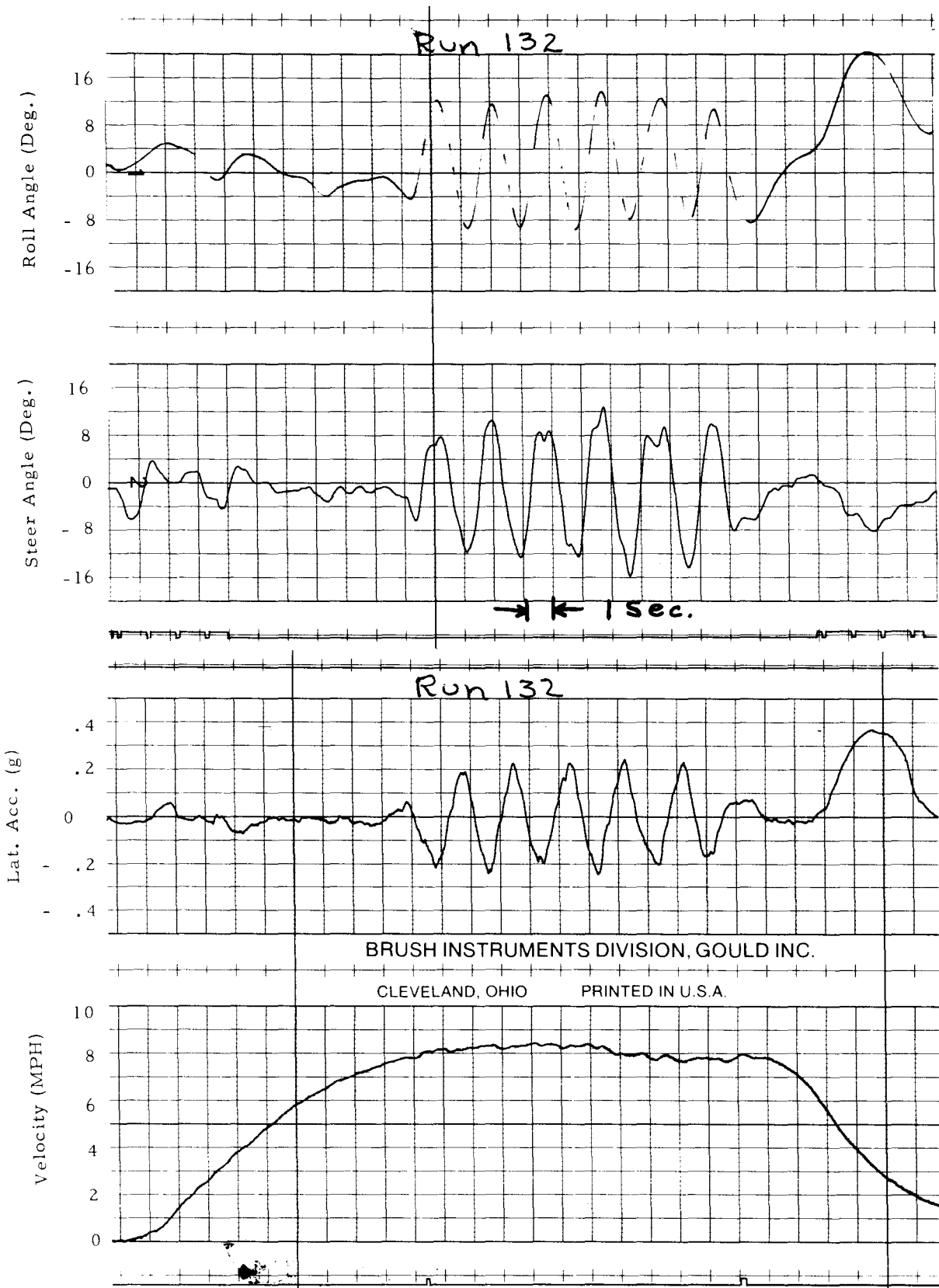

Figure II.14 Run 132, Wide Slalom Course - Load in Rear Baskets

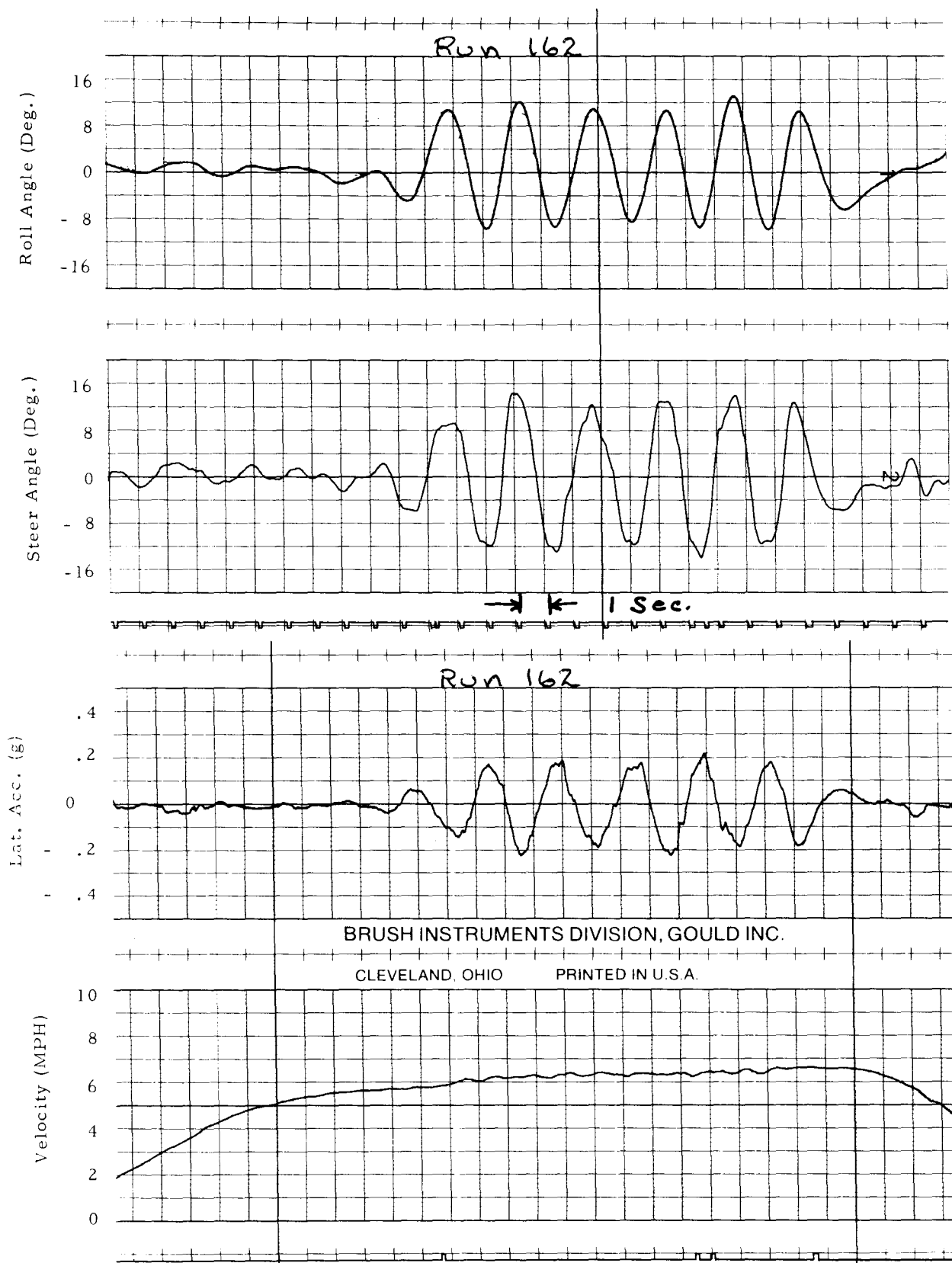

Figure II. 15 Run 162, Wide Slalom Course - Load on Front Carrier

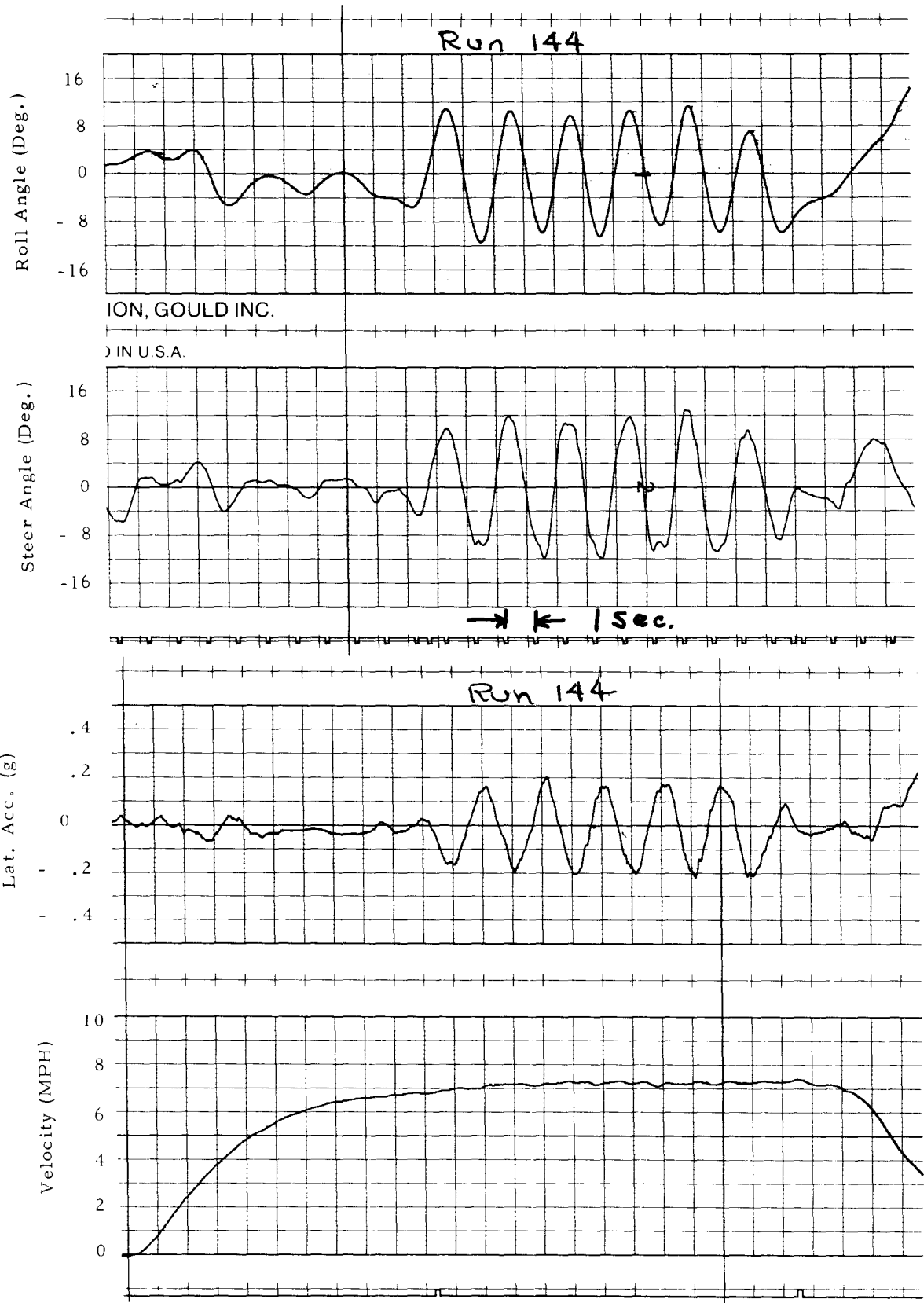

Figure II. 16 Run 144, Wide Slalom Course - Load on Front and Rear Carriers

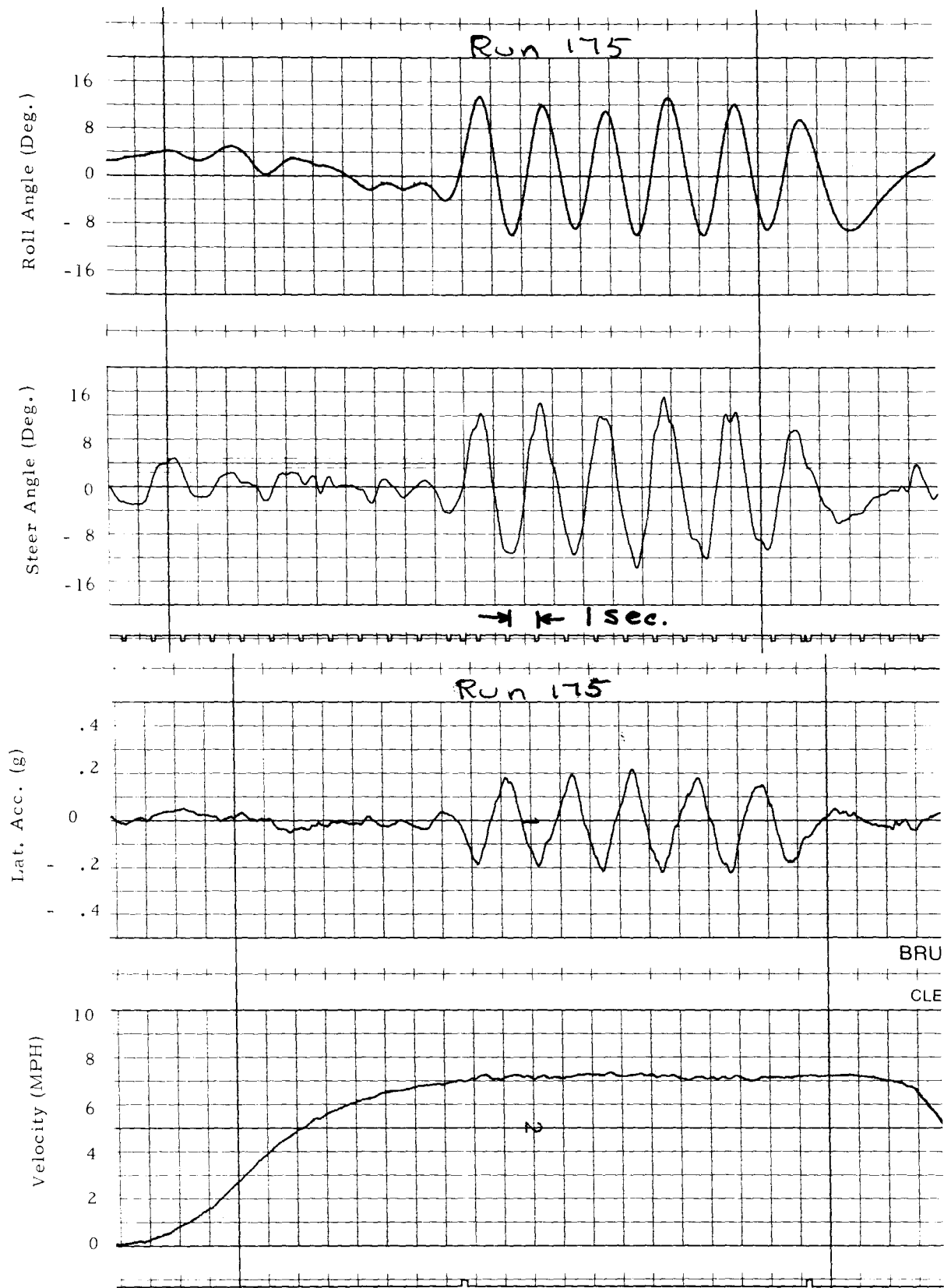

Figure II. 17 Run 175, Wide Slalom Course - Load in Rider's Backpack

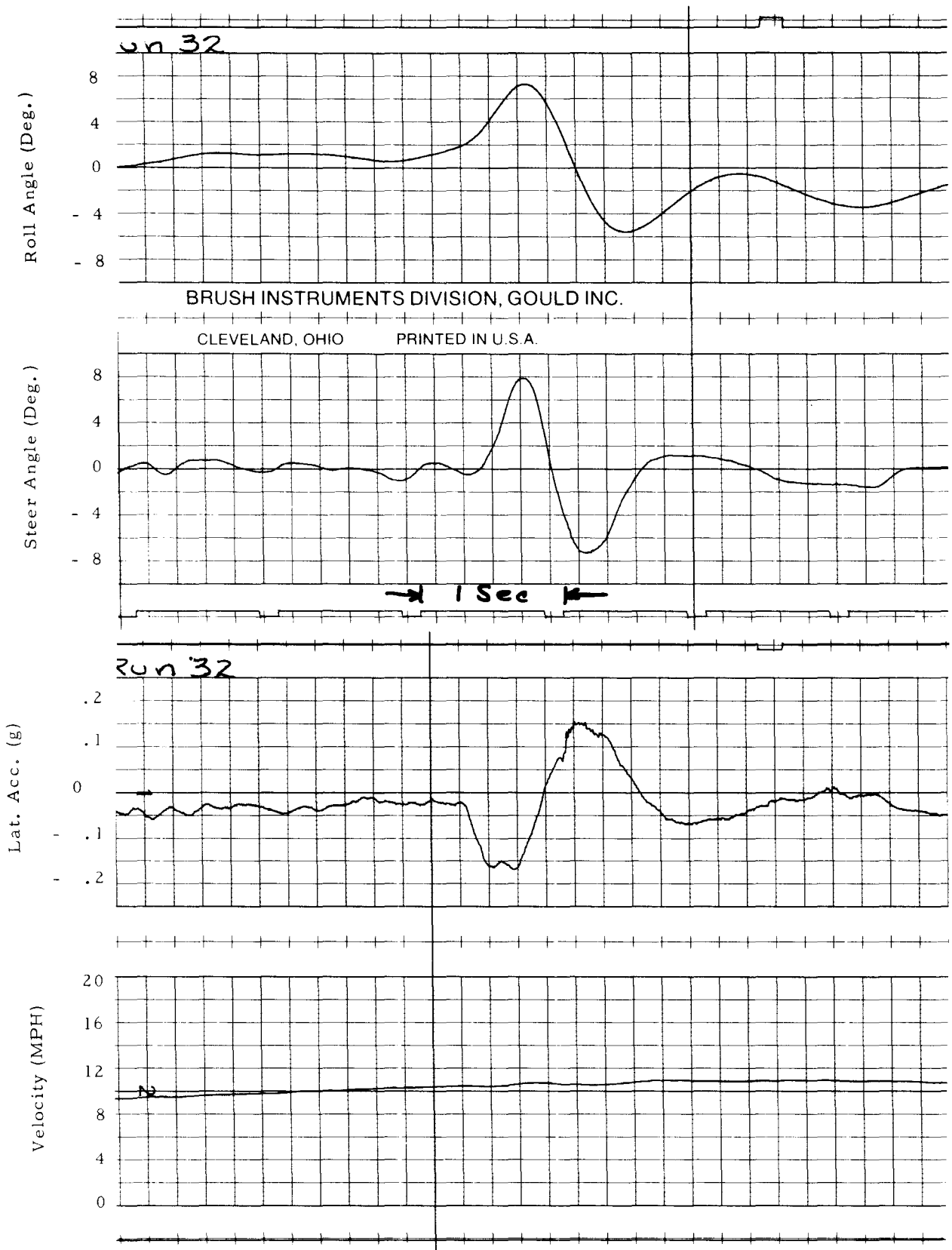

Figure II. 18 Run 32, Obstacle Avoidance - Standard Bicycle

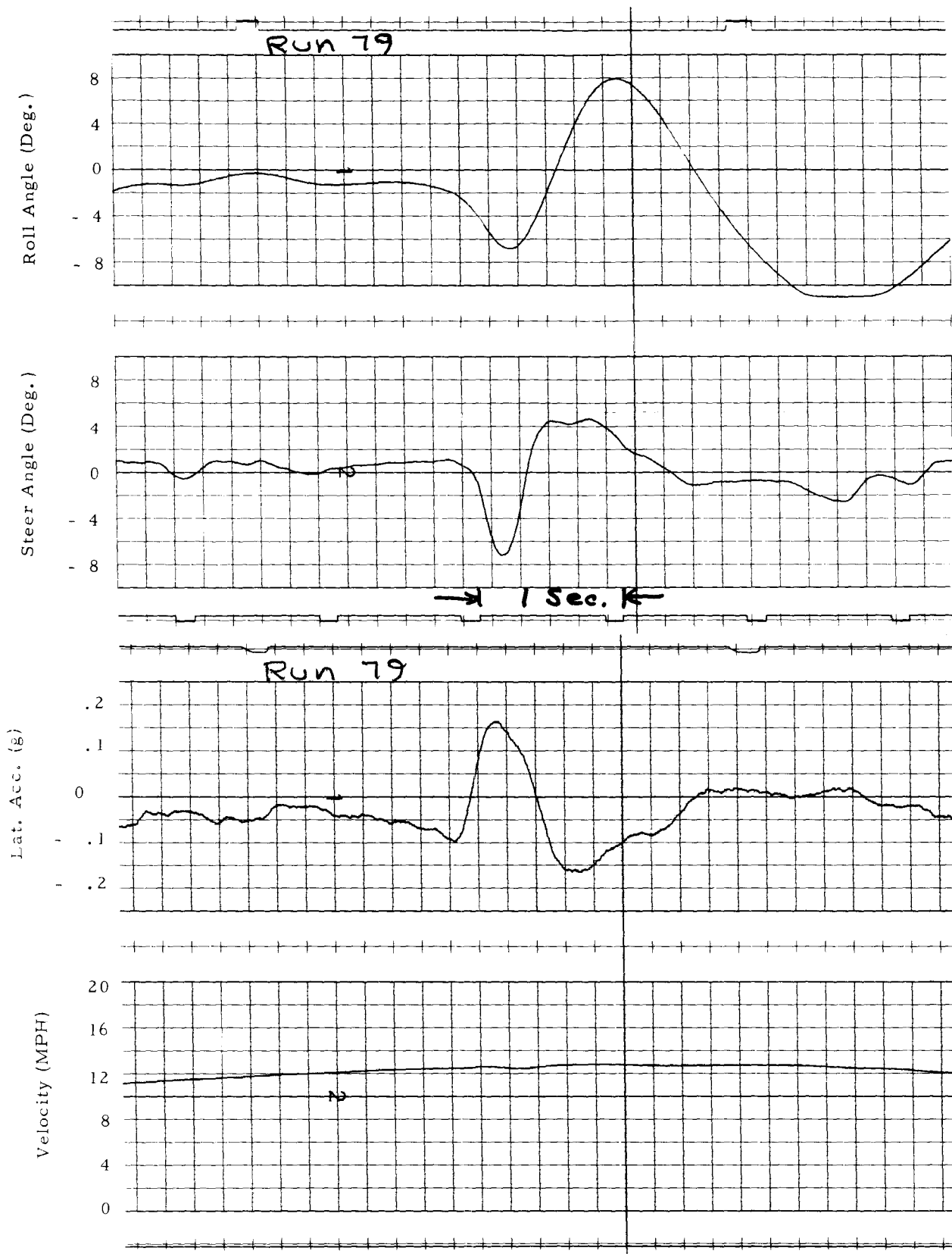

Figure II.19 Run 79, Obstacle Avoidance - High Wheel Spin Inertia

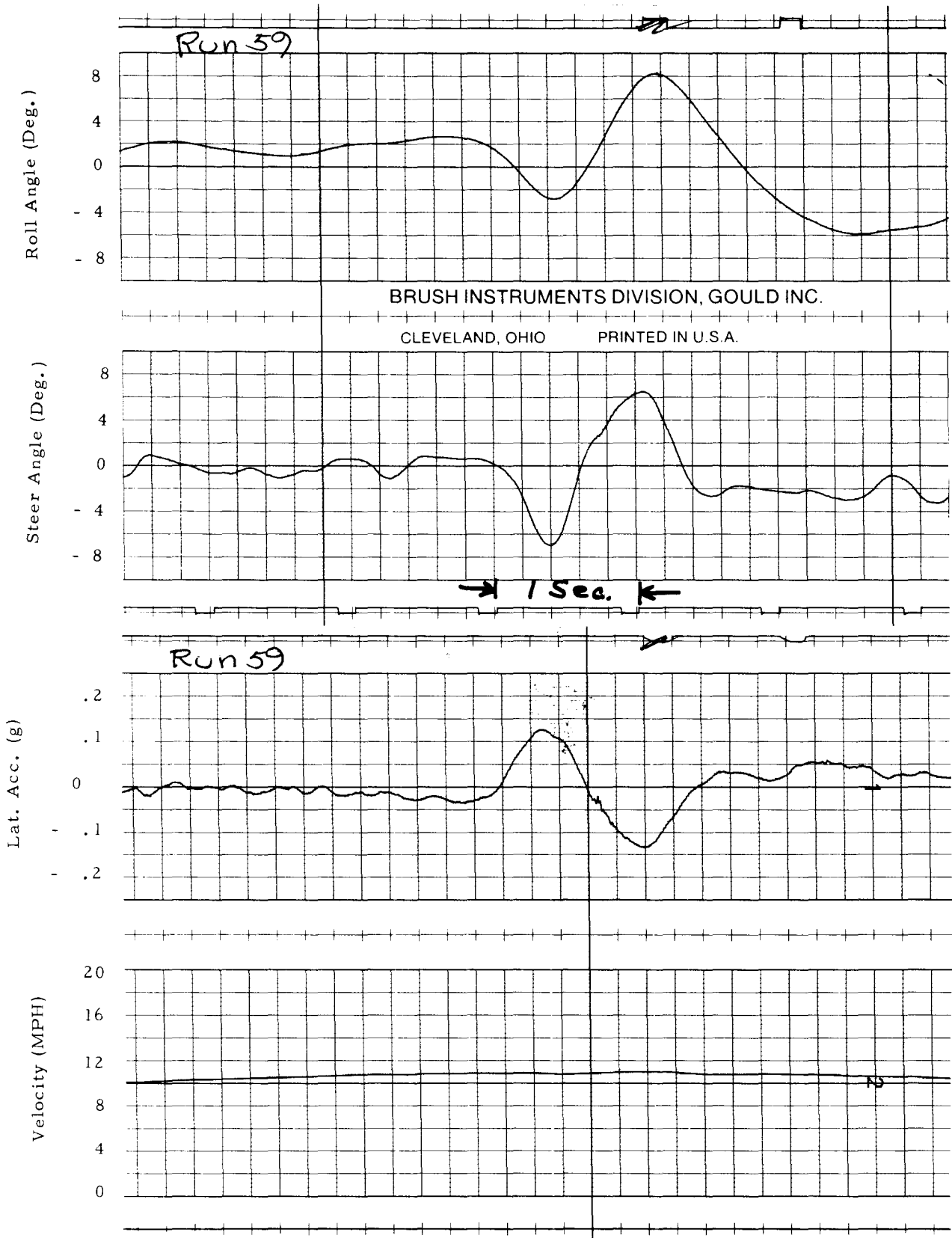
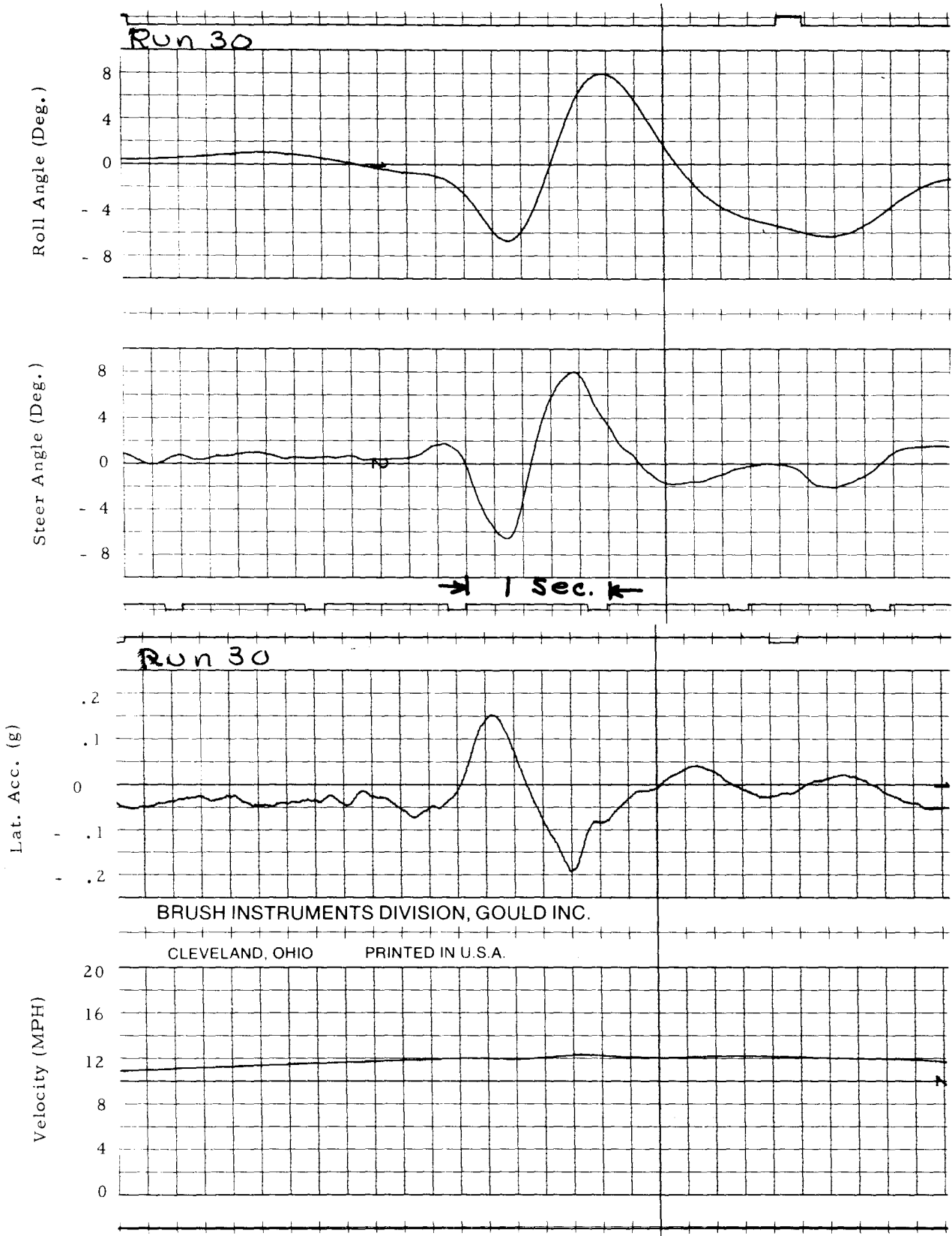

Figure II.20 Run 59, Obstacle Avoidance - Low Front Tire Pressure



BRUSH INSTRUMENTS DIVISION, GOULD INC.

CLEVELAND, OHIO

PRINTED IN U.S.A.

Figure II.21 Run 30a, Obstacle Avoidance - Low Rear Tire Pressure

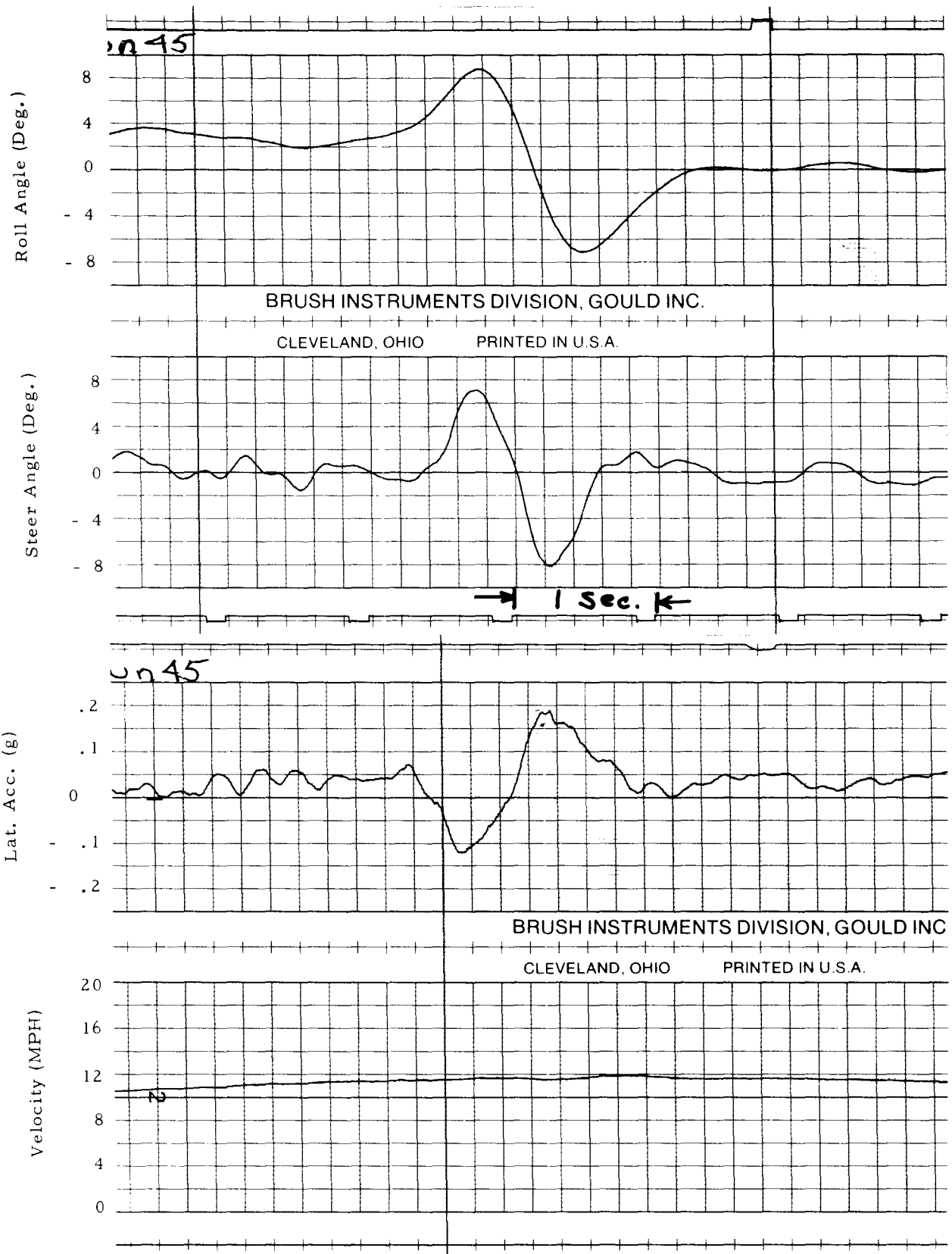

Figure II.22 Run 45, Obstacle Avoidance - Load on Rear Carrier

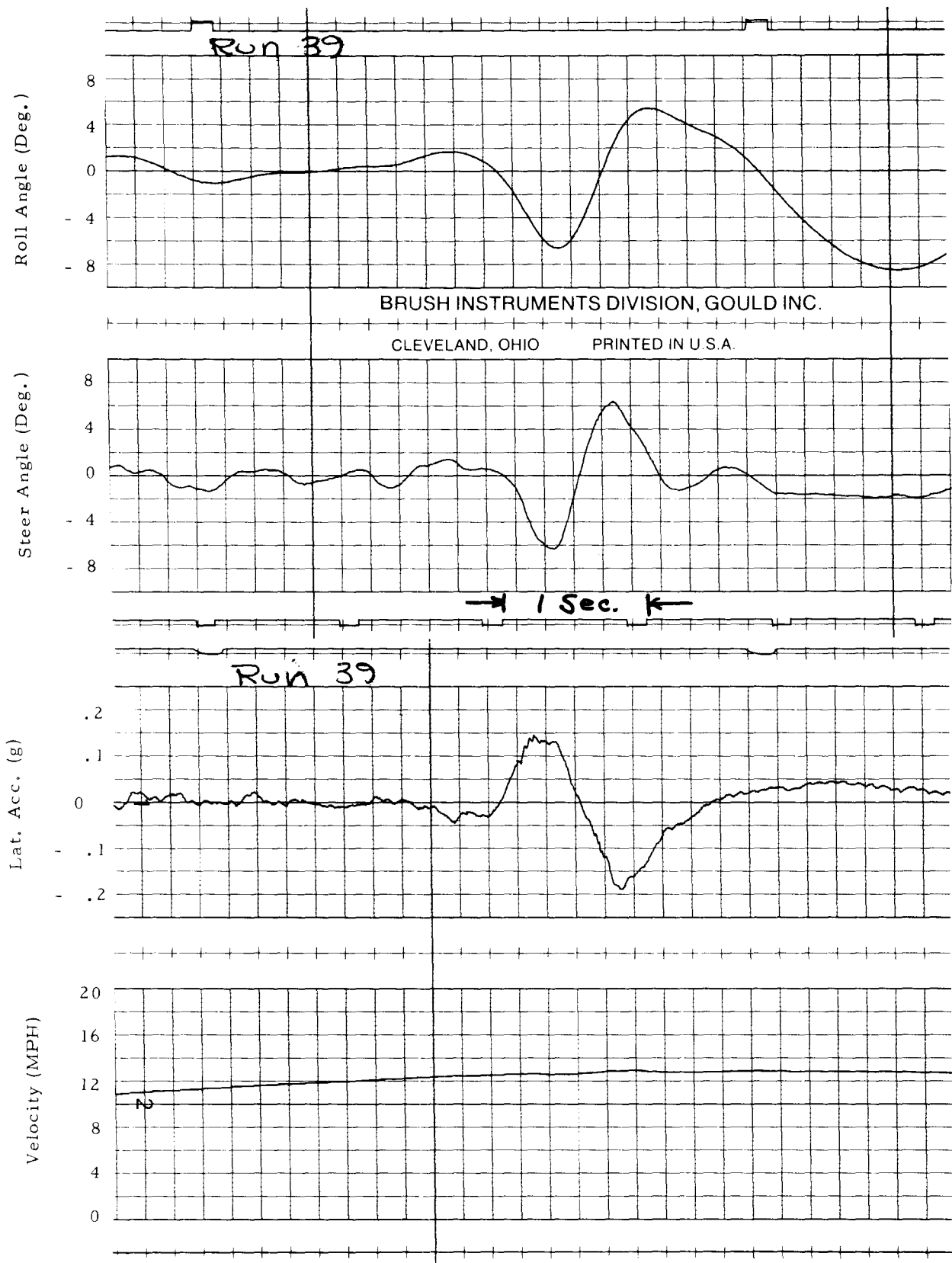

Figure II.23 Run 39, Obstacle Avoidance - Load in Rear Baskets

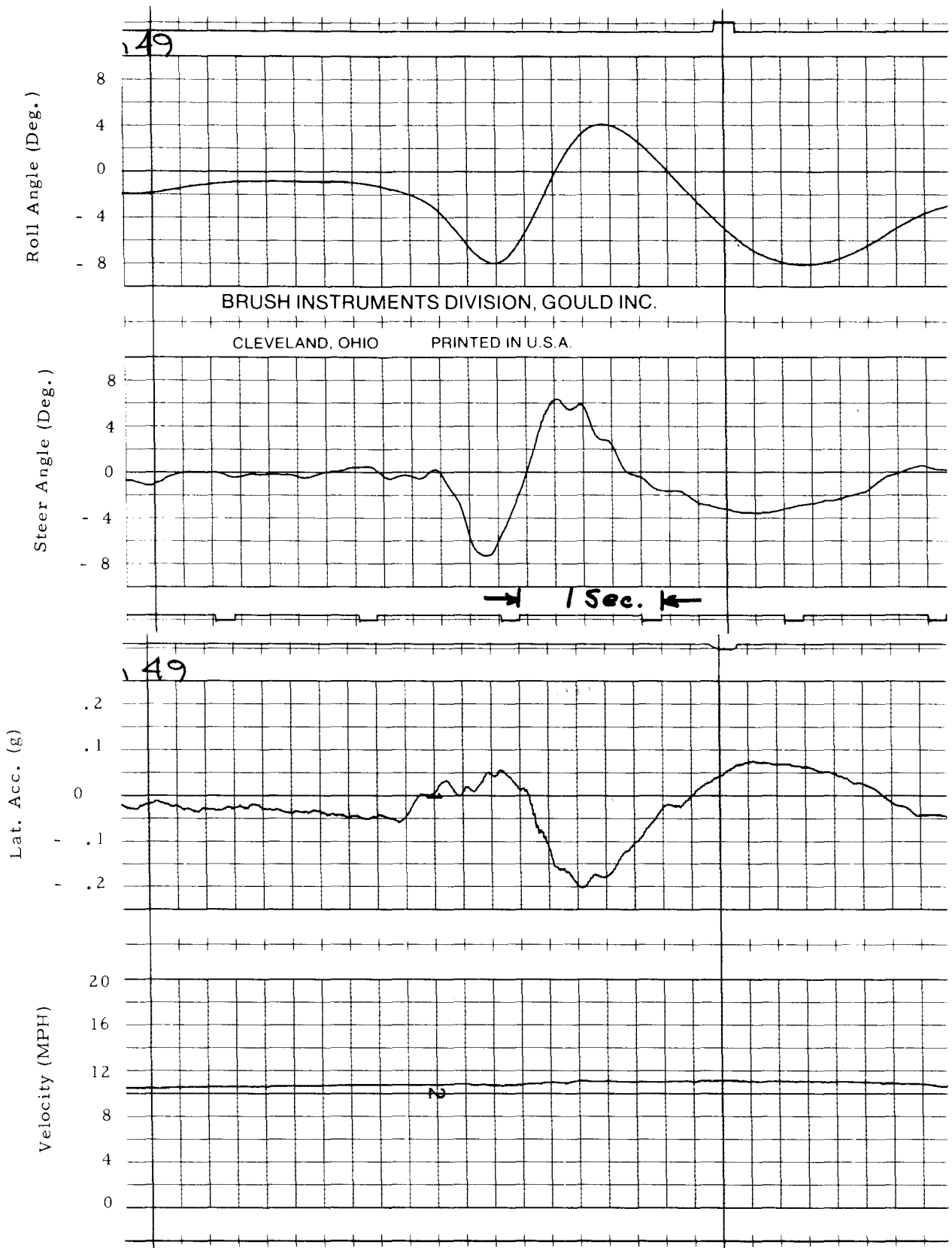
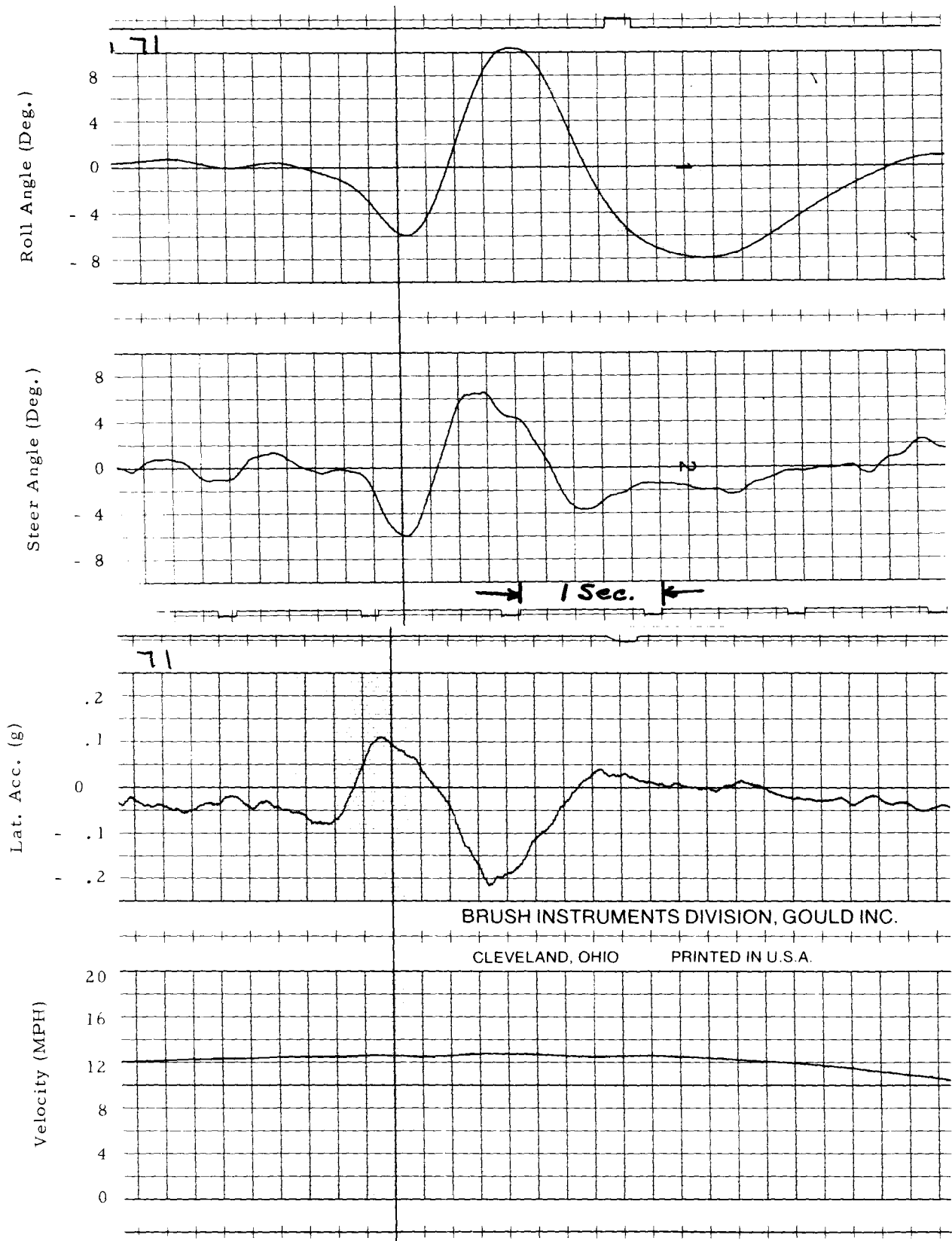

Figure II.24 Run 49, Obstacle Avoidance - Load on Front Carrier



BRUSH INSTRUMENTS DIVISION, GOULD INC.

CLEVELAND, OHIO PRINTED IN U.S.A.

Figure II.25 Run 71, Obstacle Avoidance - Load on Front and Rear Carriers

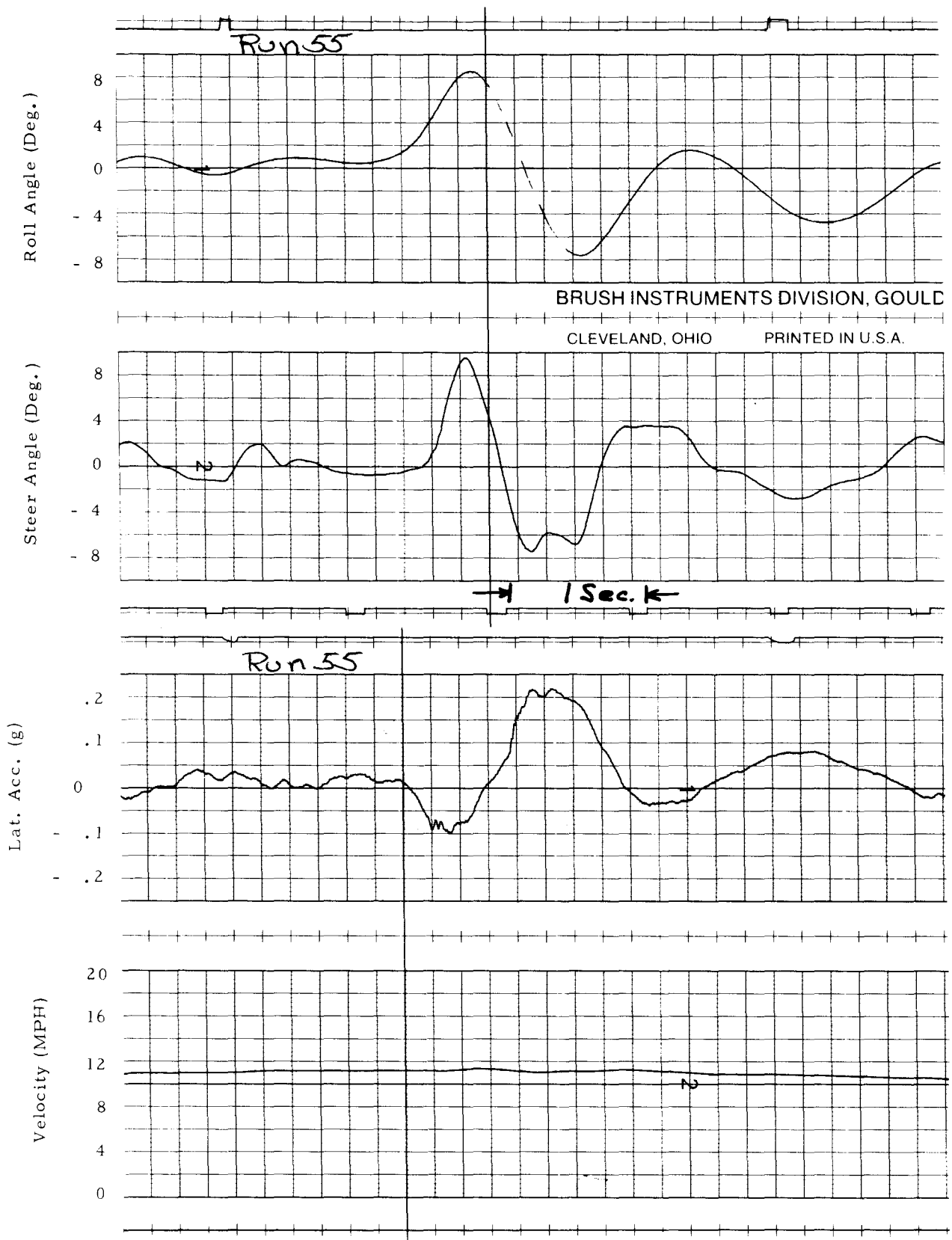

BRUSH INSTRUMENTS DIVISION, GOULD
 CLEVELAND, OHIO PRINTED IN U.S.A.

Figure II.26 Run 55, Obstacle Avoidance - Load in Rider's Backpack

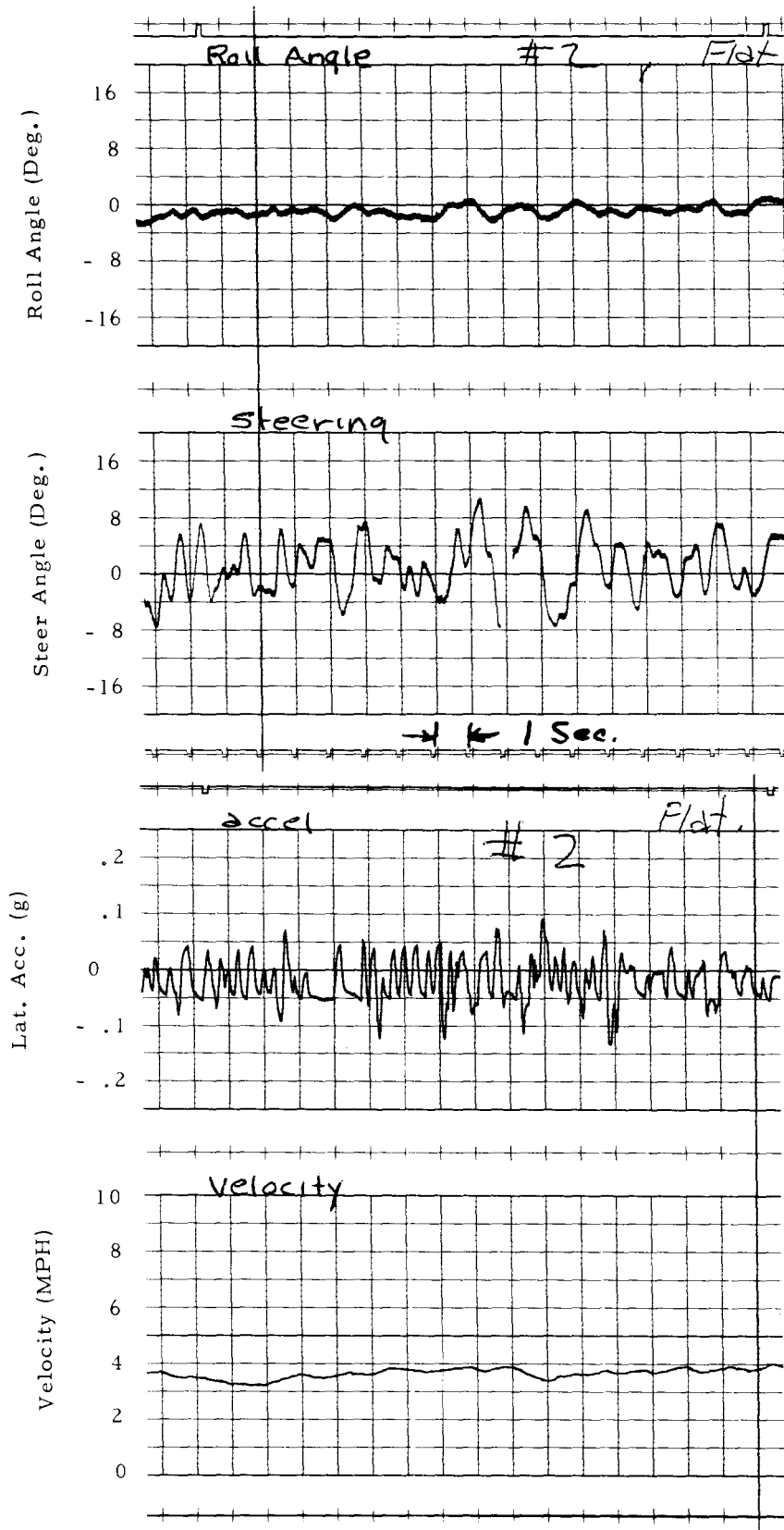

Figure II.27 Run 2, Low Speed Stability - Standard Bicycle

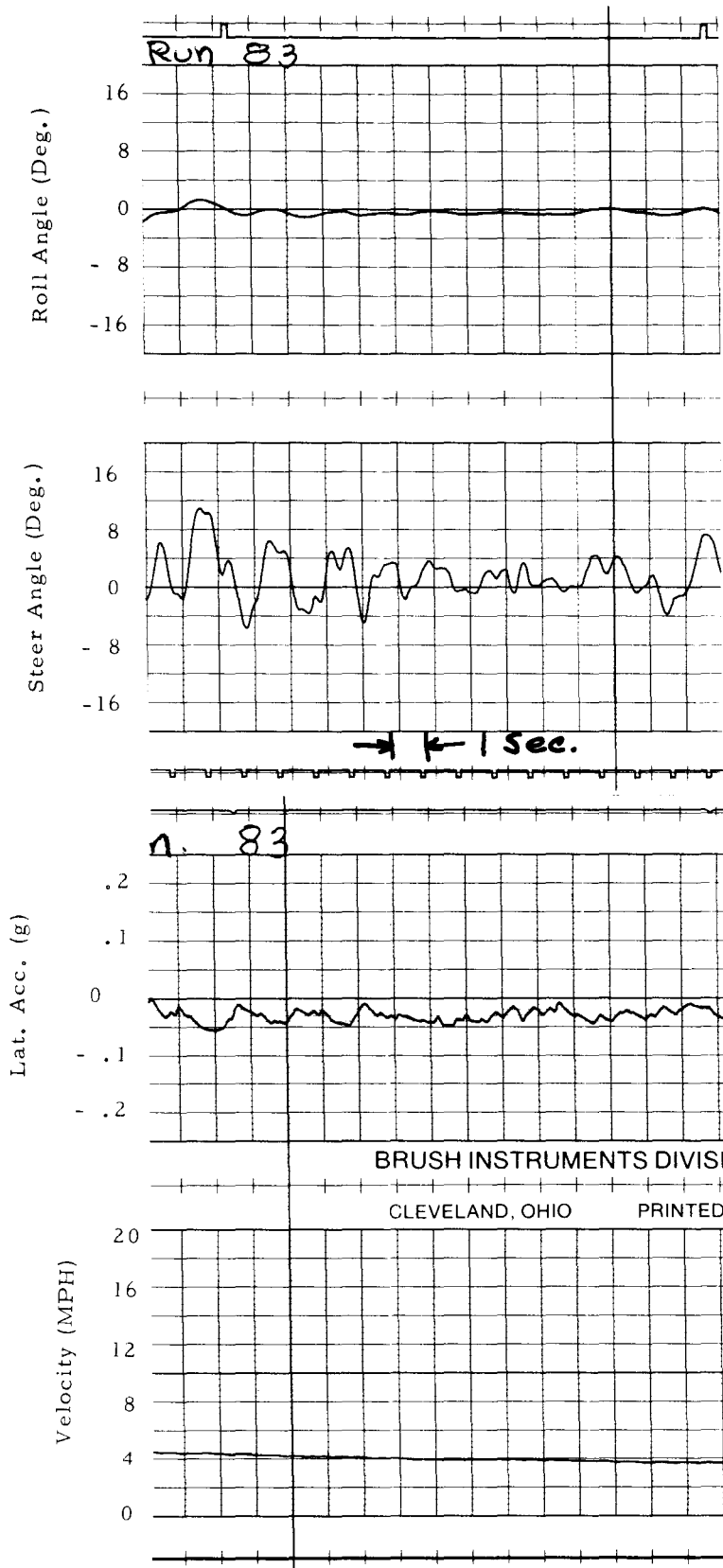

Figure II.28 Run 83, Low Speed Stability - High Wheel Spin Inertia

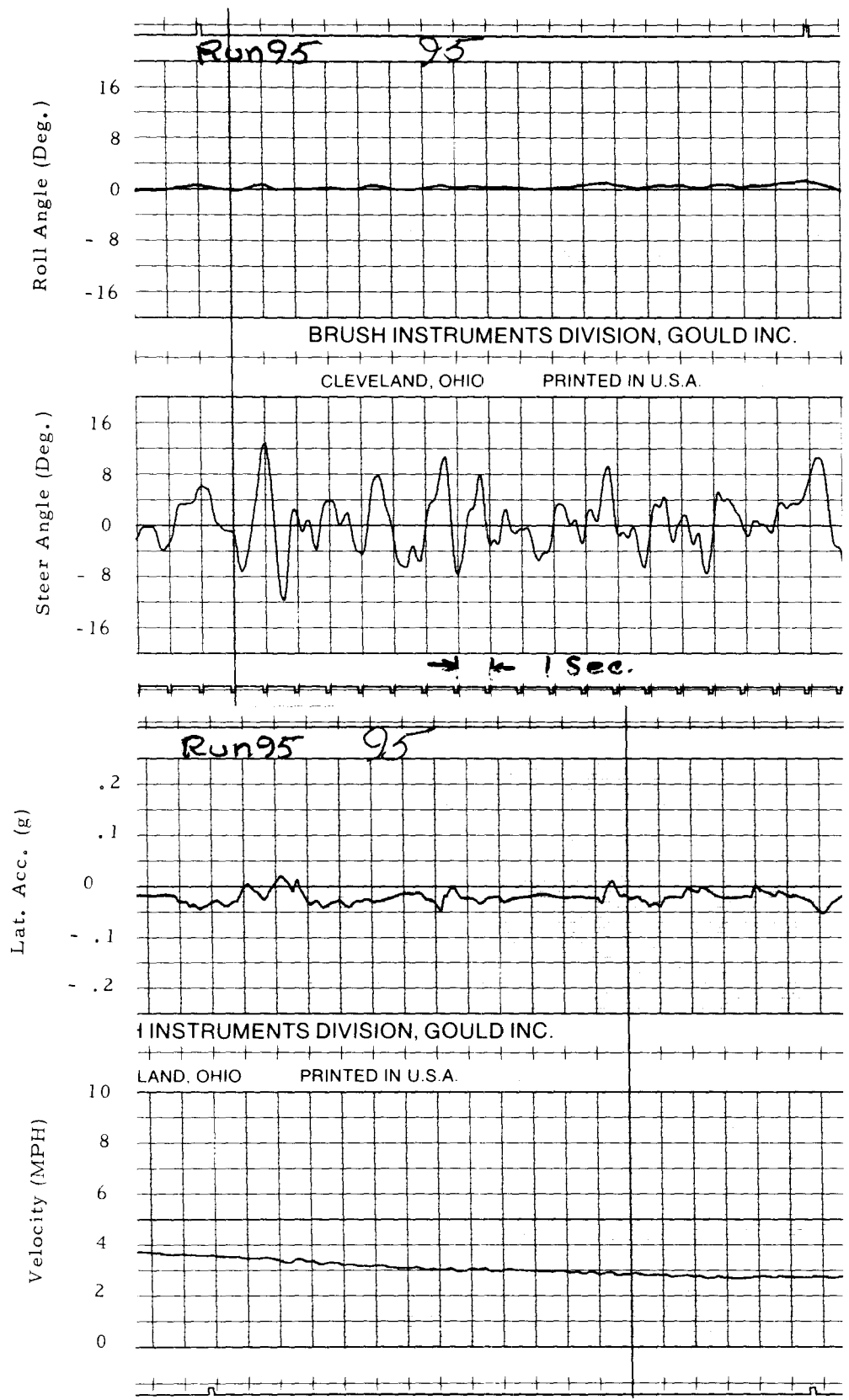

Figure II.29 Run 95, Low Speed Stability - Low Front Tire Pressure

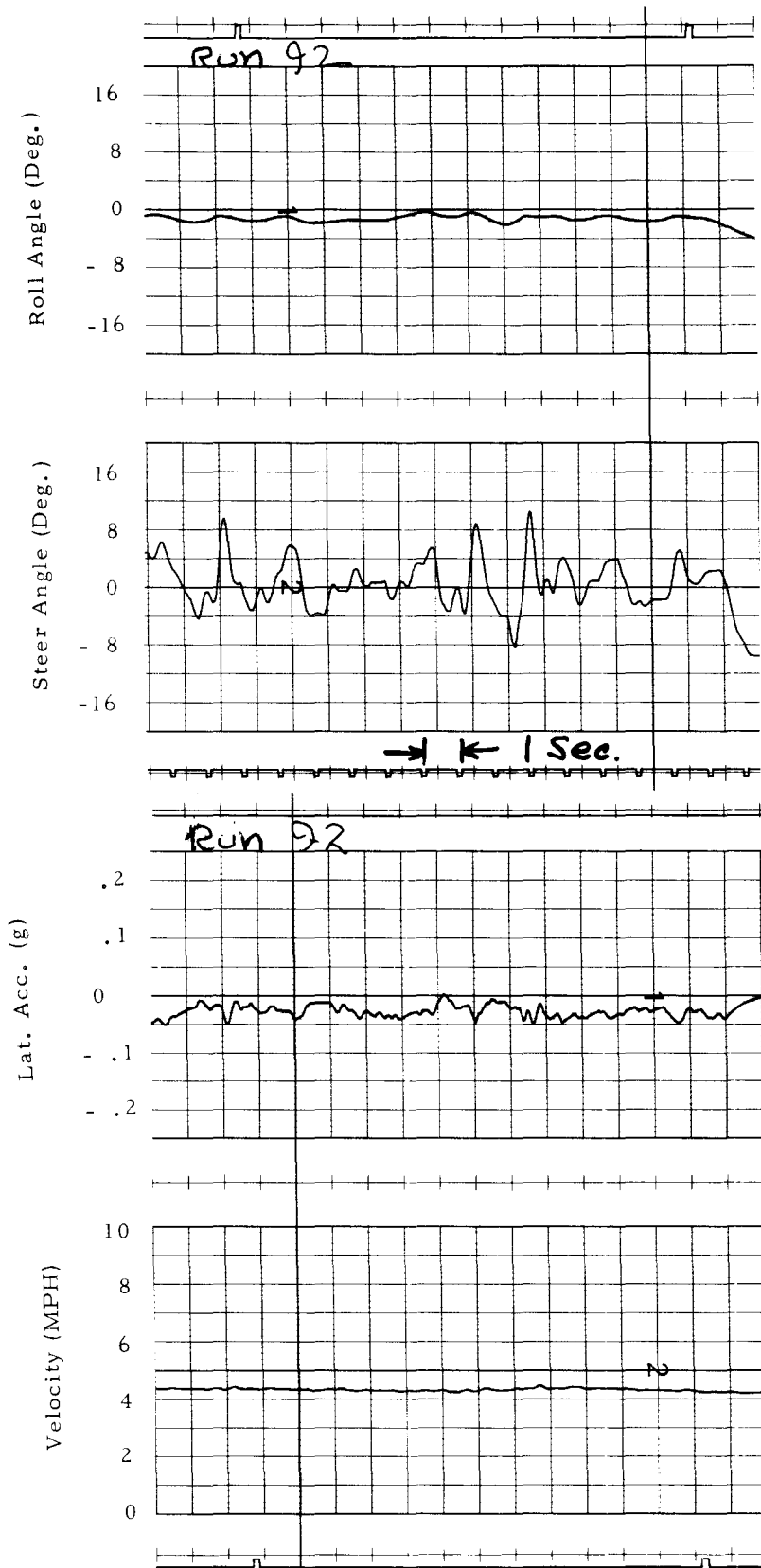

Figure II.30 Run 92, Low Speed Stability - Low Rear Tire Pressure

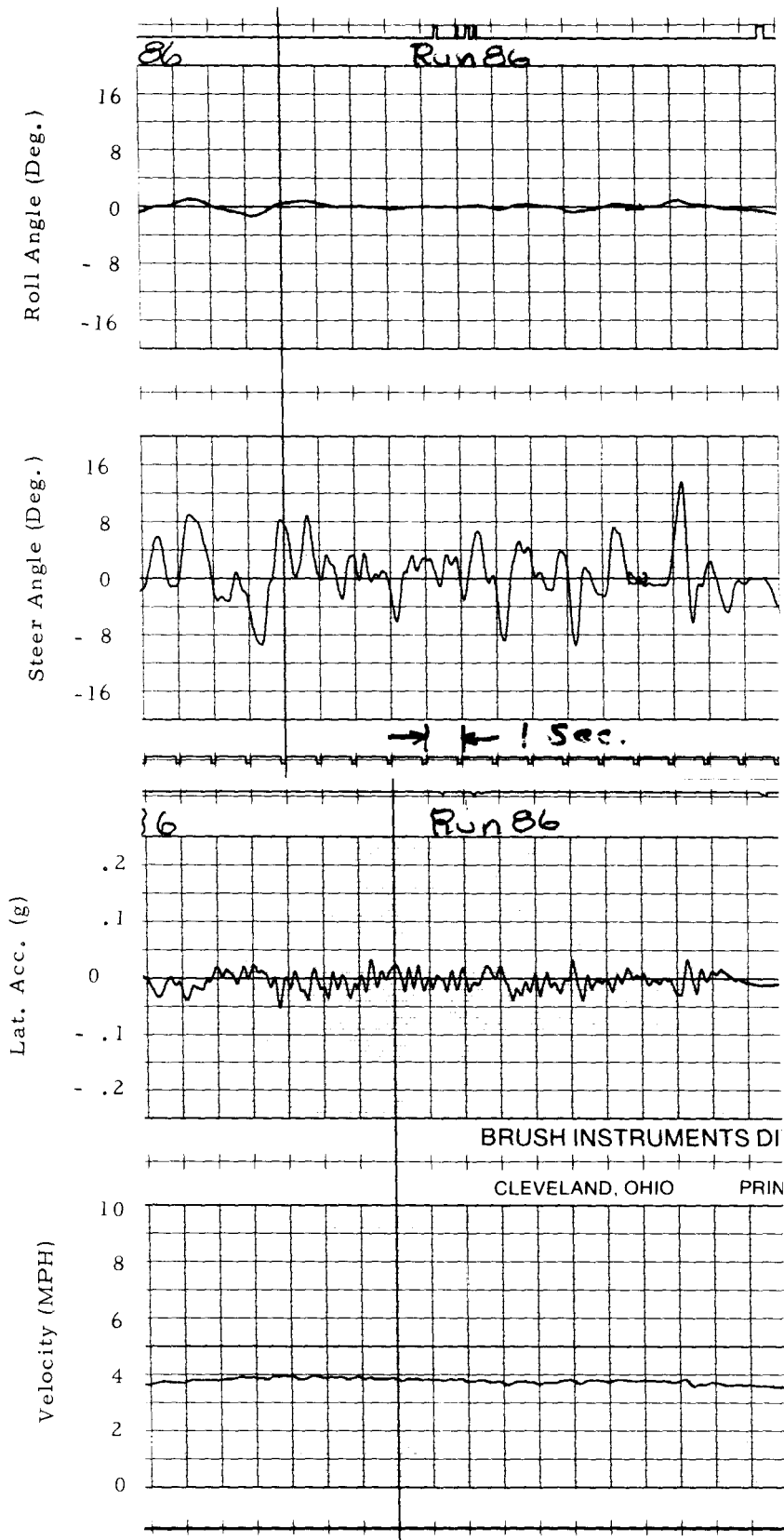

Figure II.31 Run 86, Low Rear Tire Pressure - Load on Rear Carrier

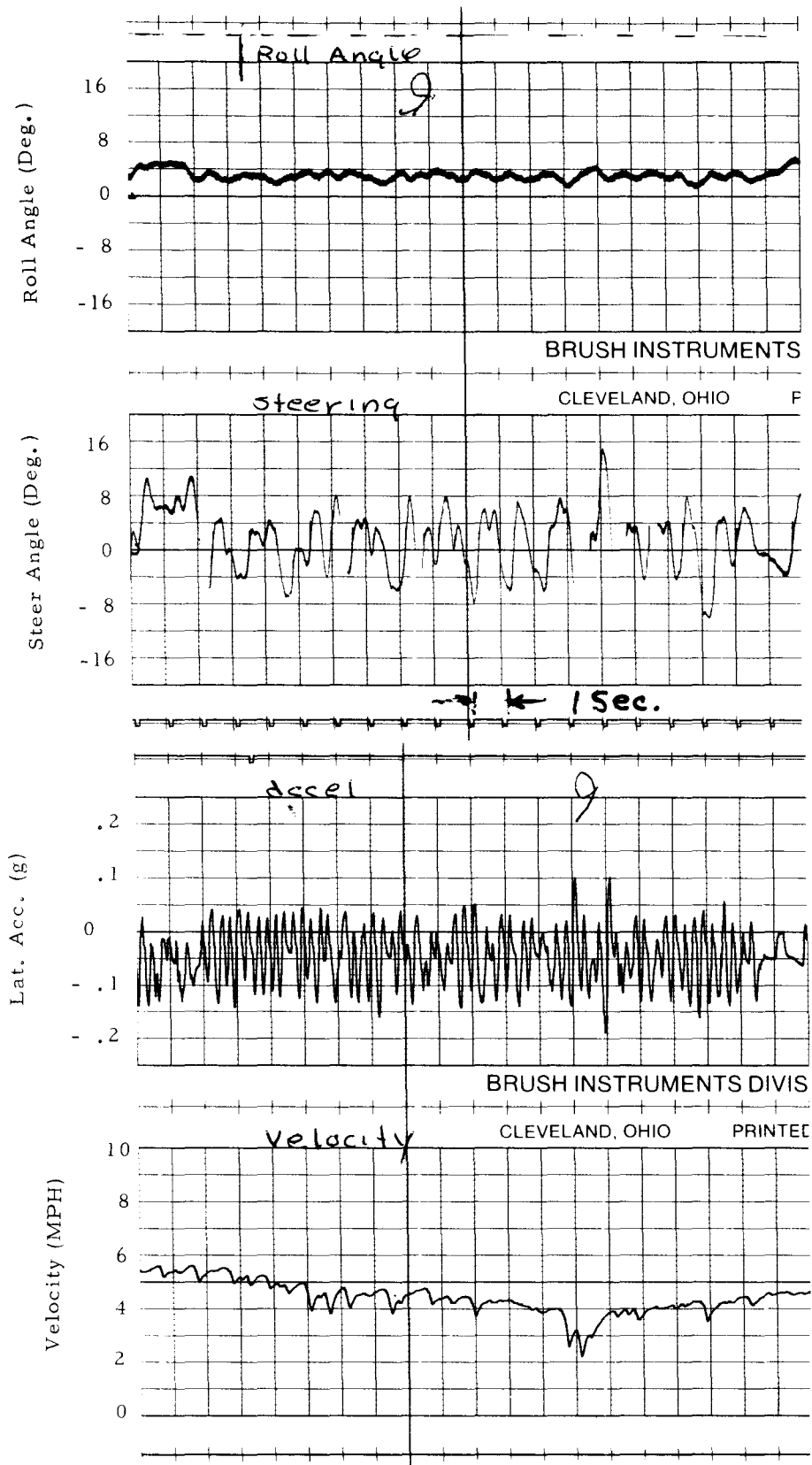

Figure II.32 Run 9, Low Speed Stability - Load in Rear Baskets

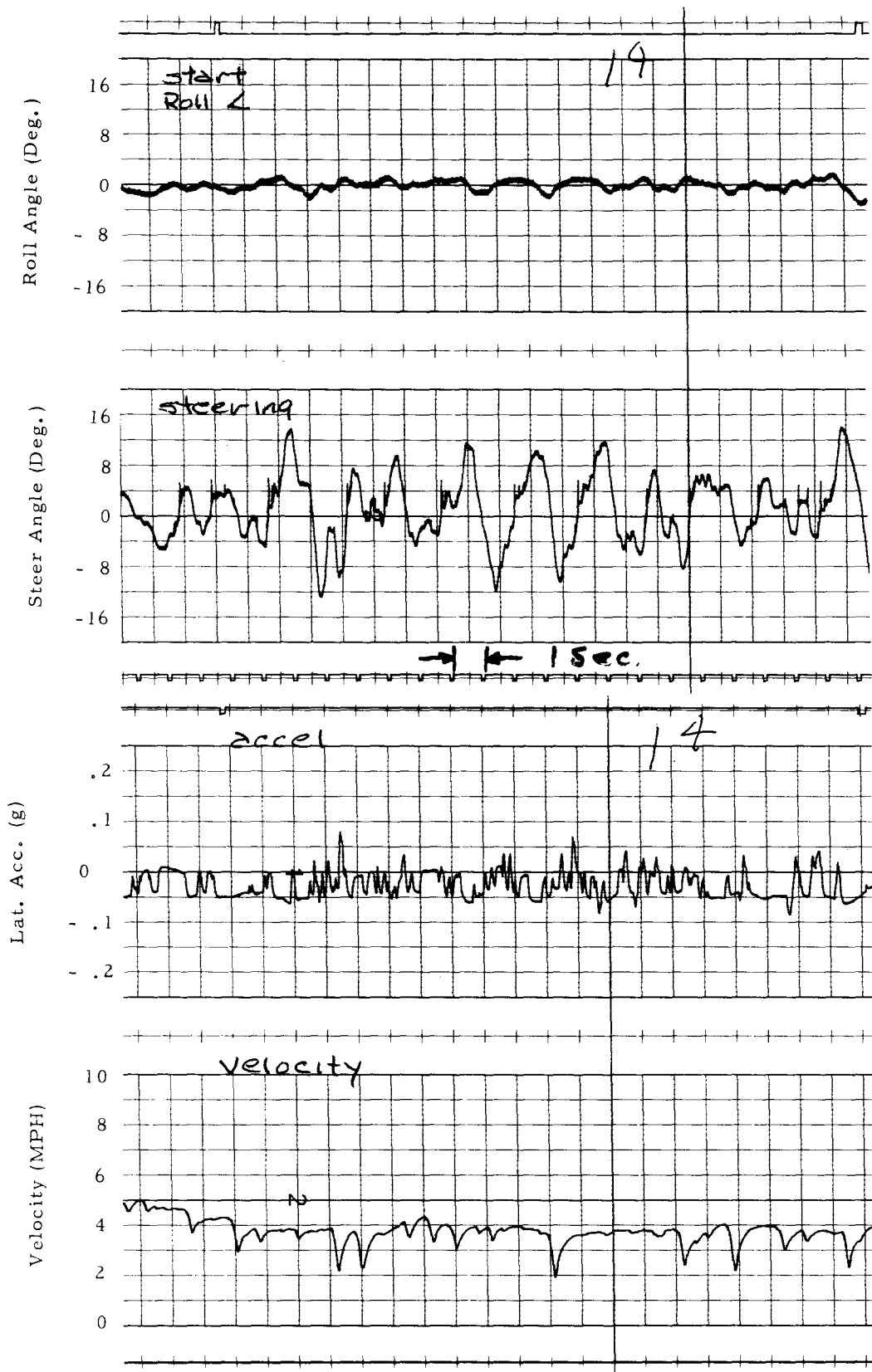

Figure II.33 Run 14, Low Speed Stability - Load on Front Carrier

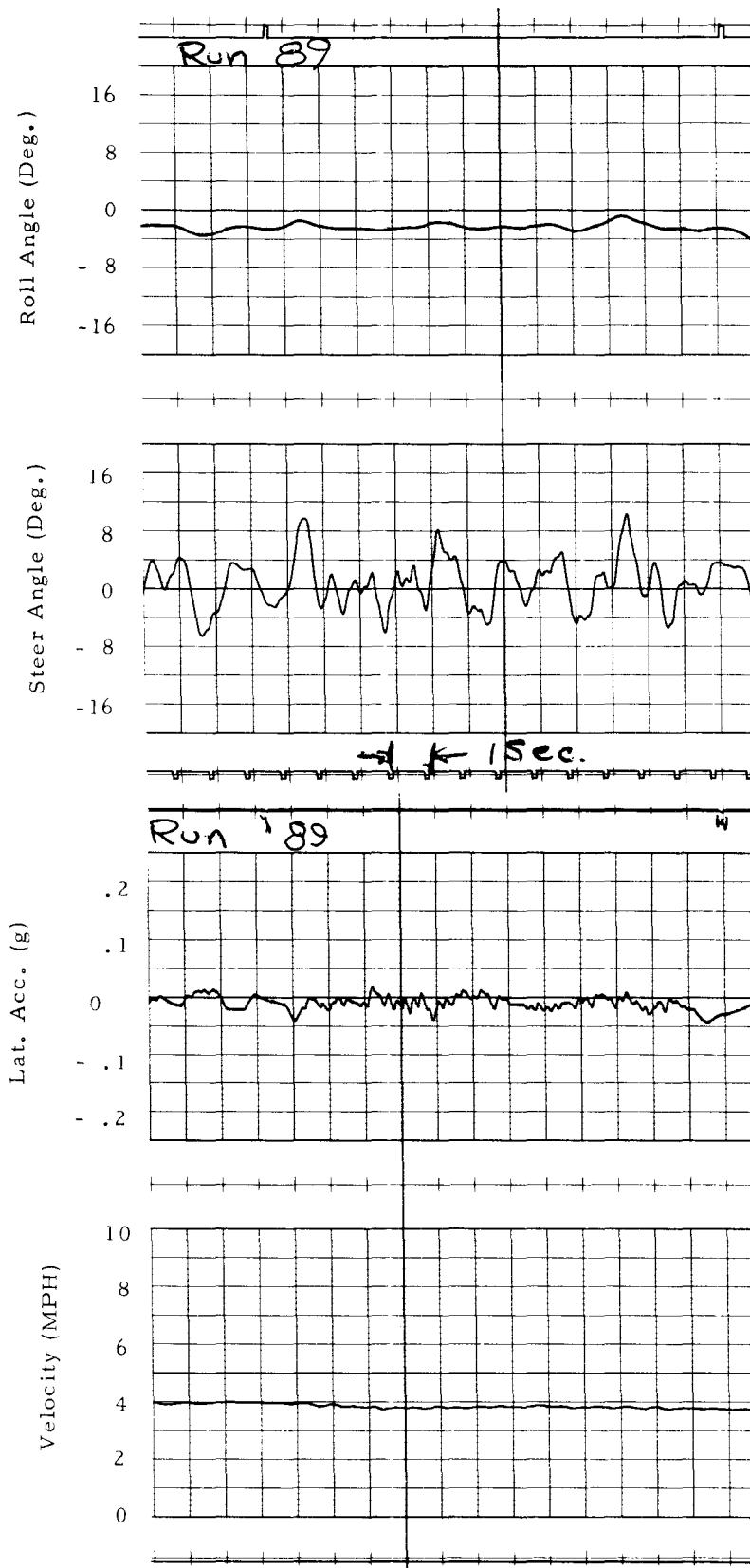

Figure II. 34 Run 89, Low Speed Stability - Load on Front and Rear Carriers

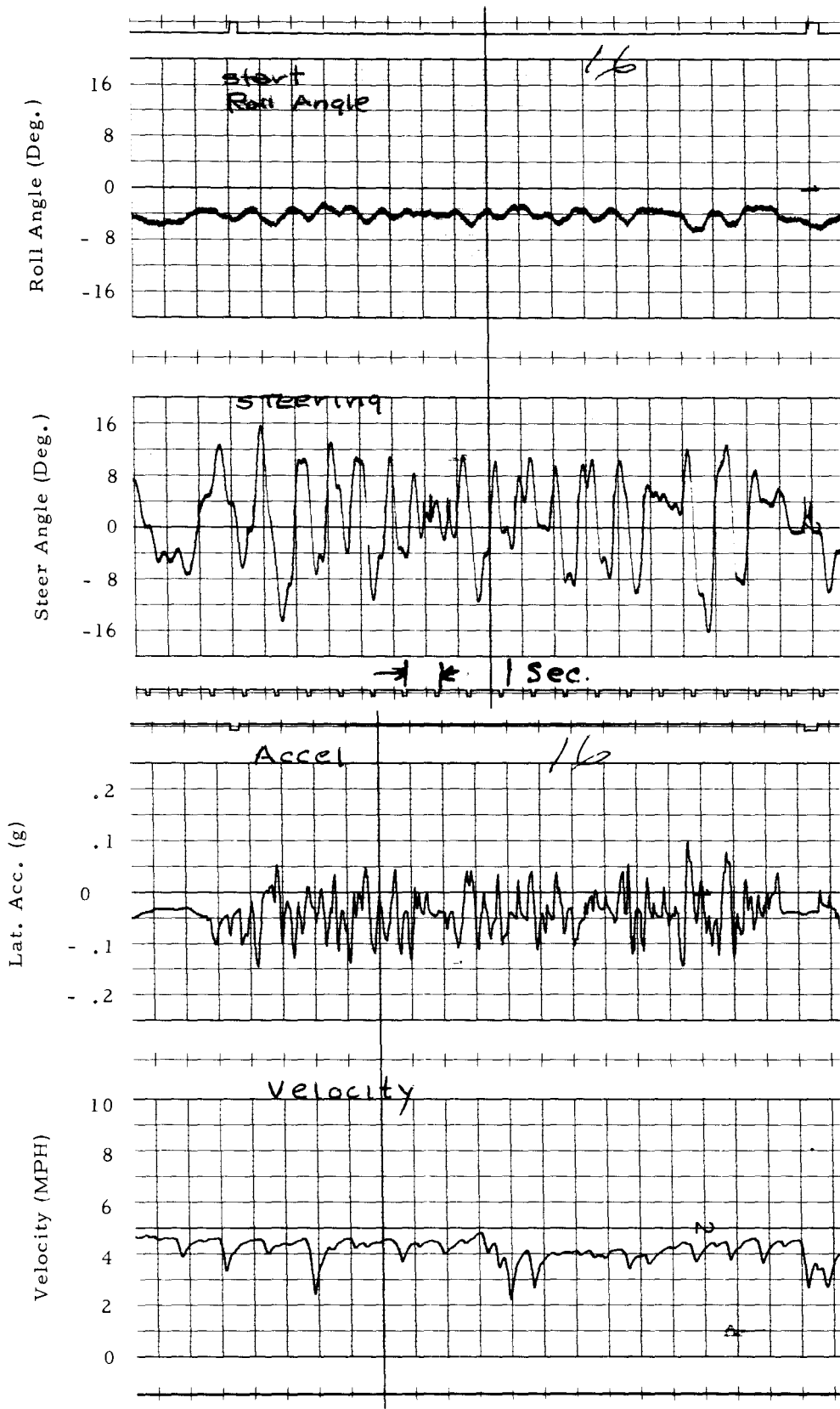

Figure II.35 Run 16, Low Speed Stability - Load in Rider's Backpack

Appendix III

1. MODIFICATION TO THEISS GRAPHICS PROGRAM

The Schwinn Bicycle Movie is built around Calvin Theiss' Single Vehicle Accident Display Program. Theiss' automobile display program is really an excellent perspective graphics system specially modified to display automotive simulations. First, Theiss' program had to be stripped of all special coding needed to draw rotating wheels, differentials, etc. The stripped down version then became a very useful perspective graphics package from which to build upon. A simplified flow chart of this generalized graphics program is shown in Figure III.1.

1.1 Displaying an Object

An object is defined as a line drawing of some entity which can be appropriately transformed and plotted into picture space. Section 6 of this appendix describes the card input for objects. Plotting an object involves a call to the object subroutine.

CALL OBJECT (TITLE, X, Y, Z, PHI, THETA, PSI)

where: *TITLE* = name of object already in storage (see Section 6)
 X, Y, Z = placement of object in inertial space
 PHI, THETA, PSI = orientation (Euler angles) of object in inertial space.

Each object is defined in its own coordinate system, and the *X, Y, Z* parameters and Euler angles correctly position the object for plotting.

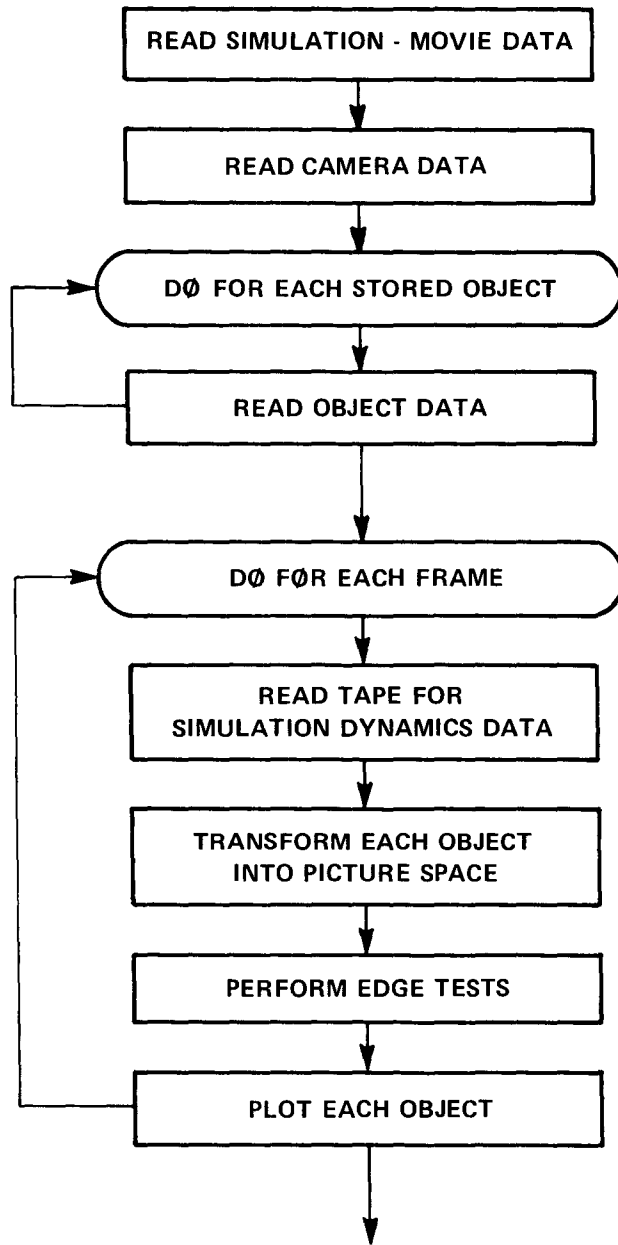

Figure III-1 FLOW CHART OF THEISS PERSPECTIVE GRAPHICS PACKAGE

1.2 Displaying the Bicycle Chassis

The Schwinn Bicycle Dynamics Simulation provides a dynamics tape of the position and orientation of the bicycle chassis, referenced to the c.g., and the steer angle, all provided at some convenient sample interval. Displaying the basic bicycle chassis would then require the following CALL:

```
CALL OBJECT (OCHAS , X,Y,Z, PHI, THETA, PSI)
```

where OCHAS = Title of stored line drawing of bicycle chassis
X, Y, Z = Fixed space positions from dynamics TAPE
Phi, Theta, Psi = Euler angles from dynamics TAPE

The graphics program will then mathematically place the chassis at the position and orientation in fixed space specified by the dynamics tape, and based on the camera data make a perspective view of the scene.

1.3 Displaying the Handlebar - Front Fork System

Mathematical complications set in from this point on. The front fork system, stored as an object, has a different X, Y, Z position and Euler angles than the basic chassis. The correct X, Y, Z positions are determined by geometry and the correct Euler angles are determined by developing the front-fork to fixed space axis system transform matrix and equating the terms in this transform matrix to like terms in the standard Euler transform matrix.

$$\begin{bmatrix} X_F \\ Y_F \\ Z_F \end{bmatrix} = [A] \cdot \left\{ [B] \cdot \begin{bmatrix} X_{STEER} \\ Y_{STEER} \\ Z_{STEER} \end{bmatrix} + \begin{bmatrix} XXF \\ YYF \\ ZZF \end{bmatrix} \right\} + \begin{bmatrix} X \\ Y \\ Z \end{bmatrix}$$

where: $(X_{\text{steer}}, Y_{\text{steer}}, Z_{\text{steer}})$ = Points in front-fork axis system
 (XXF, YYF, ZZF) = Center of front/fork system in chassis coordinates
 (X_F, Y_F, Z_F) = Front fork points transformed into fixed space
 (X, Y, Z) = Current spatial position of chassis.

$$B = \begin{bmatrix} \cos(\text{CASTER}) \cdot \cos(\text{STEER}) & -\cos(\text{CASTER}) \cdot \sin(\text{STEER}) & \sin(\text{CASTER}) \\ \sin(\text{STEER}) & \cos(\text{STEER}) & 0 \\ -\sin(\text{CASTER}) \cdot \cos(\text{STEER}) & \sin(\text{CASTER}) \cdot \sin(\text{STEER}) & \cos(\text{CASTER}) \end{bmatrix}$$

where: Caster = Front fork caster angle (from basic dimension CARDS)
Steer = Front fork steer angle (from dynamics TAPE)

$$A = \begin{bmatrix} \cos \psi \cos \theta & -\sin \psi \cos \phi + \cos \psi \sin \theta \sin \phi & \cos \psi \sin \theta \cos \phi + \sin \psi \sin \phi \\ \sin \psi \cos \theta & \cos \psi \cos \phi + \sin \psi \sin \theta \sin \phi & -\cos \psi \sin \phi + \sin \psi \sin \theta \cos \phi \\ -\sin \theta & \cos \theta \sin \phi & \cos \theta \cos \phi \end{bmatrix}$$

Standard Euler Transformation Matrix

where: ψ = yaw angle θ = pitch angle ϕ = roll angle

The Euler angles required are solved by equating coefficients in the overall transformation matrix $[AB] = [A] \cdot [B]$ to the like terms in the standard Euler transform.

For example: Equate $A(3,2)$ to $AB(3,2)$ and $AB(3,3)$ to $(3,3)$ to get the desired roll angle.

$$\cos \theta \sin \phi = AB(3,2)$$

$$\cos \theta \cos \phi = AB(3,3)$$

$$\cos \theta \frac{AB(3,2)}{\sin \phi} = \frac{AB(3,3)}{\cos \phi}$$

$$\frac{AB(3,2)}{\sin \phi} = \frac{AB(3,3)}{\cos \phi}$$

$$\frac{\sin \phi}{\cos \phi} = \frac{AB(3,2)}{AB(3,3)}$$

$$\tan \phi = \frac{AB(3,2)}{AB(3,3)}$$

$$\phi = \tan^{-1} \frac{AB(3,2)}{AB(3,3)} = \text{Roll angle of front fork system}$$

The pitch and yaw angles were solved in a similar fashion:

$$\psi = \tan^{-1} \left(\frac{AB(2,1)}{AB(1,1)} \right) = \text{yaw angle of front fork}$$

$$\theta = \tan^{-1} \left(\frac{-AB(3,1) * \sin \psi}{AB(2,1)} \right) = \text{pitch angle of front fork system}$$

A special subroutine was written which does the above job automatically. It takes the matrix coefficients of the Euler transform and the object-to-chassis axis transform and returns the proper Euler angles. To correctly plot the front fork, one has to convert the center of the front fork system into fixed coordinates and CALL the subroutine OBJECT.

$$\begin{bmatrix} XFFA \\ YFFA \\ ZFFA \end{bmatrix} = [A] \cdot \begin{bmatrix} XXF \\ YYF \\ ZZF \end{bmatrix} + \begin{bmatrix} X \\ Y \\ Z \end{bmatrix}$$

where X, Y, Z = current fixed axis position of the bicycle (from dynamics TAPE)

Plotting the front-fork is accomplished by:

```
CALL OBJECT (OFFORK, XFFA, YFFA, ZFFA, PHIF,)
```

The rest of the Schwinn Bicycle Graphics computation follows the same pattern - determination of the object to chassis axis transform, solving for the Euler angles, solving for the correct fixed space (X, Y, Z) positions, and calling subroutine OBJECT. There will be no need to go into this much detail on the following items.

1.4 Displaying the Pedals

The pedals rotate through an angle ω and only require a simple pedal-to-chassis transform:

$$\begin{bmatrix} X_F \\ Y_F \\ Z_F \end{bmatrix} = [A] \left\{ [C] \begin{bmatrix} X_{PEDAL} \\ Y_{PEDAL} \\ Z_{PEDAL} \end{bmatrix} + \begin{bmatrix} XXP \\ YYP \\ ZZP \end{bmatrix} \right\} + \begin{bmatrix} X \\ Y \\ Z \end{bmatrix}$$

where $C = \begin{bmatrix} \cos \omega & 0 & -\sin \omega \\ 0 & 1 & 0 \\ \sin \omega & 0 & \cos \omega \end{bmatrix}$

(XXP, YYP, ZZP) = center of pedal system in chassis coordinates

(X_{pedal} , Y_{pedal} , Z_{pedal}) = points in pedal object description

= angle of pedals

(X, Y, Z) = current spatial position of bicycle

ω is determined by calculating the distance traveled since the last frame and relating this distance to the wheelsize and gear ratio

$$DIST = \sqrt{(X_{OLD} - X_{NEW})^2 + (Y_{OLD} - Y_{NEW})^2 + (Z_{OLD} - Z_{NEW})^2}$$

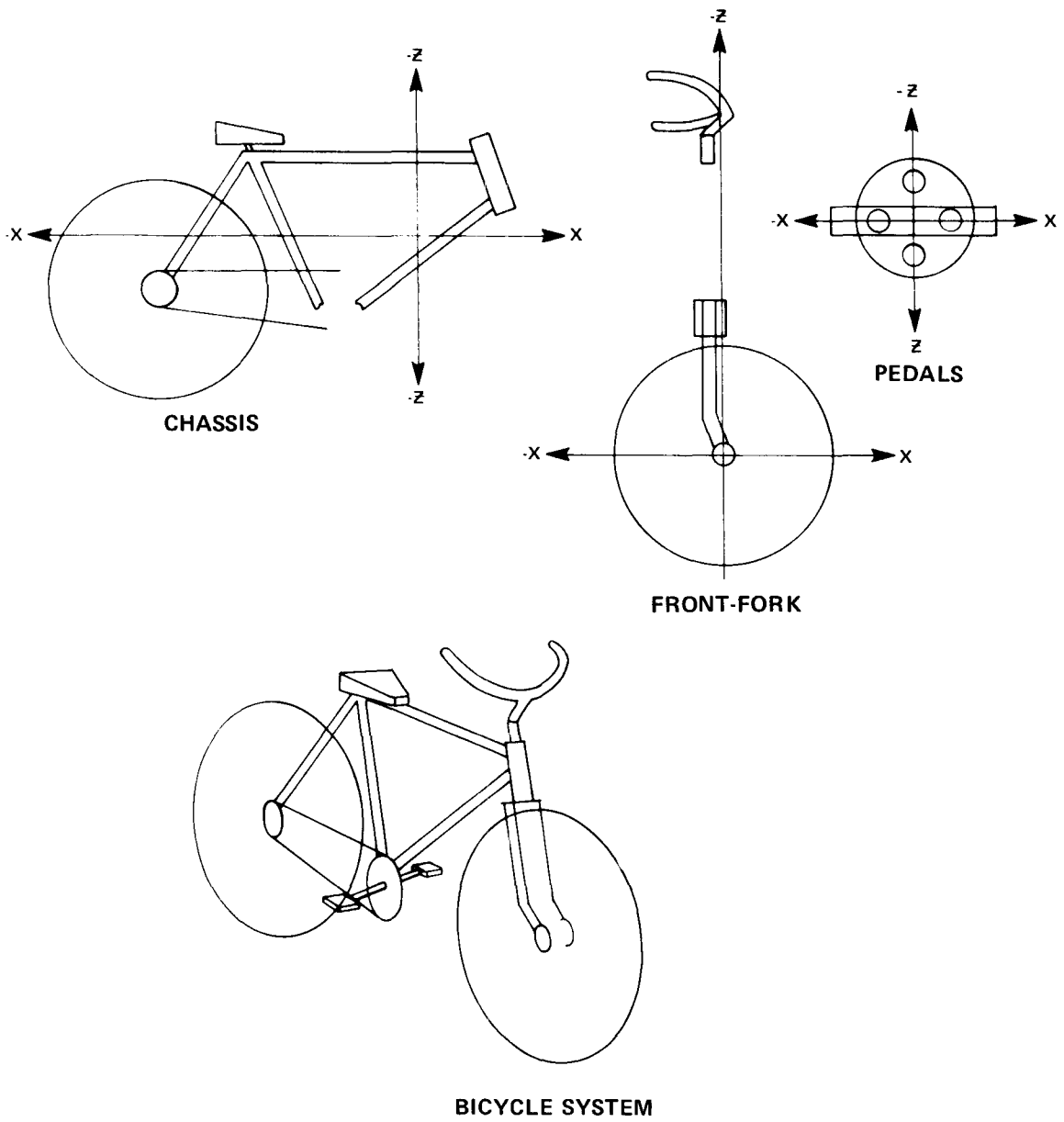

Figure III-2

$$\omega = -.3 * DIST/wheelsize + \omega_{OLD}$$

where = .3 = gear ratio ω_{OLD} = past value of ω

Figure III.2 shows the relationship between the 3 sections of the bicycle chassis, namely the chassis, the front-fork, and the pedals.

2.0 Attaching the Rider

The positioning and plotting of the rider poses some interesting problems. The method used will be similar to the way the front-fork and the pedals were plotted, namely introducing each part as an individual object and correctly specifying the spatial positions and Euler angles to do the job.

Figure III.3 shows the rider and associated joints. Note that each leg has three dynamic joints (thigh action, calf action, and toe action) and that each arm has two dynamic joints (upper arm action and forearm action). The whole torso can lean to the left or right. Two major simplifying assumptions are applied in the solution - that leg action is in one plane only and that the armpit angle is constant.

2.1 The Pedaling Action

It was decided that simulation of the rider ankle action would add much to the realism of the graphic display. A simple toe angle approximation was employed.

$$\text{Toe angle (left)} = -.25 * \cos(\omega) \quad \text{Toe angle (right)} = .25 * \cos(\omega)$$

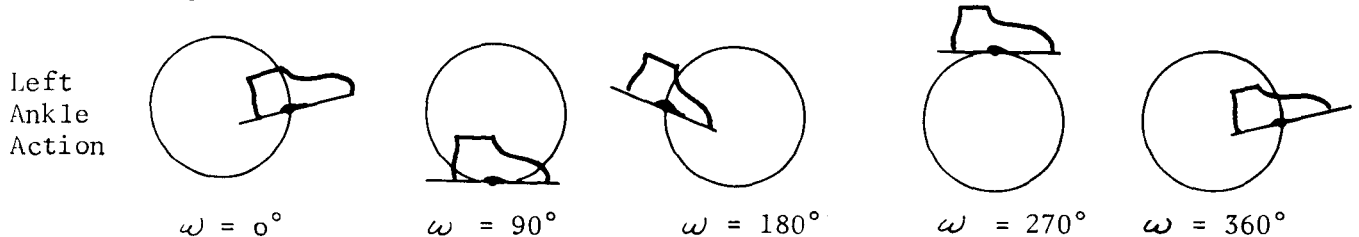

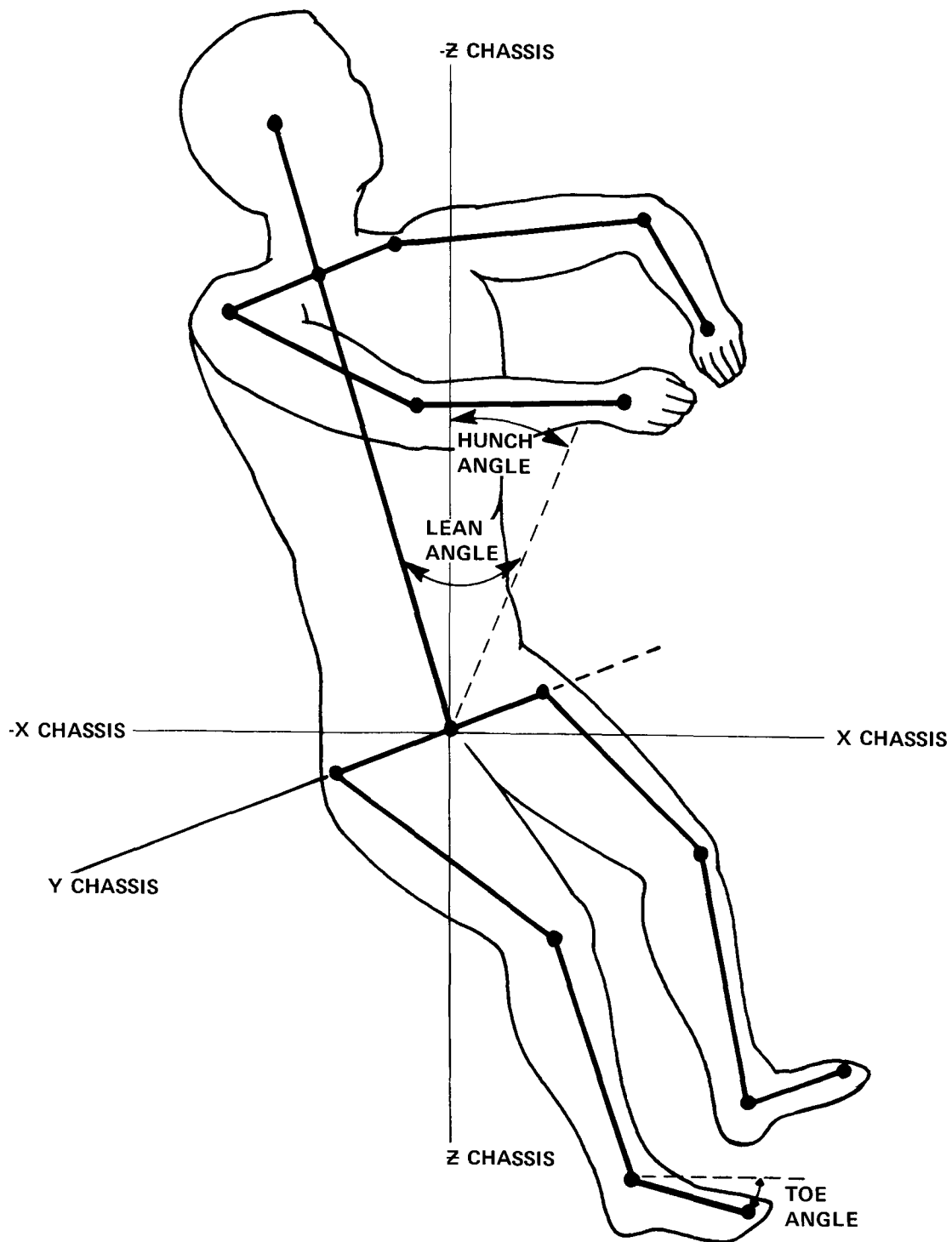
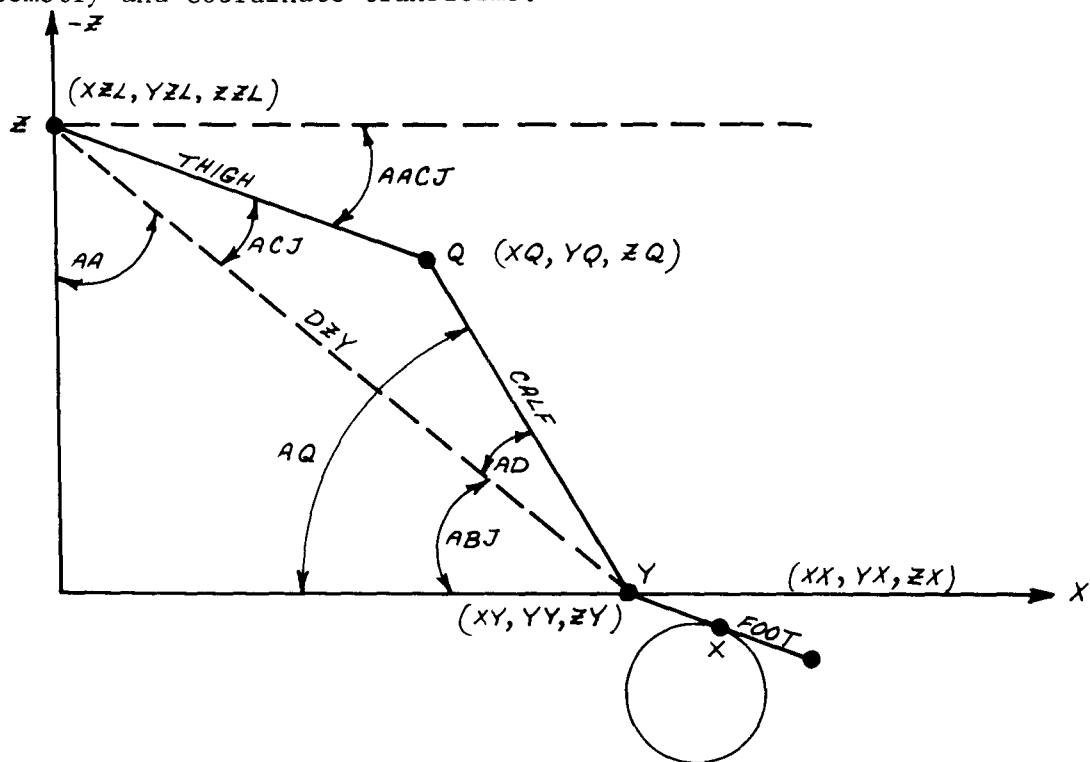

Figure III-3

The positions of the thigh, calf, and foot must be calculated by geometry and coordinate transforms.



The geometrical calculations necessary are the following.

Calculation of Point X

$$\begin{bmatrix} XX \\ YX \\ ZX \end{bmatrix} = \begin{bmatrix} \cos(\omega) & 0 & \sin(\omega) \\ 0 & 1 & 0 \\ -\sin(\omega) & 0 & \cos(\omega) \end{bmatrix} \begin{bmatrix} XPL \\ YPL \\ ZPL \end{bmatrix} + \begin{bmatrix} XXP \\ YYP \\ ZZP \end{bmatrix}$$

where: (XPL, YPL, ZPL) = coordinates of foot-pedal connection in pedal axis
 (XXP, YYP, ZZP) = center of pedal system in chassis coordinates

Calculation of Point Y

$$XY = XX - \cos(\text{TOE ANGLE}) * HF$$

$$YY = YX$$

$$ZY = ZX - \sin(\text{TOE ANGLE}) * HF$$

where: (XX, YX, ZX) = chassis coordinates of point X

HF = half a foot (distance YX)

Other Calculations (Refer to diagram)

$$DZY = \sqrt{(XZL - XY)^2 + (YZL - YY)^2 + (ZZL - ZY)^2}$$

$$AA = \tan^{-1} \left((XY - XZL) / (ZY - ZZL) \right)$$

$$P = \frac{1}{2} (DZY + THIGH + CALF)$$

$$R = \sqrt{\left[(P - DZY)(P - CALF)(P - THIGH) \right] / P}$$

$$ACJ = 2 * \tan^{-1} \left(R / (P - CALF) \right)$$

$$AD = 2 * \tan^{-1} \left(R / (P - THIGH) \right)$$

$$ABJ = 1.5707 - AA$$

$$AACJ = 1.5707 - AA - ACJ$$

$$AQ = ABJ + AD$$

$$XQ = THIGH * \sin(AA + ACJ) + XZL$$

$$YQ = YZL$$

$$ZQ = THIGH * \cos(AA + ACJ) + ZZL$$

2.2 Displaying the THIGH

The thigh is connected at point Z and rotated downward by angle AACJ. The Euler angles are determined from the following relationship.

$$\begin{bmatrix} X_F \\ Y_F \\ Z_F \end{bmatrix} = [A] \left\{ \begin{bmatrix} \cos(AACJ) & 0 & -\sin(AACJ) \\ 0 & 1 & 0 \\ \sin(AACJ) & 0 & \cos(AACJ) \end{bmatrix} \begin{bmatrix} X_{THIGH} \\ Y_{THIGH} \\ Z_{THIGH} \end{bmatrix} + \begin{bmatrix} XZL \\ YZL \\ ZZL \end{bmatrix} \right\} + \begin{bmatrix} X \\ Y \\ Z \end{bmatrix}$$

where: AACJ = angle from horizontal thigh is rotated downward.
 (XZL, YZL, ZZL) = hip to thigh tie point in chassis coordinates
 (X_{thigh}, Y_{thigh}, Z_{thigh}) = points in thigh axis system
 (X, Y, Z) = current spatial position of bicycle

Finally, the fixed space position of the center of the thigh axis system is solved from the following relationship.

$$\begin{bmatrix} X_{LT} \\ Y_{LT} \\ Z_{LT} \end{bmatrix} = A \begin{bmatrix} XZL \\ YZL \\ ZZL \end{bmatrix} + \begin{bmatrix} X \\ Y \\ Z \end{bmatrix}$$

2.3 Displaying the CALF

The calf is displayed exactly the same way as the thigh. The Euler angles are determined from the following relationship:

$$\begin{bmatrix} X_F \\ Y_F \\ Z_F \end{bmatrix} = [A] \left\{ \begin{bmatrix} \cos(AQ) & 0 & -\sin(AQ) \\ 0 & 1 & 0 \\ \sin & 0 & \cos(AQ) \end{bmatrix} \begin{bmatrix} X_{CALF} \\ Y_{CALF} \\ Z_{CALF} \end{bmatrix} + \begin{bmatrix} X_Q \\ Y_Q \\ Z_Q \end{bmatrix} \right\} + \begin{bmatrix} X \\ Y \\ Z \end{bmatrix}$$

where: AQ = angle from horizontal calf is rotated downward.
 (XZL, YZL, ZZL) = hip to thigh tie point in chassis coordinates

(XQ, YQ, ZQ) = point Q in chassis axis coordinates

(X, Y, Z) = current spatial position of bicycle.

The fixed space position of the center of the calf axis system is solved from the following relationship.

$$\begin{bmatrix} XC \\ YC \\ ZC \end{bmatrix} = [A] \begin{bmatrix} XQ \\ YQ \\ ZQ \end{bmatrix} + \begin{bmatrix} X \\ Y \\ Z \end{bmatrix}$$

2.4 Displaying the FOOT

Likewise, the foot is displayed with techniques like those used for the thigh and calf. The Euler angles are determined from the following relationship.

$$\begin{bmatrix} X_F \\ Y_F \\ Z_F \end{bmatrix} = [A] \left\{ \begin{bmatrix} \cos(\text{TOE ANGLE}) & 0 & -\sin(\text{TOE ANGLE}) \\ 0 & 1 & 0 \\ \sin(\text{TOE ANGLE}) & 0 & \cos(\text{TOE ANGLE}) \end{bmatrix} \begin{bmatrix} X_{\text{FOOT}} \\ Y_{\text{FOOT}} \\ Z_{\text{FOOT}} \end{bmatrix} + \begin{bmatrix} XX \\ YX \\ ZX \end{bmatrix} \right\} + \begin{bmatrix} X \\ Y \\ Z \end{bmatrix}$$

where: Toe angle = angle at which foot is rotated from horizontal

(X_{foot}, Y_{foot}, Z_{foot}) = points in foot axis system

(XX, YX, ZX) = point X in chassis axis coordinates

(X, Y, Z) = current spatial position of bicycle

The fixed space position of the center of the foot axis system is solved from the following relationship.

$$\begin{bmatrix} XXX \\ YYX \\ ZZX \end{bmatrix} = [A] \begin{bmatrix} XX \\ YX \\ ZX \end{bmatrix} + \begin{bmatrix} X \\ Y \\ Z \end{bmatrix}$$

All of the past sections of this appendix concerning display of the legs have shown examples of left-leg computations, suffice it to say that right leg computations are similar, excepting for the differing tie points and toe angles.

2.5 Displaying the TORSO

The torso undergoes two rotations, hunching over and leaning from side to side. The hunch angle comes from the basic dimension CARD and the lean angle comes from the dynamics TAPE. The Euler angles are determined from the following relationship:

$$\begin{bmatrix} X_F \\ Y_F \\ Z_F \end{bmatrix} = [A] \left\{ \begin{bmatrix} \cos(AH) & \sin(AH) \cdot \sin(AL) & -\sin(AH) \cdot \cos(AL) \\ 0 & \cos(AL) & 0 \\ \sin(AH) & -\cos(AH) \cdot \sin(AL) & \cos(AH) \cdot \cos(AL) \end{bmatrix} \cdot \begin{bmatrix} X_{TORSO} \\ Y_{TORSO} \\ Z_{TORSO} \end{bmatrix} + \begin{bmatrix} X_S \\ Y_S \\ Z_S \end{bmatrix} \right\} + \begin{bmatrix} X \\ Y \\ Z \end{bmatrix}$$

where: AH = hunch angle

AL = lean angle

(X_{torso} , Y_{torso} , Z_{torso}) = points in the torso axis system

(X_S , Y_S , Z_S) = coordinates of center of torso axis system in chassis system

(X , Y , Z) = current spatial position of bicycle

The fixed space position of the center of the torso axis system is determined by the following relationship:

$$\begin{bmatrix} XXS \\ YYS \\ ZZS \end{bmatrix} = [A] \begin{bmatrix} X_S \\ Y_S \\ Z_S \end{bmatrix} + \begin{bmatrix} X \\ Y \\ Z \end{bmatrix}$$

where: (XXS, YYS, ZZS) = coordinates of center of torso axis in fixed space.

2.6 Displaying the ARMS

The solution for the arms is not immediately obvious, for as is seen in Figure III.4, the elbow can trace out a circle of points. A few simplifying assumptions can be of assistance. If the upper arm and the forearm are equal in length, then the perpendicular distance from the elbow to the handlebar-shoulder line can be determined. A transformation matrix can be developed to convert points in the elbow circle plane to the chassis axis system. In the elbow circle system, a constant shoulder **angle** can be chosen to specify an elbow point - this can be transformed back into the chassis set. Once the elbow point is known, the job is quite **straightforward**.

2.7 Calculation of the Elbow Points

Direction Numbers of Line DSH:

$$U = (XHL-XSL) \quad V = (YHL-YSL) \quad W = (ZHL-ZSL)$$

where: (XHL, YHL, ZHL) are left handlebar tie points in chassis coordinates.
(XSL, YSL, ZSL) are left shoulder tie points in chassis coordinates.

Transformation matrices have already been developed to convert the tie points from their own axis set into chassis coordinates.

Distance from Shoulder to Handlebar

$$DSH = \sqrt{U^2 + V^2 + W^2}$$

Direction Cosines

$$\lambda = U/DSH \quad \mu = V/DSH \quad \nu = W/DSH$$

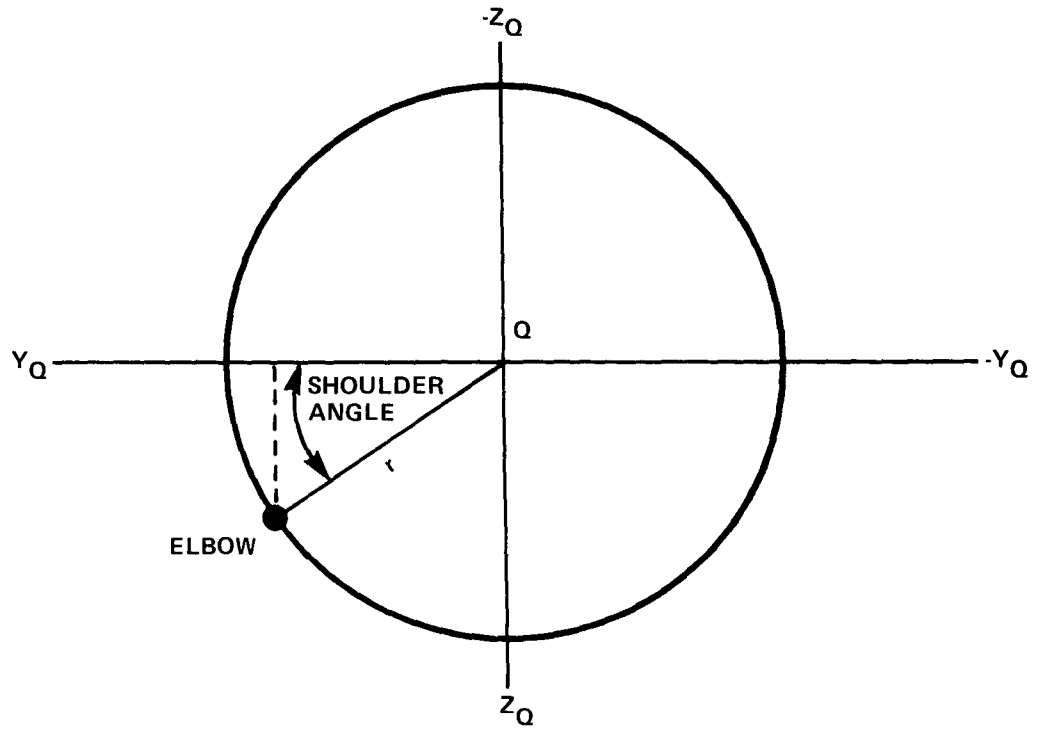
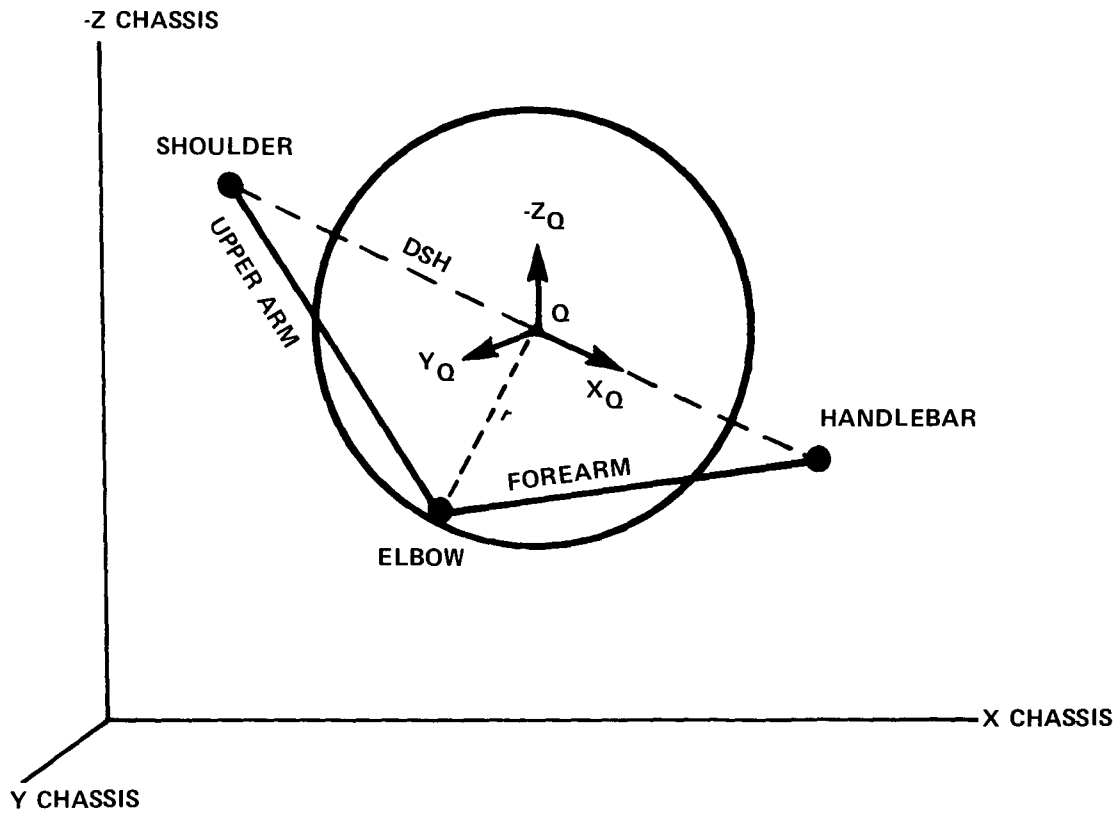

Figure III-4

Euler Angles to Transform Chassis Axis into Elbow Plane

$$\text{Yaw: } \psi = \text{TAN}^{-1} (u/\lambda)$$

$$\text{Pitch: } \theta = -\text{TAN}^{-1} (v/\sqrt{\lambda^2 + u^2})$$

Distance from Point Q to Elbow

$$\text{DQE} = \sqrt{\text{upperarm}^2 + (\text{DSH}/2)^2}$$

Calculation of Elbow Point in Elbow Axis System

$$\text{XEP} = 0$$

$$\text{YEP} = -\text{DQE} * \text{COS} (\text{armpit angle})$$

$$\text{ZEP} = \text{DQE} * \text{SIN} (\text{armpit angle})$$

Transformation of Elbow Point into Chassis Axis System

$$\begin{bmatrix} X_{EL} \\ Y_{EL} \\ Z_{EL} \end{bmatrix} = \begin{bmatrix} \text{COS } \psi \text{ COS } \theta & -\text{SIN } \psi & \text{COS } \psi \text{ SIN } \theta \\ \text{SIN } \psi \text{ COS } \theta & \text{COS } \psi & \text{SIN } \psi \text{ SIN } \theta \\ -\text{SIN } \theta & 0 & \text{COS } \theta \end{bmatrix} \cdot \begin{bmatrix} X_{EP} \\ Y_{EP} \\ Z_{EP} \end{bmatrix} + \begin{bmatrix} X_{QL} \\ Y_{QL} \\ Z_{QL} \end{bmatrix}$$

where: (ψ, θ) = Euler angles previously determined
 (X_{ep}, Y_{ep}, Z_{ep}) = Elbow point in elbow axis coordinates
 $X_{QL} = .5 * (X_{SL} + X_{HL})$
 $Y_{QL} = .5 * (Y_{SL} + Y_{HL})$
 $Z_{QL} = .5 * (Z_{SL} + Z_{HL})$

2.8 Display the Upper Arms

Two Euler rotations are needed to position the upper arms, and these two Euler angles are calculated in the following way:

$$\begin{aligned} \lambda &= (XEL-XSL)/\text{upperarm} \\ u &= (YEL-YSL)/\text{upperarm} \\ v &= (ZEL-ZSL)/\text{upperarm} \\ \psi &= \text{TAN}^{-1}(u/v) \\ \theta &= \text{TAN}^{-1}(v/\sqrt{\lambda^2 + u^2}) \end{aligned}$$

The Euler angles required to rotate the upperarms into the fixed space set are calculated, as usual, from the following relationship.

$$\begin{bmatrix} X_F \\ Y_F \\ Z_F \end{bmatrix} [A] \begin{bmatrix} \cos(\psi) \cdot \cos(\theta) & -\sin(\psi) \cos(\psi) \cdot \sin(\theta) \\ \sin(\psi) \cdot \cos(\theta) & \cos(\psi) \sin(\psi) \cdot \sin(\theta) \\ -\sin(\theta) & 0 & \cos(\theta) \end{bmatrix} \left\{ \begin{bmatrix} X_{UA} \\ Y_{UA} \\ Z_{UA} \end{bmatrix} + \begin{bmatrix} X_{SL} \\ Y_{SL} \\ Z_{SL} \end{bmatrix} \right\} + \begin{bmatrix} X \\ Y \\ Z \end{bmatrix}$$

where: (XUA, YUA, ZUA) = points in upper arm axis system
 (XSL, YSL, ZSL) = shoulder tie points converted to chassis axis system.
 (X, Y, Z) = current spatial position of bicycle.

The fixed space position of the center of the upperarm axis system is determined by the following relationships.

$$\begin{bmatrix} X_{SLF} \\ Y_{SLF} \\ Z_{SLF} \end{bmatrix} = [A] \begin{bmatrix} X_{SL} \\ Y_{SL} \\ Z_{SL} \end{bmatrix} + \begin{bmatrix} X \\ Y \\ Z \end{bmatrix}$$

2.9 Displaying the Forearms

Two Euler rotations are needed to position the upper arms, and these two Euler angles are calculated in the following way:

$$\begin{aligned}\lambda &= (XHL - XEL) / \text{forearm} \\ u &= (YHL - YEL) / \text{forearm} \\ v &= (ZHL - ZEL) / \text{forearm} \\ \psi &= \text{TAN}^{-1} \left(\frac{u}{v} \right) \\ \theta &= \text{TAN}^{-1} \left(\frac{v}{\sqrt{\lambda^2 + u^2}} \right)\end{aligned}$$

The Euler angles required to rotate the forearms into the fixed space set are calculated from the following relationship:

$$\begin{bmatrix} X_F \\ Y_F \\ Z_F \end{bmatrix} [A] \left\{ \begin{bmatrix} \cos(\psi) \cdot \cos(\theta) & -\sin(\psi) & \cos(\psi) \cdot \sin(\theta) \\ \sin(\psi) \cdot \cos(\theta) & \cos(\psi) & \sin(\psi) \cdot \sin(\theta) \\ -\sin(\theta) & 0 & \cos(\theta) \end{bmatrix} \begin{bmatrix} X_{FA} \\ Y_{FA} \\ Z_{FA} \end{bmatrix} + \begin{bmatrix} X_{EL} \\ Y_{EL} \\ Z_{EL} \end{bmatrix} \right\} + \begin{bmatrix} X \\ Y \\ Z \end{bmatrix}$$

where: (XFA, YFA, ZFA) = Points in forearm axis system
 (XEL, YEL, ZEL) = Elbow point in chassis axis system
 (X, Y, Z) = Current spatial position of bicycle.

The fixed space position of the center of the forearm axis system is determined by the following relationship:

$$\begin{bmatrix} X_{ELF} \\ Y_{ELF} \\ Z_{ELF} \end{bmatrix} = [A] \begin{bmatrix} X_{EL} \\ Y_{EL} \\ Z_{EL} \end{bmatrix} + \begin{bmatrix} X \\ Y \\ Z \end{bmatrix}$$

The examples used in the previous sections concerning the arms concerned the left arm; however the right arm is displayed is the same way.

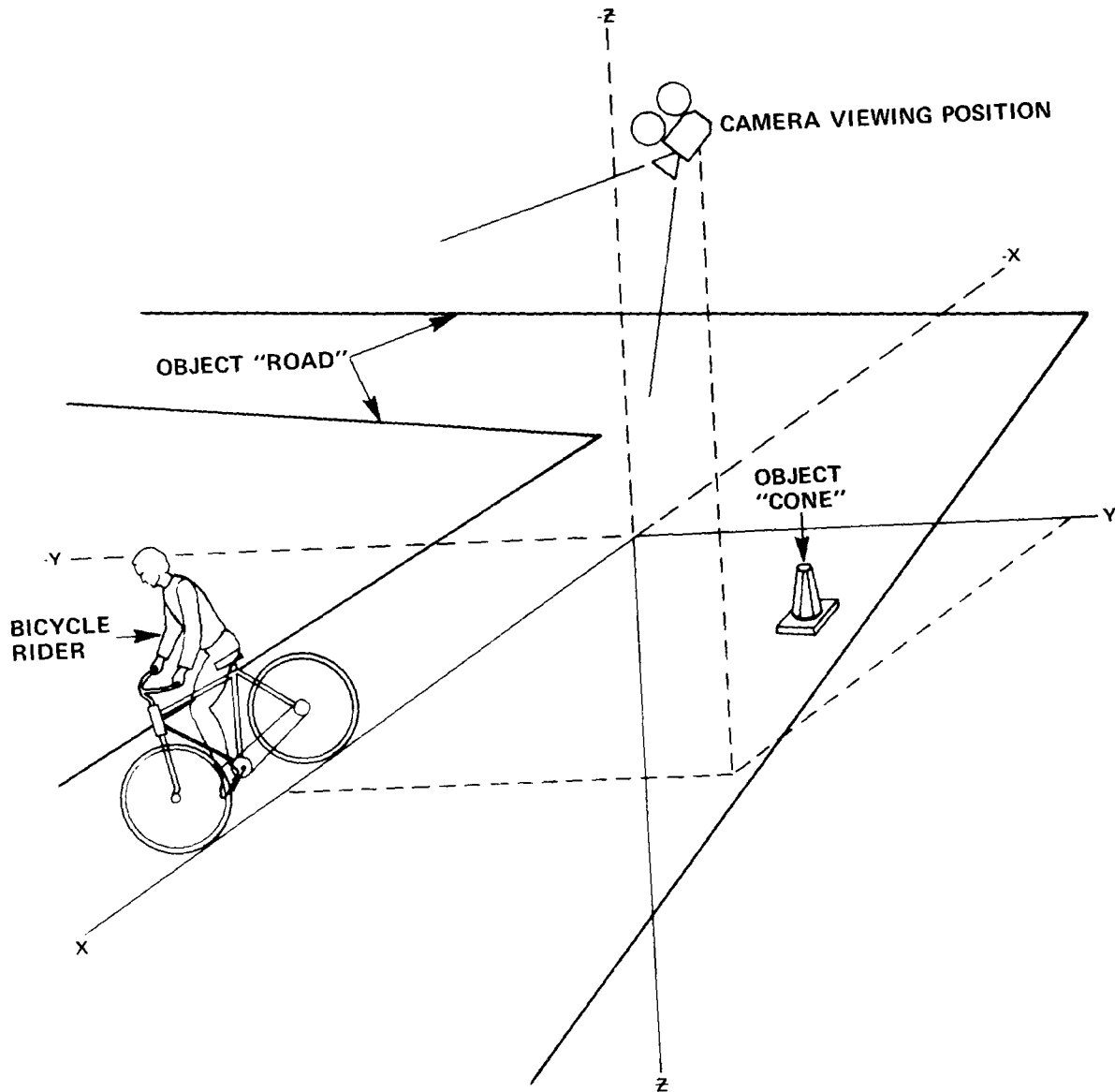

Figure III-5

3. GENERAL USAGE INFORMATION

To get a picture using this program, you will have to supply the following:

- (1) A suitable dynamics tape (and associated DD card, naturally)
- (2) A copy of the Schwinn Bicycle Graphics Program.
- (3) FORTRAN data cards to control the simulation-graphics process

3.1 Coordinate Systems

The user need only know how to plot objects on the simulation plane and how to point the movie camera. Figures III.5 and III.6 show the layout of the coordinate system. The important considerations are:

- (1) All data points for this program are in inches.
- (2) Minus Z-axis is up.
- (3) Camera azimuth angle works like this (clockwise from +X):

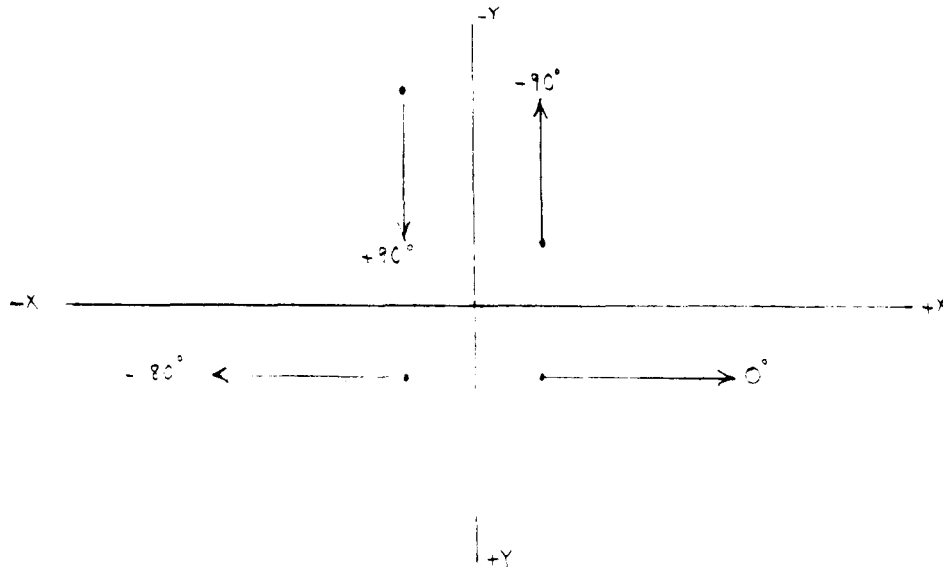

Figure III.6

TOP VIEW - CAMERA AZIMUTH ANGLES

3.2 Making Plots

The Schwinn Bicycle Graphics Program is all set up to make CALCOMP, HOUSTON, or LDX plots with only the standard JCL catalogued procedures.

3.3 Making Movies

Generation of SPAYZ movies involves several special DD cards and careful attention to scheduling. Users are advised to interface with Harvey Selib and Ham Maynard, Department 45 for proper JCL and SPAYZ setup.

3.4 Data Card Types (in sequence of appearance)

The following 10 card types must be present to get a picture or make a movie. There are two other card types that are optional. They are: (1) PRE-RUN CARDS, which allow you to "splice" in a previously run sequence of pictures, and (2) CHANGE CARDS, which allow you to change things like camera position parameters in the middle of a run. Details of the formats of these, as well as of the 10 basic card types are given in Section 4.

1. IDENTIFICATION CARD - gives a name to this particular run. Slight variation of this card terminates run.
2. INSTRUCTION CARD - provides a lot of simulation type information, such as no. of frames per second, starting and ending times, etc.
3. FIRST CAMERA CARD - provides program with details on position of camera, if auto. pan and zoom is wanted, etc.
4. SECOND CAMERA CARD - If it is desired that the camera position parameters are to change by some increment each new frame, this card describes these increments.
5. BASIC DIMENSION CARD - This card sends basic chassis dimensions to the program.
6. OBJECT DELETE CARDS - Note that an object is any entity that is included in the picture (chassis, roadway, tree). If an object is already in storage, it can be removed by this card.

Note: A blank card is used to specify if there are no more object delete cards.

7. OBJECT CARDS

- A. OBJECT TITLE CARDS - Specify that the next group of cards represent some plottable object like a chassis or tree.

- B. OBJECT SPECIFICATION CARDS - Sequential list of points that are to be connected together to draw an object.

Note: Each group of connected points in an object will have a modified object title card. A blank card indicates no more objects to be read in.

8. SKIP CARDS - Occasionally you will want to process the first three runs on a dynamics tape and then jump to the last three runs on the tape; the skip cards allow you to skip around the tape this way.
9. PATTERN CARDS - The pattern cards specify which of the aforementioned objects are not to be moved, rotated, or translated by the dynamics tape (example: roadways, curbs, etc.).

Note: A blank card means no more pattern cards.

10. STOP CARD - A modified form of the IDENTIFICATION CARD, this card ends the input deck.

3.5 Things to Ignore

1. This program constantly gives out SIN-COS argument diagnostics. They have no effect on the results and can be ignored.
2. If the chassis moves out of the picture frame, divide check diagnostics are created. These can be ignored also.
3. There is a subroutine called PLTSET in the program that is a dummy. Ignore its presence.

4. INPUT DATA CARD DETAILS

The following is a more complete description of the data cards for the Schwinn Bicycle Graphics Program. An example of each card is included. The FORTRAN names of the data as used in the program is shown in capital letters (for those who wish to dig around in the source code).

1. IDENTIFICATION CARD

72 columns of optional script, 8 columns of integers, DENT, ITEST
First 4 columns are important: **** Read rest of card
STOP terminates the program
Note: If columns 5-8 have ****
(STOP col 1-4), then the next card must have the number
of frames in which THE END is
printed (4 integers).

Example: First card in the data deck:

```

1 2 3 4 5 6 7 8 9 10 11 12 13 14 15 16 17 18 19 20 21 22 23 24 25 26 27 28 29 30 31 32 33 34 35 36 37 38 39 40 41 42 43 44 45 46 47 48 49 50 51 52 53 54 55 56 57 58 59 60 61 62 63 64 65 66 67 68 69 70 71 72 73 74 75 76 77 78 79 80

```

Example: Last card in the data deck:

STOP****

```

1 2 3 4 5 6 7 8 9 10 11 12 13 14 15 16 17 18 19 20 21 22 23 24 25 26 27 28 29 30 31 32 33 34 35 36 37 38 39 40 41 42 43 44 45 46 47 48 49 50 51 52 53 54 55 56 57 58 59 60 61 62 63 64 65 66 67 68 69 70 71 72 73 74 75 76 77 78 79 80

```

2. INSTRUCTION CARD

Col. 1-6	Width of picture frame	WIDE	
Col. 7-12	Height of picture frame	HIGH	
Col. 13-18	Time when movie sequence begins	TB	
Col. 19-24	Time when movie sequence ends	TE	
Col. 25-30	Time between movie frames	DT	
Col. 31-36	Size of lettering on frames	STDISP	
Col. 37-42	Time tolerance on matching frames	EPST	
	-1	previously run sequence with previously used velocity and acceleration vectors.	
Col. 43-44	+1	previously run sequence with a prerun card setting velocity and acceleration vectors.	IPRUN
	0	new sequence of vectors.	
Col. 45-46		Not used.	
Col. 47		Not used.	
Col. 48		Not used.	
Col. 49	{ 1	print time of each frame	LF
	{ 0	do not print frame time	
Col. 50	{ 1	new camera data will be read in	ICAM
	{ 0	no new camera data	
Col. 51	{ 1	put all sequences on one frame (double exposure effect)	IREP
	{ 0	one picture/frame	

Col. 52	{ 1 0	draw a border no border	IFRAME
Col. 53-54		No. of trajectory tape (minus sign rewinds it).	IT
Col. 55-56	{ -1 0 1	use old chassis use no chassis read in new chassis	ICHAS
Col. 57-58	{ 0 1	do nothing read in new basic dimensions	INIT
Col. 59-60	{ 0 NN	no change card expected No. of test in which change card will be used	ICHANG
Col. 61-64	{ 0 0	no. of skip numbers that will be expected default values will be used	NSKIP
Col. 65-68	{ 1 0	ignore previously specified backgrounds use previously specified backgrounds	IOBC
Col. 69-72	{ 0 70	no title shots produced no. of frames that title is generated	ITIT
Col. 73-74		no. of characters in the title	NTIT
Col. 75-80		height of title characters	STIT

Example: INSTRUCTION CARD

14.0 14.0 0.0 1.8 .05 .14 .001 00000 11 101010100 2 100290.20

1 2 3 4 5 6 7 8 9 10 11 12 13 14 15 16 17 18 19 20 21 22 23 24 25 26 27 28 29 30 31 32 33 34 35 36 37 38 39 40 41 42 43 44 45 46 47 48 49 50 51 52 53 54 55 56 57 58 59 60 61 62 63 64 65 66 67 68 69 70 71 72 73 74 75 76 77 78 79 80

3. CAMERA CARDS (used only if ICAM ≠ 0)

(first camera card)

Col. 1-4		Printing Parameter for diagnostics	JCMSET
Col. 5-8	{	1 focal point in cartesian coordinates	JDCAM
		2 focal point in polar coordinates	
		3 automatic panning and zooming	
		4 automatic panning only	
		5 focal point in rectangular, parameters may vary	
		6 focal point in polar, parameters may change	
		7 automatic panning, zooming, parameters not re-initiated	
		8 automatic panning, parameters not re-initiated	
		9 focal point in rectangular, parameters not re-initiated	
		10 focal point in polar, parameters not re-initiated	

Col. 9-12	{ 1 picture printed as is 2 vertical axis reversed 3 horizontal axis reversed 4 both axis reversed (normal mode to compensate for camera inversion)	INVT
Col. 13-20	X-pos. of camera	SCRAT (1)
Col. 21-28	Y-pos. of camera	SCRAT (2)
Col. 29-36	Z-pos. of camera	SCRAT (3)
Col. 37-44	user defined (see NOTE)	SCRAT (4)
Col. 45-52	user defined (see NOTE)	SCRAT (5)
Col. 53-60	user defined (see NOTE)	SCRAT (6)
Col. 61-68	camera tilt angle	SCRAT (7)

NOTE:

- If JDCAM = 1,5 or 9
(focal point in rectangular coordinates)
 - SCRAT (4) - X component of focal point
 - SCRAT (5) - Y component of focal point
 - SCRAT (6) - Z component of focal point
 - SCRAT (7) - camera tilt angle

- If JDCAM = 2, 6 or 10
(focal point in polar coordinates)
 - SCRAT (4) - azimuth of camera's line-of-sight
 - SCRAT (5) - elevation of camera's line-of-sight
 - SCRAT (6) - focal length
 - SCRAT (7) - camera tilt angle

- If JDCAM = 3, 7, 4 or 8
(automatic panning and zooming)
 - SCRAT (4) - distance from CG to picture edge (not used JDCAM = 4, 8)
 - SCRAT (5) - distance from CG to center of picture
 - SCRAT (6) - focal length (not used JDCAM = 3, 7)
 - SCRAT (7) - camera tilt angle

For JDCAM = 5 through 10, the SCRAT values are changed each frame by some increment described by entries on the second camera card. The law that increments these values (like camera XYZ position) is obscure and the user is advised to study the manual thoroughly. The second camera card and the varying camera parameters concept seems to be useful when the user wishes the camera to act like a "chase car", accelerating alongside the moving bicycle.

(second camera card)

Col. 1-12	not used	
Col. (12J+1)-(12J+8) J=1,7	amount by which SCRAT(J) changes between frames	SCRAT (J+7)

Example: CAMERA CARDS

0	3	4	300.	1500.	-100.0	250.0	-60.0	0.00	0.0
1	2	3	4	5	6	7	8	9	10
11	12	13	14	15	16	17	18	19	20
21	22	23	24	25	26	27	28	29	30
31	32	33	34	35	36	37	38	39	40
41	42	43	44	45	46	47	48	49	50
51	52	53	54	55	56	57	58	59	60
61	62	63	64	65	66	67	68	69	70
71	72	73	74	75	76	77	78	79	80
0.	0.	0.	0.	0.	0.	0.	0.	0.	0.
1	2	3	4	5	6	7	8	9	10
11	12	13	14	15	16	17	18	19	20
21	22	23	24	25	26	27	28	29	30
31	32	33	34	35	36	37	38	39	40
41	42	43	44	45	46	47	48	49	50
51	52	53	54	55	56	57	58	59	60
61	62	63	64	65	66	67	68	69	70
71	72	73	74	75	76	77	78	79	80

4. BASIC DIMENSION CARDS

1st CARD

Col. 1-8	Caster angle (radians)	CASTER
Col. 9-16	Wheel size (inches)	WHSIZE

2nd CARD (All tie points in chassis coordinates)

Col. 1-10	X-coordinate (torso to chassis tie point)	XS
Col. 11-20	Y-coordinate (torso to chassis tie point)	YS
Col. 21-30	Z-coordinate (torso to chassis tie point)	ZS
Col. 31-40	Hunch angle (radians)	AH
Col. 41-50	X-coordinate (thigh to torso tie point-left)	XZL
Col. 51-60	Y-coordinate (thigh to torso tie point-left)	YZL
Col. 61-70	Z-coordinate (thigh to torso tie point-left)	ZZL
Col. 71-80	X-coordinate (thigh to torso tie point-right)	XZR

3rd CARD (All tie points in chassis coordinates, unless noted)

Col. 1-10	Y-coordinate (thigh to torso tie point-right)	YZR
Col. 11-20	Z-coordinate (thigh to torso tie point-right)	ZZR
Col. 21-30	Half foot distance	HF
Col. 31-40	X-coordinate (pedal to calf tie point-left) pedal axis	XPL
Col. 41-50	Y-coordinate (pedal to calf tie point-left) pedal axis	YPL
Col. 51-60	Z-coordinate (pedal to calf tie point-left) pedal axis	ZPL
Col. 61-70	X-coordinate (pedal to calf tie point-right) pedal axis	XPR
Col. 71-80	Y-coordinate (pedal to calf tie point-right) pedal axis	YPR

4th CARD (All tie points in torso axis coordinates, unless noted)

Col. 1-10	Z-coordinate (pedal to calf tie fornt-right) pedal axis	ZPR
Col. 11-20	X-coordinate (neck-shoulder point) not used	XXN
Col. 21-30	Y-coordinate (neck-shoulder point) not used	YYN
Col. 31-40	Z-coordinate (neck-shoulder point) not used	ZZN
Col. 41-50	X-coordinate (upper arm-shoulder tie point-right)	XXSR
Col. 51-60	Y-coordinate (upper arm-shoulder tie point-right)	YYSR
Col. 61-70	Z-coordinate (upper arm-shoulder tie point-right)	ZZSR
Col. 71-80	X-coordinate (upper arm-shoulder tie point-left)	XXSL

<u>5th CARD</u>	(All tie points in front fork axis coordinates, unless noted)	
Col. 1-10	Y-coordinate (upperarm to shoulder tie point-left) torso axis	YYSL
Col. 11-20	Z-coordinate (upperarm to shoulder tie point-left) torso axis	ZZSL
Col. 21-30	X-coordinate (forearm to handlebar tie point-right)	XXHR
Col. 31-40	Y-coordinate (forearm to handlebar tie point-right)	YYHR
Col. 41-50	Z-coordinate (forearm to handlebar tie point-right)	ZZHR
Col. 51-60	X-coordinate (forearm to handlebar tie point-left)	XXHL
Col. 61-70	Y-coordinate (forearm to handlebar tie point-left)	YYHL
Col. 71-80	Z-coordinate (forearm to handlebar tie point-left)	ZZHL
<u>6th CARD</u>	(All tie points in chassis coordinates, unless noted)	
Col. 1-10	Length of thigh (in.)	THIGH
Col. 11-20	Length of calf (in.)	CALF
Col. 21-30	Length of forearm (in.)	FA
Col. 31-40	Length of upperarm (in.)	UA
Col. 41-50	Arm pit angle (radians)	APIT
Col. 51-60	X-coordinate (pedal to chassis tie point)	XXP
Col. 61-70	Y-coordinate (pedal to chassis tie point)	YYP
Col. 71-80	Z-coordinate (pedal to chassis tie point)	ZZP
<u>7th CARD</u>	(All tie points in chassis coordinates)	
Col. 1-10	X-coordinate (front fork to chassis tie point)	XXF
Col. 11-20	Y-coordinate (front fork to chassis tie point)	YYF
Col. 21-30	Z-coordinate (front fork to chassis tie point)	ZZF

5. OBJECT DELETE CARDS

Col. 1-8 name of previously read in object that is to be
 released from storage (don't use WHEEL, REAREND, DAY
 CHASSIS)

.
 .
 .

Col. 1-80 blank specifies no more object delete cards

Note: This feature is useful if you use a new instruction card, etc. and want to eliminate some object plotted in the first part of the run. Remember to include a blank card even if there are no object delete cards!

6. OBJECT CARDS

(object title card)

Col. 1-8	title or name of object (blank implies no more cards)	TITL
Col. 9-16	{ 1 get new object title card	IT
	2 X, Y, Z parameters coming up	
	3 circle to be drawn coming up	
	4 circle's coordinates rectangular	
Col. 17-24	No. of points for upcoming specifications	IN
Col. 25-32	identification	ID

(object specification card) (These points will be connected by lines)
 If IT = 2 There are IN triplets of points or IN/2 cards

Col. 1-12	X-coordinate	DAT
Col. 13-24	Y-coordinate	DAT(J+1)
Col. 25-36	Z-coordinate	DAT(J+2)

Col. 37-48	X-coordinate	DAT (J+3)
Col. 49-60	Y-coordinate	DAT (J+4)
Col. 61-72	Z-coordinate	DAT (J+5)

(object specification cards)

If IT = 3 or 4 (draws a circle)

Col. 1-12	X-position of center of circle	SCRAT (1)
Col. 13-24	Y-position of center of circle	SCRAT (2)
Col. 25-36	Z-position of center of circle	SCRAT (3)
Col. 37-48	radius of circle	SCRAT (4)
Col. 49-56	azimuth of circle axis (degrees)	SCRAT (5)
Col. 57-64	elevation of circle axis (degrees)	SCRAT (6)
Col. 65-72	tilt of circle	SCRAT (7)

If the same object is not completely specified by the above title and specs, then an object type card followed by new spec. cards may be used.

(object type cards)

Col. 1-8	blank	
Col. 9-16	same IT as on title card	IT
Col. 17-24	same IN as on title card	IN

Notes:

- (1) Object specification cards define points that are to be connected together. Use object type cards to break up object into distinct line segments.
- (2) Last card in any object is an object type card with a 1 in columns 9-16.
- (3) Don't forget a blank card to indicate that there are no more object decks to be read in.

Example: A SIMPLE OBJECT

```

READ1          2          4
1 2 3 4 5 6 7 8 9 10 11 12 13 14 15 16 17 18 19 20 21 22 23 24 25 26 27 28 29 30 31 32 33 34 35 36 37 38 39 40 41 42 43 44 45 46 47 48 49 50 51 52 53 54 55 56 57 58 59 60 61 62 63 64 65 66 67 68 69 70 71 72 73 74 75 76 77 78 79 80
50.           -50.           -1.           -500.           -50.           -1.
1 2 3 4 5 6 7 8 9 10 11 12 13 14 15 16 17 18 19 20 21 22 23 24 25 26 27 28 29 30 31 32 33 34 35 36 37 38 39 40 41 42 43 44 45 46 47 48 49 50 51 52 53 54 55 56 57 58 59 60 61 62 63 64 65 66 67 68 69 70 71 72 73 74 75 76 77 78 79 80
-500.         50.           -1.           50.           50.           -1.
1 2 3 4 5 6 7 8 9 10 11 12 13 14 15 16 17 18 19 20 21 22 23 24 25 26 27 28 29 30 31 32 33 34 35 36 37 38 39 40 41 42 43 44 45 46 47 48 49 50 51 52 53 54 55 56 57 58 59 60 61 62 63 64 65 66 67 68 69 70 71 72 73 74 75 76 77 78 79 80
1
1 2 3 4 5 6 7 8 9 10 11 12 13 14 15 16 17 18 19 20 21 22 23 24 25 26 27 28 29 30 31 32 33 34 35 36 37 38 39 40 41 42 43 44 45 46 47 48 49 50 51 52 53 54 55 56 57 58 59 60 61 62 63 64 65 66 67 68 69 70 71 72 73 74 75 76 77 78 79 80
1 2 3 4 5 6 7 8 9 10 11 12 13 14 15 16 17 18 19 20 21 22 23 24 25 26 27 28 29 30 31 32 33 34 35 36 37 38 39 40 41 42 43 44 45 46 47 48 49 50 51 52 53 54 55 56 57 58 59 60 61 62 63 64 65 66 67 68 69 70 71 72 73 74 75 76 77 78 79 80

```

7. SKIP CARDS No. of skip entries = NSKIP

Col. 1-4 No. of consecutive runs to be skipped
 Col. 5-8 No. of consecutive runs to be processed
 Col. 9-12 No. of consecutive runs to be skipped
 Col. 13-16 No. of consecutive runs to be processed
 Etc.

default: no skips, 1 million runs processed.

Example: SKIP CARD (Processes the first run only on the dynamics tape)

0 1

1 2 3 4 5 6 7 8 9 10 11 12 13 14 15 16 17 18 19 20 21 22 23 24 25 26 27 28 29 30 31 32 33 34 35 36 37 38 39 40 41 42 43 44 45 46 47 48 49 50 51 52 53 54 55 56 57 58 59 60 61 62 63 64 65 66 67 68 69 70 71 72 73 74 75 76 77 78 79 80

8. PATTERN CARDS (Those objects that are to remain stationary during the run)

Col. 1-4	Pattern number	J
Col. 5-8	Leave blank	
Col. 9-16	Name of object to be printed on film	PATIN
Col. 17-20	Leave blank	
Col. 21-28	X-position of object in pattern	POSIN(1)
Col. 29-36	Y-position of object in pattern	POSIN(2)
Col. 37-44	Z-position of object in pattern	POSIN(3)
Col. 45-52	Euler angle phi	POSIN(4)
Col. 53-60	Euler angle theta	POSIN(5)
Col. 61-68	Euler angle psi	POSIN(6)

Notes:

- (1) If you don't use these pattern cards, then every object will undergo the same gyrations and maneuvers as the bicycle.
- (2) The POSIN values allow you, if desired, to plot an object several times at different locations.
- (3) Don't forget a blank card to indicate no more pattern cards.

Example: PATTERN CARDS

1 OFFRAMP

1 2 3 4 5 6 7 8 9 10 11 12 13 14 15 16 17 18 19 20 21 22 23 24 25 26 27 28 29 30 31 32 33 34 35 36 37 38 39 40 41 42 43 44 45 46 47 48 49 50 51 52 53 54 55 56 57 58 59 60 61 62 63 64 65 66 67 68 69 70 71 72 73 74 75 76 77 78 79 80

2 ONRAMP

1 2 3 4 5 6 7 8 9 10 11 12 13 14 15 16 17 18 19 20 21 22 23 24 25 26 27 28 29 30 31 32 33 34 35 36 37 38 39 40 41 42 43 44 45 46 47 48 49 50 51 52 53 54 55 56 57 58 59 60 61 62 63 64 65 66 67 68 69 70 71 72 73 74 75 76 77 78 79 80

3 ROAD1

1 2 3 4 5 6 7 8 9 10 11 12 13 14 15 16 17 18 19 20 21 22 23 24 25 26 27 28 29 30 31 32 33 34 35 36 37 38 39 40 41 42 43 44 45 46 47 48 49 50 51 52 53 54 55 56 57 58 59 60 61 62 63 64 65 66 67 68 69 70 71 72 73 74 75 76 77 78 79 80

4 ROAD2

1 2 3 4 5 6 7 8 9 10 11 12 13 14 15 16 17 18 19 20 21 22 23 24 25 26 27 28 29 30 31 32 33 34 35 36 37 38 39 40 41 42 43 44 45 46 47 48 49 50 51 52 53 54 55 56 57 58 59 60 61 62 63 64 65 66 67 68 69 70 71 72 73 74 75 76 77 78 79 80

5 ROAD3

1 2 3 4 5 6 7 8 9 10 11 12 13 14 15 16 17 18 19 20 21 22 23 24 25 26 27 28 29 30 31 32 33 34 35 36 37 38 39 40 41 42 43 44 45 46 47 48 49 50 51 52 53 54 55 56 57 58 59 60 61 62 63 64 65 66 67 68 69 70 71 72 73 74 75 76 77 78 79 80

1 2 3 4 5 6 7 8 9 10 11 12 13 14 15 16 17 18 19 20 21 22 23 24 25 26 27 28 29 30 31 32 33 34 35 36 37 38 39 40 41 42 43 44 45 46 47 48 49 50 51 52 53 54 55 56 57 58 59 60 61 62 63 64 65 66 67 68 69 70 71 72 73 74 75 76 77 78 79 80

The preceding cards are enough to run an elementary job with the Schwinn Bicycle Graphics Program. The last card in the input deck should be the STOP CARD, described with the IDENTIFICATION CARD.

There are two other card types, as yet untried by this author, that will be described below. They are not necessary to obtain a picture, but are optionally used for more complex movie generation.

PRE-RUN CARD if IPRUN 0

Col. 1-8	vehicle velocity with respect to fixed axis	V(1)
Col. 9-16	vehicle velocity with respect to fixed axis	V(2)
Col. 17-24	vehicle velocity with respect to fixed axis	V(3)
Col. 25-32	acceleration component	A(1)
Col. 33-40	acceleration component	A(2)
Col. 41-48	acceleration component	A(3)

Notes on PRE-RUN CARD:

The Pre-Run feature seems to allow the user to generate simple motion of chassis prior to the run from the dynamics tape. For example, if the dynamics tape has the chassis crossing a bridge, the PRE-RUN CARD can be used to simulate the approach to the bridge (even though that isn't on the tape). It is not clear what is the starting time of the Pre-Run sequence, but it is believed to be from 0 seconds to TB seconds.

CHANGE CARDS (only if lCHANG≠0)

(first change card)

Col. 1-6	time new sequence begins	TB
Col. 7-12	time new sequence ends	TE
Col. 13-18	{ 1 new time increment between frames 2 retain old time increment	TQ
Col. 19-22	{ 0 read no new camera cards 1 read new set of camera cards	ICAM
Col. 23-26	No. of frames used/subtitle printed	JTIT
Col. 27-30	{ 0 not expecting another set of change cards 1 new set of change cards expected	ICHANG
Col. 31-34	No. of lines of subtitles to be read	NOLINE
Col. 35-38	same as previously described	IPRUN
Col. 39-42	{ -1 draw sequence in same frame (double exposure) 0 no double exposure +1 double exposure in a different frame	IREP
Col. 43-46	{ -1 delete front end 0 no change 1 draw front end	IFR

Col. 47-50	{	-1	delete C.G. point	
		0	no change	ICG
		1	draw C.G. point	
Col. 51-54	{	0	delete printing of frame time	
		1	print frame time	LF

(second change card) SUBTITLE CARDS

Col. 1-4	No. of letters on subtitle	NOLET
Col. 5-12	X-position of starting point	XL
Col. 13-20	Y-position of starting point	YL
Col. 21-28	size of printed text	SL
Col. 29-76	characters or text to be printed	VERB

(third change card)

PATTERN CARDS

(fourth change card)

blank card to indicate no more pattern cards

(fifth change card)

CAMERA CHANGE CARDS

(sixth change card)

PRE-RUN CARD (if applicable)

Notes on CHANGE CARDS

CHANGE CARDS are used to change some simulation parameters during a run, such as switching to automatic panning or adding subtitles to a group of frames. It is worthy to note that a new identification card with associated data input deck can be processed also. This allows one continuous movie to be made from two tapes, etc.

Appendix IV

BICYCLE GRAPHICS PROGRAM LISTING

C \$\$\$

SCHWINN BICYCLE GRAPHICS PROGRAM

(MAIN)

C
C
C
C
C
C

DEVELOPED BY CORNELL AERONAUTICAL LABORATORY
P.O. BOX 235
BUFFALO, NEW YORK 14221

```
COMMON /COMDAT/LENGTH,NEXT,DAT(1999R)
DIMENSION JCHAS(611),SCRAT(14)
EQUIVALENCE (JCHAS(1),DAT(1))
COMMON/COMFRM/DUM(30),TANGLE,JEULER
EQUIVALENCE (XM,DUM(12)),(YM,DUM(13)),(FHIGH,DUM(9)),(CON,DUM(16))
COMMON/COMWHL/WHFEL(175)
COMMON /COMFRA/IFRAME
COMMON /COMSCR/LSCR,NOLET(12),XL(12),YL(12),SL(12),VFRB(12,12),
1 POSIN(6),DUMSCR(2)
COMMON/COMTRK/WCON(16),TWIDE,DOT
DIMENSION WC(3,4),IWC(4),JWC(4)
DIMENSION A(3,3),BJ(3,3),C(3,3),AB(5),AC(5)
DIMENSION TH(3,3),CF(3,3),FT(3,3),TL(3,3),TUAL(3,3),TUA(3,3),
1 FAL(3,3),TFA(3,3)
EQUIVALENCE (WC,WCON),(JWC,WCON(13))
REAL*8 TIME,CTIME2,TODAY,DAY,PATERN(50),PATIN,CTIME
REAL*8 BLANK/' '/,FNDG/'THE END '/
REAL*8 OWHEEL/'WHEEL '/,OCHAS/'CHASIS '/,ORFAR/'REAR END '/
REAL*4 LAMBDA,MHU,NHU
REAL*8 OFFORK/'FTFORK '/,OPEDAL/'PEDALS '/
REAL*8 ORTHGH/'RTHIGH '/, OLTGH/'LTHIGH '/
REAL*8 ORCALF/'RCALF '/, OLCALF/'LCALF '/
REAL*8 ORFOOT/'RFOOT '/, OLFoot/'LFOOT '/
REAL*8 OTORSO/'TORSO '/
REAL*8 ORUA/'RUARM '/, OLUa/'LUARM '/
REAL*8 ORFA/'RFARM '/, OLFA/'LFARM '/
REAL DENT(18),TITLE(36), VARO(14),CAM(7),CAMI(14)
1,PI2/1.5708/,STOP/4HSTOP /,START/4H**** /,CAMB(2),POS(6,50)
2 ,WRDT(4),XOLD(4),YOLD(4),TWOPI/6.28318/
INTEGER NSK(100),ITOLD/-2/,ICINT/1/,IPAT/0/,IOBJ/0/,IDCAM/0/,
1 LTIMEX/500/,ICSKP/0/,ITOLDA/-1/,JEFPLT/0/
COMMON /COMRUN/ VAR(14),VARN(14),IPRUN
EQUIVALENCE (VAR(1),T),(VAR(2),X),(VAR(3),Y),(VAR(4),Z),
1(VAR(5),PHI),(VAR(6),THETA),(VAR(7),PSI),(VAR(8),DELTA1),
2(VAR(9),DELTA2),(VAR(10),DELTA3),(VAR(11),ROLL),(VAR(12),STEER),
3 (VAR(13),CAMB(1)),(SCRAT(1),VERB(1,1)),(T9,VARN(1))
```

C
C

DIAGNOSTIC SWITCHES

```
COMMON/COMTST/ITEST(8)
INTEGER*2 ITEST,IHUB
EQUIVALENCE(IHUB,ITEST(1))
```

C

```
CALL ERRSET(209,100,3,2)
CALL PLOTTER(1)
CALL DATE(TODAY)
TIME = CTIME (0)
IANGLE = 0
JEULFR=0
```

C

IDENTIFICATION CARD

```
1 READ 2,DENT,ITEST
2 FORMAT (18A4, 8I1)
IF (JEFPLT.NE.0) GO TO 2009
LPEN=ITEST(2)
CALL PLTSET(LPEN)
```

```

JEFPLT=1
IF (LPEN.EQ.5) JEFPLT=2
2009 IF (DENT(1).NE.STOP)GO TO 1000
IF (ICSKP.EQ.0) GO TO 2005
PRINT 2004,ICSKP
2004 FORMAT ('0',I5,' INPUT CARDS IGNORED.')
```

ICSKP =0

```

2005 CONTINUE
PRINT 3,DENT,ITEST,TODAY,TIME
IF (DENT(2).NE.START) GO TO 2003
READ 15,JTIT
ASA = DUM(1)+1.0
PRINT 2001,JTIT,ASA
2001 FFORMAT ('0THE END IN',I4,' FRAMES STARTING WITH FRAME',F7.0)
DO 2002 J =1,JTIT
CALL FRAME
CALL SYMBOL(XM-C.2,YM-.3,0.5,0,0.0,1)
CALL SYMBOL(XM-C.3,YM+1.0,0.28,ENDG,0.0,7)
2002 CONTINUE
2003 CALL EFPLT(JEFPLT)
STOP
1000 IF(DENT(1).EQ.START) GO TO 1001
ICSKP=ICSKP+1
GO TO 1
1001 IF (ICSKP.NE.0) PRINT 2004,ICSKP
ICSKP=0
PRINT 3,DENT,ITEST,TODAY,TIME
3 FORMAT ('1',18A4,8I1,5X,A8,5X,A8/'OSVD MOVIE PROGRAM,CORNELL AFRON
1AUTICAL LABORATORY, FEB 70.')
```

C

```

INSTP. CARD
10 READ 11,WIDE,HIGH,TB,TF,DT,STDISP,EPST,IPRUN,IFR,ICG,
X ITRK,LF,ICAM,IREF,IFRAME,IT,
1 ICHAS,INIT,ICHANG,NSKIP,I0BC,ITIT,NTIT,STIT
11 FORMAT (7F6.0, 2I2,6I1,4I2,3I4,I2,F6.0)
T=TB
STDISQ = 0.4+4.0*STDISP
IF (WIDE.GT.0) CALL FRAMSZ(WIDE,HIGH)
WDZUM = AMINI(XM,YM)/25.4
IF (ITIT.LE.0) GO TO 1114
IF(NTIT.LE.0 ) NTIT =72
IF(STIT.LE.0.0) STIT =0.28
1101 MTIT =(80-NTIT)/8
J =(80+NTIT)/2 -4*MTIT
SCAL = STIT+STIT
1112 ASA =FHIGH - 14.0*SCAL
IF (ASA.GT.0.0) GO TO 1113
SCAL = SCAL- 0.07
GO TO 1112
1113 YCAL = (ASA+SCAL)/2.0
YDATE = YCAL + 3.0*SCAL
YTITA = YDATE+SCAL
YTITB = YTITA+SCAL
XCAL=XM-SCAL/2.0
1110 XTIT=XM-FLOAT(NTIT)*0.43*STIT
IF (XTIT.GT.0.0) GO TO 1111
STIT = STIT*0.9
GO TO 1110
1111 CONTINUE
XDATE= XM-3.44*STIT
NTIT = J
1114 PRINT12,WIDE,HIGH,TB,TF,DT,STDISP,EPST,IFR,ICG,ICAM,IREF,IFRAME,IT
```

```

1, ICHAS, INIT, ICHANG, NSKIP, IOBC, ITIT, NTIT, STIT, IPRUN, LF, ITRK
12  FORMAT ('OINSTRUCTION CARD'/ ' WIDE HIGH TB TE DT STDIS
1P EPST IFR ICG ICAM IREP IFRAME IT ICHAS INIT ICHANG NS
2KIP IOBC ITIT NTIT STIT'/1X,7F6.3,2I4,2I5,9I7,F7.3/
3 ' IPRUN = ',I3,', LF=',I3,', ITRK = ',I3)
IF(IT)1102,1201,1103
1201 PRINT 1202
1202 FORMAT ('ONO INPUT TAPE SPECIFIED.')
GO TO 2003
1102 IT = -IT
REWIND IT
ITOLDA = -2
GO TO 1104
1103 IF (ITOLD.EQ.IT) GO TO1
1104 ITOLD = -1
13 IF (ICAM.EQ.0) GO TO 17
C
14 NCAM = 0
1401 READ 15, JCMSET, JDCAM, INVT, SCRAT
15 FORMAT(3I4,7F8.0/12X,8F8.0)
IF (JDCAM.GT.2) GO TO 1410
1402 DO 1403 J=1,7
CAM(J) = SCRAT(J)
CAMI(J) = SCRAT(J)
1403 CAMI(J+7) = 0.0
ICMSET = JCMSET*2+JDCAM
IDCAM = JDCAM
CALL CAMSET(CAM,ICMSET,INVT)
TBCAM = TB
GO TO 1435
C
1410 IF(JDCAM.LT.7) GO TO 1420
ASB = TB -TBCAM
1412 DO 1414 J=1,7
CAMI(J) = CAMI(J)+ASB*CAMI(J+7)
1414 CAMI(J+7) = SCRAT(J+7)
IDCAM = JDCAM-4
GO TO 1425
1420 DO 1422 J=1,14
1422 CAMI(J) = SCRAT(J)
IDCAM=JDCAM
1425 TBCAM = TB
1430 ICMSET = 2*JCMSET+2-MOD(JDCAM,2)
1435 CONTINUE
PRINT 16, JCMSET, JDCAM, INVT, CAMI, TBCAM
16 FORMAT ('OCAMERA CARDS, ICMSET IDCAM INVT X Y
1 Z XF/AZ YF/EL ZF/FL TI TIME-CHANGE'
2 /15X,3I6,7F10.3/' DELTA VALUES',17X,8F10.3)
IF((JDCAM.GT.0).AND.(JDCAM.LT.11)) GO TO 1602
PRINT 1601
1601 FORMAT ('OILLEGAL CAMERA SET.')
GO TO 2003

1602 IF (NCAM.NE.0) GO TO 145
C
C
C
C BASIC DIM CARD
C
C NEW BASIC DIMENSION CARD FOR BICYCLE (CASTOR ANGLE,WHEEL SIZE)
C
17 READ 1603,CASTER,WHSIZE
1603 FORMAT(2F8.0)

```

```

19 READ 1604, XS,YS,ZS,AH,XZL,YZL,ZZL,XZR,YZR,ZZR,
1HF,XPL,YPL,ZPL,XPR,YPR,ZPR,XXN,YYN,ZZN,
2XXSR,YYSR,ZZSR,XXSL,YYSL,ZZSL,XXHR,YYHR,ZZHR,XXHL,
3YYHL,ZZHL,THIGH,CALF,FA,UA,APIT,XXP,YP,ZZP,XXF,YYF,ZZF
1604 FORMAT(8F10.0)
C
C
C INITIALIZE BICYCLE PARAMETERS.
C
OMEGA=0.
DIST=0.
XOLDX=C.
YOLDX=0.
ZOLDX=0.
C
C
C
1701 READ 1702, DAY
1702 FORMAT (9A8)
IF (DAY.EQ.BLANK) GO TO 1706
PRINT 1703
1703 FORMAT ('0OBJECTS DELETED. ')
1704 PRINT 1705, DAY
1705 FORMAT (5X,A8)
CALL DLT OBJ(DAY)
READ 1702, DAY
IF (DAY.NE.BLANK) GO TO 1704
1706 CONTINUE
18 IF (ICHAS.LE.0) GO TO 1801
ICINT =0
CALL DLT OBJ(ICHAS)
1801 IF (IORC.NE.0) IOBJ=0
C
1803 CALL OBJINP
20 IF (NSKIP.GT.0) GO TO 21
NSK(1) =0
NSK(2) = 100000
NSKIP = 2
GO TO 24
C
21 READ 22, (NSK(J), J=1, NSKIP)
22 FORMAT (16I4)
PRINT 23, (NSK(J), J=1, NSKIP)
23 FORMAT ('0SKIP NOS.', 16I5/(10X, 16I5))
24 CONTINUE
KPATN =1
C
2401 READ 2402, J, PATIN, POSIN
2402 FORMAT (I4, 4X, A8, 4X, 6F8.2)
IF (J) 2403, 2409, 2405
2403 J = -J
IF (J.GT.IOBJ) GO TO 2408
PRINT 2404, J, PATERN(J)
2404 FORMAT ('0DELETED PATTERN NO.', I4, 4X, A8)
PATERN(J)= BLANK
IF (J.EQ.IOBJ) IOBJ = IOBJ-1
GO TO 2401
2405 IF (J.GT.50) GO TO 2408
PATERN(J)=PATIN
DO 2406 K=1, 3
POS(K+3, J)=POSIN(K+3)*CON

```

```

2406 POS(K,J) = POSIN(K)
      PRINT 2407,J,PATIN,POSIN
2407 FORMAT ('OINPUT PATTERN',I4,4X,A8,6F12.3)
      IF (J.GT.IOBJ) IOBJ = J
      GO TO 2401
2408 PRINT 24091,J
24091 FORMAT ('OPATTERN IGNORED FOR J =',I4)
      GO TO 2401
2409 IF (KPATN.NE.1) GO TO 13901
2410 CONTINUE
      IF (ITOLDA.NE.IT) NRUN=0
      DO 400 JSKIP=1,NSKIP,2
      IF (NSK(JSKIP).LE.0) GO TO 27
      LOOP = NSK(JSKIP)
      DO 26 J=1,LOOP
      READ (IT,END=350)
25 READ (IT,END=350) T9
      IF (T.GT.(-999.0))GO TO 25
26 CONTINUE
      NRUN = NRUN+LOOP
27 LOOP = NSK(JSKIP+1)
      DO 400 JRUN=1,LOOP
      NRUN = NRUN+1
      IW = 1
C
      READ (IT,END=350) TITLE,DAY
      PRINT 28,DAY,TITLE
28 FORMAT ('O',A8,10X,18A4)
      DO 2801 J=1,4
2801 WROT(J)=0.0
      IF(ITRK.NE.0) CALL TRKSET
      TF2 = TF/2.0
      JPRUN=0
29 IF (ICINT.EQ.0) GO TO 2903
      IF (ICHAS.EQ.0) GO TO 2903
      CALL BLDCHS
2903 CONTINUE
      CALL CIRCLE (0.0,TWIDE,0.0,RW,90.0,0.0,0.0,WHEEL(22),24)
      JTIT = ITIT
35 CONTINUE
40 IF (JTIT.LE.0) GO TO 4101
      ASA = DUM(1)+1.0
      PRINT 4001,JTIT,ASA
4001 FORMAT ('OTITLE BLOCK IN',I4,' FRAMES STARTING IN FRAME NO.',F7.0)
      DO 41 J=1,JTIT
      CALL FRAME
      IF ((XCAL.LE.0.0).OR.(YCAL.LE.0.0)) GO TO 901
      CALL SYMBOL(XCAL,YCAL,SCAL,C,0.0,1)
      CALL SYMBOL(XDATE,YDATE,STIT,DAY,0.0,8)
901 IF (XTIT.LE.0.0) GO TO 41
      IF (YTITA.LE.0.0) GO TO 902
      CALL SYMBOL(XTIT,YTITA,STIT,TITLE(MTIT+18),0.0,NTIT)
902 IF (YTITB.LE.0.0) GO TO 41
      CALL SYMBOL(XTIT,YTITB,STIT,TITLE(MTIT ),0.0,NTIT)
41 CONTINUE
4101 IF (TB.GT.TE)GO TO 135
C
100 T=TB
      DYNAMIC PARAMETERS
110 READ (IT,END=349) VARN
      IF (VARN(1).LE.(-999.0)) GO TO 360
      JPRUN=JPRUN+1

```

```

11001 ASA = T-VARN(1)
      ASB = SIGN(1.0,ASA)
      IF (ABS(ASA).GE.EPST) GO TO 11003
      ASB=0.0
11002 IF((IPRUN.LT.0).AND.(ITRK.NE.0)) CALL PRUNRS
      IPRUN=0
      IW =-IW
      GO TO 111
11003 IF(ASB.GT.0.0) GO TO 11002
      IF(IPRUN.EQ.0) GOTO 11004
C
      CALL PRERUN
      IF (ITRK.NE.0) CALL TRKIN
      GO TO 116
11004 CONTINUE
      IF (IW.LE.0) GO TO 114
      T = T+DT
      GO TO 11001
111 DO 112 J=1,14
112 VAR(J) = VARN(J)
      IF(ITRK.NE.0)CALL TRKIN
      IF (ASB.NE.0.0 ) GO TO 110
      DO 113 J=2,14
113 VAR(J) = VARN(J)
      GO TO 116
114 DINT = (T-VAR(1))/(VARN(1)-VAR(1))
      DO 115 J=2,14
115 VAR(J) = VAR(J)+DINT*(VARN(J)-VAR(J))
116 CONTINUE
12210 IF (IDCAM.LE.2) GO TO 12222
      ASA = T-TBCAM
      DO 12212 J=1,7
12212 CAM(J) = CAMI(J)+ASA*CAMI(J+7)
      IF (IDCAM-4) 12214,12216,12218
C
      CAMCON = WDZOM/(WDZOM+CAM(4))
      CAM(6) = CAMCON*(CAM(5)-CAM(3))+CAM(3)
      CAM(5) = CAMCON*(VAR(3)-CAM(2))+CAM(2)
      CAM(4) = CAMCON*(VAR(2)-CAM(1))+CAM(1)
      GO TO 12220
C
      CAMCON = CAM(5)-CAM(3)
      ASX = VAR(2)-CAM(1)
      ASY = VAR(3)-CAM(2)
      ASZ = SQRT(ASX**2+ASY**2)
      CAM(4) = ATAN2(ASY,ASX)/DUM(16)
      CAM(5) = ATAN2(CAMCON,ASZ)/DUM(16)
      GO TO 12220
C
      CONTINUE
      CALL CAMSET(CAM,ICMSET,INVT)
12222 CONTINUE
      IF (IREP.LT.0) GO TO 12201
      CALL FRAME
      IF (STDISP.LE.0.0) GO TO 12201
      CALL SYMBOL (0.2,0.2,STDISP,'SEC.',0.0,4)
      CALL NUMBER(STDISQ,
                  0.2,STDISP,T,0.0,3)
12201 ASX = -B
      ASY = -RHO*SIN(ROLL)
      ASZ = ZR+RHO*COS(ROLL)+DELTA3
      IRT =0

```

```

C
C   CALCULATED DISTANCE TRAVELED, SPEED, WHEEL AND PEDAL ROTATION
C
2100 DIST=ABS(SQRT(((XOLDX-VARN(2))**2)+((YOLDX-VARN(3))**2)+
1((ZOLDX-VARN(4))**2)))
XOLDX=VARN(2)
YOLDX=VARN(3)
ZOLDX=VARN(4)
OMEGA = -.3*DIST/WHSIZE + OMEGA
AL = ROLL
C
C
C   LOADING OF BODY AXIS TO INERTIAL AXIS TRANSFORMATION MATRIX.
C
2101 A(1,1)=COS(PSI)*COS(THETA)
A(1,2)=-SIN(PSI)*COS(PHI)+COS(PSI)*SIN(THETA)*SIN(PHI)
A(1,3)=COS(PSI)*SIN(THETA)*COS(PHI)+SIN(PSI)*SIN(PHI)
A(2,1)=SIN(PSI)*COS(THETA)
A(2,2)=COS(PSI)*COS(PHI)+SIN(PSI)*SIN(THETA)*SIN(PHI)
A(2,3)=-COS(PSI)*SIN(PHI)+SIN(PSI)*SIN(THETA)*COS(PHI)
A(3,1)=-SIN(THETA)
A(3,2)=COS(THETA)*SIN(PHI)
A(3,3)=COS(THETA)*COS(PHI)
C
C   LOAD IN FRONT FORK TRANSFORMATION MATRIX
C
2102 BJ(1,1)=COS(CASTER)*COS(STEER)
BJ(1,2)=-COS(CASTER)*SIN(STEER)
BJ(1,3)=SIN(CASTER)
BJ(2,1)=SIN(STEER)
BJ(2,2)=COS(STEER)
BJ(2,3)=0.
BJ(3,1)=-SIN(CASTER)*COS(STEER)
BJ(3,2)=SIN(CASTER)*SIN(STEER)
BJ(3,3)=COS(CASTER)
C
C   LOAD IN PEDAL AXIS TRANSFORMATION MATRIX
C
2103 C(1,1)=COS(OMEGA)
C(1,2)=0.
C(1,3)=SIN(OMEGA)
C(2,1)=0.
C(2,2)=1.
C(2,3)=0.
C(3,1)=-SIN(OMEGA)
C(3,2)=0.
C(3,3)=COS(OMEGA)
2104 CALL OBJECT(OCHAS ,X,Y,Z,PHI,THETA,PSI)
C
C   TRANSFORMATION AND PLOTTING OF FRONT FORK STEERING AXIS.
C
C
C   DETERMINATION OF CENTER OF FRONT-FORK AXIS IN INERTIAL SPACE.
C
2105 XFFA = A(1,1)*XXF + A(1,2)*YYF + A(1,3)*ZZF + X
YFFA = A(2,1)*XXF + A(2,2)*YYF + A(2,3)*ZZF + Y
ZFFA = A(3,1)*XXF + A(3,2)*YYF + A(3,3)*ZZF + Z
C
C   DETERMINATION OF INERTIAL EULER ANGLES FOR THE FRONT-FORK AXIS.
C
2106 CALL EULER(A,BJ,THETA,PHI,PSI)

```



```

C
C   DRAW THE FRONT-FORK STEER AXIS SYSTEM
C
2108 CALL OBJECT(OFFORK,XFFA,YFFA,ZFFA,PHIF,THETAF,PSIF)
C
C   TRANSFORMATION AND PLOTTING OF PEDAL AXIS.
C
C   DETERMINATION OF CENTER OF PEDAL AXIS.
C
2109 XPA = A(1,1)*XXP + A(1,2)*YYP + A(1,3)*ZZP + X
      YPA = A(2,1)*XXP + A(2,2)*YYP + A(2,3)*ZZP + Y
      ZPA = A(3,1)*XXP + A(3,2)*YYP + A(3,3)*ZZP + Z
C
C   DETERMINATION OF INERTIAL FULER ANGLES FOR PEDAL AXIS
C
2110 CALL EULER(A,C,THETAP,PHIP,PSIP)
C
C   DRAW THE PEDAL AXIS SYSTEM
C
2112 CALL OBJECT(OPEDAL ,XPA,YPA,ZPA,PHIP,THETAP,PSIP)
C
C
C   PLOT THE RIDER LEAN ACTION
C
      TL(1,1) = COS(AH)
      TL(1,2) = SIN(AH)*SIN(AL)
      TL(1,3) = -SIN(AH)*COS(AL)
      TL(2,1) = 0.
      TL(2,2) = COS(AL)
      TL(2,3) = 0.
      TL(3,1) = SIN(AH)
      TL(3,2) = -COS(AH)*SIN(AL)
      TL(3,3) = COS(AH)*COS(AL)
      XXS= A(1,1)*XS + A(1,2)*YS + A(1,3)*ZS + X
      YYS= A(2,1)*XS + A(2,2)*YS + A(2,3)*ZS + Y
      ZZS= A(3,1)*XS + A(3,2)*YS + A(3,3)*ZS + Z
      CALL EULER(A,TL,THETAL,PHIL,PSIL)
      CALL OBJECT(OTORSO,XXS,YYS,ZZS,PHIL,THETAL,PSIL)
C
C           PLACEMENT AND PLOTTING OF LEGS
C
C
      KOUNT = 1
C
C   CALCULATION OF POINT X IN CHASSIS COORDINATES
C
1500 GO TO (1605,1606),KOUNT
1605 XX = COS(OMEGA)*XPL + SIN(OMEGA)*ZPL + XXP
      YX = YPL + YYP
      ZX = -SIN(OMEGA)*XPL + COS(OMEGA)*ZPL + ZXP
      GO TO 1607
1606 XX = COS(OMEGA)*XPR + SIN(OMEGA)*ZPR + XXP
      YX = YPR + YYP
      ZX = -SIN(OMEGA)*XPR + COS(OMEGA)*ZPR + ZXP
1607 CONTINUE
C
C   CALCULATION OF POINT Y IN CHASSIS COORDINATES
C

```

```

1610 GO TO (1611,1612),KOUNT
1611 ATOE = -.25*COS(OMEGA)
      GO TO 1613
1612 ATOE = .25*COS(OMEGA)
1613 CONTINUE
      XY = XX - COS(ATOE)*HF
      YY = YX
      ZY = ZX - SIN(ATOE)*HF
C
C   CALCULATION OF POINT Q IN CHASSIS COORDINATES
C
1620 GO TO (1621,1622),KOUNT
1621 DZY=SQRT((XZL-XY)*(XZL-XY)+(YZL-YY)*(YZL-YY)+(ZZL-ZY)*(ZZL-ZY))
      AA = ATAN2((XY-XZL),(ZY-ZZL))
      P = .5*(DZY+THIGH+CALF)
      R = SQRT(((P-DZY)*(P-THIGH)*(P-CALF))/P)
      ACJ = 2.*ATAN2(R,P-CALF)
      AD = 2.*ATAN2(R,P-THIGH)
      ABJ = 1.5707-AA
      AACJ = 1.5708 - AA - ACJ
      AQ = ABJ + AD
      XQ = THIGH*SIN(AA+ACJ)+XZL
      YQ = YZL
      ZQ = THIGH*COS(AA+ACJ)+ZZL
      GO TO 1623
1622 DZY=SQRT((XZR-XY)*(XZR-XY)+(YZR-YY)*(YZR-YY)+(ZZR-ZY)*(ZZR-ZY))
      AA = ATAN2((XY-XZL),(ZY-ZZL))
      P = .5*(DZY+THIGH+CALF)
      R = SQRT(((P-DZY)*(P-THIGH)*(P-CALF))/P)
      ACJ = 2.*ATAN2(R,P-CALF)
      AD = 2.*ATAN2(R,P-THIGH)
      ABJ = 1.5707-AA
      AACJ = 1.5708 - AA - ACJ
      AQ = ABJ + AD
      XQ = THIGH*SIN(AA+ACJ) + XZR
      YQ = YZR
      ZQ = THIGH*COS(AA+ACJ) + ZZR
1623 CONTINUE
C
C   DRAW THE THIGH
C
1630 GO TO (1631,1632),KOUNT
1631 XLT = A(1,1)*XZL + A(1,2)*YZL + A(1,3)*ZZL + X
      YLT = A(2,1)*XZL + A(2,2)*YZL + A(2,3)*ZZL + Y
      ZLT = A(3,1)*XZL + A(3,2)*YZL + A(3,3)*ZZL + Z
      GO TO 1633
1632 XRT = A(1,1)*XZR + A(1,2)*YZR + A(1,3)*ZZR + X
      YRT = A(2,1)*XZR + A(2,2)*YZR + A(2,3)*ZZR + Y
      ZRT = A(3,1)*XZR + A(3,2)*YZR + A(3,3)*ZZR + Z
1633 CONTINUE
      TH(1,1) = COS(AACJ)
      TH(1,2) = 0.
      TH(1,3) = -SIN(AACJ)
      TH(2,1) = 0.
      TH(2,2) = 1.
      TH(2,3) = 0.
      TH(3,1) = SIN(AACJ)
      TH(3,2) = 0.
      TH(3,3) = COS(AACJ)
      CALL EULER(A,TH,THETAT,PHIT,PSIT)
1640 GO TO (1641,1642),KOUNT

```

```

1641 CALL OBJECT(ORTHGH,XLT,YLT,ZLT,PHIT,THETAT,PSIT)
GO TO 1643
1642 CALL OBJECT(OLTHGH,XRT,YRT,ZRT,PHIT,THETAT,PSIT)
1643 CONTINUE
C
C   DRAW THE CALF
C
XC = A(1,1)*XQ + A(1,2)*YQ + A(1,3)*ZQ + X
YC = A(2,1)*XQ + A(2,2)*YQ + A(2,3)*ZQ + Y
ZC = A(3,1)*XQ + A(3,2)*YQ + A(3,3)*ZQ + Z
CF(1,1) = COS(AQ)
CF(1,2) = 0.
CF(1,3) = -SIN(AQ)
CF(2,1) = 0.
CF(2,2) = 1.
CF(2,3) = 0.
CF(3,1) = SIN(AQ)
CF(3,2) = 0.
CF(3,3) = COS(AQ)
CALL EULER(A,CF,THETAC,PHIC,PSIC)
1650 GO TO (1651,1652),KOUNT
1651 CALL OBJECT(OLCALF,XC,YC,ZC,PHIC,THETAC,PSIC)
GO TO 1653
1652 CALL OBJECT(ORCALF,XC,YC,ZC,PHIC,THETAC,PSIC)
1653 CONTINUE
C
C   DRAW THE FOOT
C
XXX = A(1,1)*XX + A(1,2)*YX + A(1,3)*ZX + X
YYX = A(2,1)*XX + A(2,2)*YX + A(2,3)*ZX + Y
ZZX = A(3,1)*XX + A(3,2)*YX + A(3,3)*ZX + Z
FT(1,1) = COS(ATOE)
FT(1,2) = 0.
FT(1,3) = -SIN(ATOE)
FT(2,1) = 0.
FT(2,2) = 1.
FT(2,3) = 0.
FT(3,1) = SIN(ATOE)
FT(3,2) = 0.
FT(3,3) = COS(ATOE)
CALL EULFR(A,FT,THETOE,PHITOE,PSITOE)
1660 GO TO (1661,1662),KOUNT
1661 CALL OBJECT(OLFOOT,XXX,YYX,ZZX,PHITOE,THETOE,PSITOE)
GO TO 1663
1662 CALL OBJECT(ORFOOT,XXX,YYX,ZZX,PHITOE,THETOE,PSITOE)
1663 CONTINUE
C
C   PLOT THE RIDER STEER ACTION
C
C
C   DETERMINE POINTS HR,HL,SR,SL IN CHASSIS COORDINATES
C
GO TO (6020,6021), KOUNT
6020 XSL = TL(1,1)*XXSL + TL(1,2)*YYSL + TL(1,3)*ZZSL + XS
YSL = TL(2,1)*XXSL + TL(2,2)*YYSL + TL(2,3)*ZZSL + YS
ZSL = TL(3,1)*XXSL + TL(3,2)*YYSL + TL(3,3)*ZZSL + ZS
XHL = BJ(1,1)*XXHL + BJ(1,2)*YYHL + BJ(1,3)*ZZHL + XXF
YHL = BJ(2,1)*XXHL + BJ(2,2)*YYHL + BJ(2,3)*ZZHL + YFF
ZHL = BJ(3,1)*XXHL + BJ(3,2)*YYHL + BJ(3,3)*ZZHL + ZFF
GO TO 6022

```

```

6021 XSR = TL(1,1)*XXSR + TL(1,2)*YYSR + TL(1,3)*ZZSR + XS
      YSR = TL(2,1)*XXSR + TL(2,2)*YYSR + TL(2,3)*ZZSR + YS
      ZSR = TL(3,1)*XXSR + TL(3,2)*YYSR + TL(3,3)*ZZSR + ZS
      XHR = BJ(1,1)*XXHR + BJ(1,2)*YYHR + BJ(1,3)*ZZHR + XXF
      YHR = BJ(2,1)*XXHR + BJ(2,2)*YYHR + BJ(2,3)*ZZHR + YFF
      ZHR = BJ(3,1)*XXHR + BJ(3,2)*YYHR + BJ(3,3)*ZZHR + ZZF

```

```

6022 CONTINUE

```

```

C

```

```

C      DETERMINE THE ELBOW POINTS IN CHASSIS AXIS COORDINATES
C

```

```

C

```

```

      GO TO (6030,6031), KOUNT

```

```

C

```

```

C      LEFT SIDE

```

```

6030 U = XHL-XSL
      V = YHL-YSL
      W = ZHL-ZSL
      DSHL = SQRT(U**2+V**2+W**2)
      LAMBDA = U/DSHL
      MHU = V/DSHL
      NHU = W/DSHL
      AYAW = ATAN2(MHU,LAMBDA)
      WHU = SQRT(LAMBDA**2 + MHU**2)
      APITCH = -ATAN2(NHU,WHU)
      DQE = SQRT(UA**2 - (DSHL/2.)**2)
      XEP = 0.
      YEP = -DQE*COS(APIT)
      ZEP = DQE*SIN(APIT)
      XQL = .5*(XSL+XHL)
      YQL = .5*(YSL+YHL)
      ZQL = .5*(ZSL+ZHL)
      TUA(1,1) = COS(AYAW)*COS(APITCH)
      TUA(1,2) = -SIN(AYAW)
      TUA(1,3) = COS(AYAW)*SIN(APITCH)
      TUA(2,1) = SIN(AYAW)*COS(APITCH)
      TUA(2,2) = COS(AYAW)
      TUA(2,3) = SIN(AYAW)*SIN(APITCH)
      TUA(3,1) = -SIN(APITCH)
      TUA(3,2) = 0.
      TUA(3,3) = COS(APITCH)
      XEL = TUA(1,1)*XEP + TUA(1,2)*YEP + TUA(1,3)*ZEP + XQL
      YEL = TUA(2,1)*XEP + TUA(2,2)*YEP + TUA(2,3)*ZEP + YQL
      ZEL = TUA(3,1)*XEP + TUA(3,2)*YEP + TUA(3,3)*ZEP + ZQL
      GO TO 6032

```

```

C

```

```

C      RIGHT SIDE

```

```

6031 U = XHR-XSR
      V = YHR-YSR
      W = ZHR-ZSR
      DSHR = SQRT(U**2+V**2+W**2)
      LAMBDA = U/DSHR
      MHU = V/DSHR
      NHU = W/DSHR
      AYAW = ATAN2(MHU,LAMBDA)
      WHU = SQRT(LAMBDA**2+MHU**2)
      APITCH = -ATAN2(NHU,WHU)
      DQE = SQRT(UA**2 - (DSHR/2.)**2)
      XEP = 0.
      YEP = DQE*COS(APIT)
      ZEP = DQE*SIN(APIT)
      XQR = .5*(XSR+XHR)
      YQR = .5*(YSR+YHR)

```

```

ZQR = .5*(ZSR+ZHR)
TUA(1,1) = COS(AYAW)*COS(APITCH)
TUA(1,2) = -SIN(AYAW)
TUA(1,3) = COS(AYAW)*SIN(APITCH)
TUA(2,1) = SIN(AYAW)*COS(APITCH)
TUA(2,2) = COS(AYAW)
TUA(2,3) = SIN(AYAW)*SIN(APITCH)
TUA(3,1) = -SIN(APITCH)
TUA(3,2) = 0.
TUA(3,3) = COS(APITCH)
XER = TUA(1,1)*XEP + TUA(1,2)*YEP + TUA(1,3)*ZEP + XQR
YER = TUA(2,1)*XEP + TUA(2,2)*YEP + TUA(2,3)*ZEP + YQR
ZER = TUA(3,1)*XEP + TUA(3,2)*YEP + TUA(3,3)*ZEP + ZQR
6032 CONTINUE
C
C   PLOT THE UPPER ARMS
C
GO TO (2020,2021), KOUNT
2020 LAMBDA = (XEL-XSL)/UA
MHU = (YEL-YSL)/UA
NHU = (ZEL-ZSL)/UA
WHU = SQRT(LAMBDA**2+MHU**2)
AYAW = ATAN2(MHU,LAMBDA)
APITCH = -ATAN2(NHU,WHU)
GO TO 2023
2021 LAMBDA = (XER-XSR)/UA
MHU = (YER-YSR)/UA
NHU = (ZER-ZSR)/UA
WHU = SQRT(LAMBDA**2+MHU**2)
AYAW = ATAN2(MHU,LAMBDA)
APITCH = -ATAN2(NHU,WHU)
2023 CONTINUE
TUA(1,1) = COS(AYAW)*COS(APITCH)
TUA(1,2) = -SIN(AYAW)
TUA(1,3) = COS(AYAW)*SIN(APITCH)
TUA(2,1) = SIN(AYAW)*COS(APITCH)
TUA(2,2) = COS(AYAW)
TUA(2,3) = SIN(AYAW)*SIN(APITCH)
TUA(3,1) = -SIN(APITCH)
TUA(3,2) = 0.
TUA(3,3) = COS(APITCH)
XSLF = A(1,1)*XSL + A(1,2)*YSL + A(1,3)*ZSL + X
YSLF = A(2,1)*XSL + A(2,2)*YSL + A(2,3)*ZSL + Y
ZSLF = A(3,1)*XSL + A(3,2)*YSL + A(3,3)*ZSL + Z
XSRF = A(1,1)*XSR + A(1,2)*YSR + A(1,3)*ZSR + X
YSRF = A(2,1)*XSR + A(2,2)*YSR + A(2,3)*ZSR + Y
ZSRF = A(3,1)*XSR + A(3,2)*YSR + A(3,3)*ZSR + Z
CALL EULER(A,TUA,THETUA,PHIUA,PSIUA)
GO TO (2010,2011), KOUNT
2010 CALL OBJECT(OLUA,XSLF,YSLF,ZSLF,PHIUA,THETUA,PSIUA)
GO TO 2012
2011 CALL OBJECT(ORUA,XSRF,YSRF,ZSRF,PHIUA,THETUA,PSIUA)
2012 CONTINUE
C
C   PLOT THE FOREARMS
C
GO TO (2025,2026), KOUNT
2025 LAMBDA = (XHL-XEL)/FA
MHU = (YHL-YEL)/FA
NHU = (ZHL-ZEL)/FA

```

```

      WHU = SQRT(LAMBDA**2+MHU**2)
      AYAW = ATAN2(MHU,LAMBDA)
      APITCH = -ATAN2(NHU,WHU)
      GO TO 2027
2026 LAMBDA = (XHR-XER)/FA
      MHU = (YHR-YER)/FA
      NHU = (ZHR-ZER)/FA
      WHU = SQRT(LAMBDA**2+MHU**2)
      AYAW = ATAN2(MHU,LAMBDA)
      APITCH = -ATAN2(NHU,WHU)
2027 CONTINUE
      TFA(1,1) = COS(AYAW)*COS(APITCH)
      TFA(1,2) = -SIN(AYAW)
      TFA(1,3) = COS(AYAW)*SIN(APITCH)
      TFA(2,1) = SIN(AYAW)*COS(APITCH)
      TFA(2,2) = COS(AYAW)
      TFA(2,3) = SIN(AYAW)*SIN(APITCH)
      TFA(3,1) = -SIN(APITCH)
      TFA(3,2) = 0.
      TFA(3,3) = COS(APITCH)
      XELF = A(1,1)*XEL + A(1,2)*YEL + A(1,3)*ZEL + X
      YELF = A(2,1)*XEL + A(2,2)*YEL + A(2,3)*ZEL + Y
      ZELF = A(3,1)*XEL + A(3,2)*YEL + A(3,3)*ZEL + Z
      XERF = A(1,1)*XER + A(1,2)*YER + A(1,3)*ZER + X
      YERF = A(2,1)*XER + A(2,2)*YER + A(2,3)*ZER + Y
      ZERF = A(3,1)*XER + A(3,2)*YER + A(3,3)*ZER + Z
      CALL FULEK(A,TFA,THETFA,PHIFA,PSIFA)
      GO TO (2030,2031), KOUNT
2030 CALL OBJECT(OLFA,XELF,YELF,ZELF,PHIFA,THETFA,PSIFA)
      GO TO 2032
2031 CALL OBJECT(ORFA,XERF,YERF,ZERF,PHIFA,THETFA,PSIFA)
2032 CONTINUE
      KOUNT = KOUNT + 1
      IF (KOUNT-3) 1500,1700,1700
1700 CONTINUE
      IF (LF.NE.0) PRINT 12501,DUM(1),T
12501 FORMAT (' VEHICLE IN FRAME',F5.0,' AT TIME', F10.4)
127  IF (ITRK.EQ.0) GO TO 12701
      CALL TRACK
      IF (IREP.NE.0) CALL TRKSET
12701 IF (IREP) 130,128,12702
12702 IREP=-1
128  IF (IOBJ.LE.0) GO TO 130
      DO 129 J=1,IOBJ
2113 CALL OBJECT(PATERN(J),POS(1,J),POS(2,J),POS(3,J),POS(4,J),POS(5,J)
1,POS(6,J))
129  CONTINUE
130  T = T+DT
      IF (T.LF.TE) GO TO 11001
      IF ((ITRK.NE.0).AND.(IREP.LT.0)) CALL TRACK
      T=T-DT
C
      CHANGE CARD(S)
135  IF (ICHANG.LE.0) GO TO 390
      IF (ICHANG.GT.NRUN) GO TO 390
      READ 136,TB,TE,QT,ICAM,JTIT,ICHANG,NCLINE,IPRUNA,IREP,IFR,ICG ,LF
136  FORMAT (3F6.0,9I4)
      IF (JPRUN.GT.1) GO TO 13601
      IPRUN=IPRUNA
13601 PRINT 137,TB,TE,QT,ICAM,JTIT,ICHANG,NCLINE,IPRUN,IREP,IFR,ICG,LF
137  FORMAT ('OCHANGE CARD' 3F8.3,9I4)
      IF (ICINT.EQ.0) GO TO 13706

```

```

      IF (IFR) 13701,13703,13702
13701 JCHAS(116) = 4
      JCHAS(117) = 169
      GO TO 13703
13702 JCHAS(116) = 2
      JCHAS(117) = 21
13703 IF (ICG) 13704,13706,13705
13704 JCHAS(287) = 1
      GO TO 13706
13705 JCHAS(287) = 2
13706 CONTINUE
      IF (JTIT.LE.0) GO TO 139
C
      PRINT 138
      SUBTITLE CARDS
138  FORMAT ('NOLET      X          Y          Z          SCALE      SUBTITLE.')
      DO 13804 L=1,NOLINE,12
      JLINE = MINO(12,NOLINE-L+1)
      DO 13803 K=1,JLINE
      READ 13801,NOLET(K),XL(K),YL(K),SL(K),(VERB(J,K),J=1,12)
13801 FORMAT (I4,3F8.3,12A4)
      PRINT 13802,NOLET(K),XL(K),YL(K),SL(K),(VERB(J,K),J=1,12)
13802 FORMAT(2X,I4,3F8.3,5X,12A4)
13803 CONTINUE
      ASA = DUM(1)+1.0
      PRINT 13805,JTIT,ASA
13805 FORMAT ('SUBTITLE BLOCK IN',I4,' FRAMES STARTING WITH FRAME NO.',
1 F7.0)
      DO 13804 J=1,JTIT
      IF (IRFP.EQ.0) CALL FRAME
      DO 13804 K=1,JLINE
      IF ((XL(K).LT.0.0).OR.(YL(K).LT.0.0).OR.(SL(K).LE.0.0).OR.
1 (NOLET(K).LT.0)) GO TO 13804
      IF ((NOLET(K).GT.48).OR.(NOLET(K).EQ.0)) NOLET(K)=48
      CALL SYMBOL(XL(K),YL(K),SL(K),VERB(1,K),0.0,NOLET(K))
13804 CONTINUE
139  KPATN =2
      GO TO 2401
13901 IF (ICAM.EQ.0) GO TO 145
C
      NCAM = 1
      GO TO 1401
      CAMERA CHANGE CARD
145  IF (QT.LE.0.0) GO TO 14501
      DT=QT
14501 CONTINUE
      IF (KPATN.NE.2) GO TO 355
      IF (ABS(T-TB).LE.EPST) GO TO 146
      T=TB
14502 IF(T.GE.VARO(1)) GO TO 11001
      T=T+DT
      GO TO 14502
146  T=TB+DT
      GO TO 11001
349  CALL SECTION
350 PRINT 351,IT
351 FORMAT ('END OF FILE ON DATA SET',I3,' ALL INPUT CARDS SKIPEO TO
NEXT IDENTIFICATION CARD.')
      ITOLD = IT
      GO TO 1
355  IF ((IPRUNA.GT.0).AND.(JPRUN.EQ.1)) READ 1702,ASA
360  IF (ICHANG.LE.0) GO TO 390
      IF (ICHANG.GT.NRUN) GO TO 390

```

```

READ I36,TB,TF,DT,ICAM,JTIT,ICHANG,NCLINE,JPRUNA
IF (JTIT.LE.0) GO TO 362
DO 361 J=1,NOLINE
READ I3801,K
361 CONTINUE
362 KPATN =3
GO TO 2401
390 CALL SECTON
IF ((JSKIP.EQ.(NSKIP-1)).AND.(JRUN.EQ.LOOP)) GO TO 400
391 IF(T9.LE.(-999.0)) GO TO 400
READ(IT,FND=350) T9
GO TO 391
400 CONTINUE
GO TO 1
END
SUBROUTINE EULER(A,B,THETA,PHI,PSI)
DIMENSION A(3,3),B(3,3),AB(5)
25 AB(1) = A(1,1)*B(1,1) + A(1,2)*B(2,1) + A(1,3)*B(3,1)
AB(2) = A(2,1)*B(1,1) + A(2,2)*B(2,1) + A(2,3)*B(3,1)
AB(3) = A(3,1)*B(1,1) + A(3,2)*B(2,1) + A(3,3)*B(3,1)
AB(4) = A(3,1)*B(1,2) + A(3,2)*B(2,2) + A(3,3)*B(3,2)
AB(5) = A(3,1)*B(1,3) + A(3,2)*B(2,3) + A(3,3)*B(3,3)
30 IF ((AB(4).EQ.0.).AND.(AB(5).EQ.0.)) GO TO 100
31 IF ((AB(5).EQ.0.).OR.(ABS(AB(4)/AB(5))).GT.1.677E07) GO TO 100
32 PHI = ATAN2(AB(4),AB(5))
33 IF ((AB(2).EQ.0.).AND.(AB(1).EQ.0.)) GO TO 100
34 IF ((AB(1).EQ.0.).OR.(ABS(AB(2)/AB(1))).GT.1.677E07) GO TO 100
35 PSI = ATAN2(AB(2),AB(1))
37 IF ((SIN(PSI).EQ.0.).OR.(ABS(-AB(3)/(AB(2)/SIN(PSI)))).GT.1.677E07
1.OR.(AB(1).EQ.0.)) GO TO 100
36 IF ((-AB(3).EQ.0.).AND.((AB(2)/SIN(PSI)).EQ.0.)) GO TO 100
38 THETA = ATAN2(-AB(3),(AB(2)/SIN(PSI)))
RETURN
100 THETA = -ARSIN(AB(3))
PHI = ARSIN(AB(4)/COS(THETA))
150 PSI = ARSIN(AB(2)/COS(THETA))
RETURN
END
C$$$ SUBROUTINE FRAME, SECTON, FRAMSZ
C THIS FORTRAN DECK ORIGINALLY PRODUCED AS PART OF
C THE SINGLE VEHICLE ACCIDENT MOVIE PROGRAM (PART A)
C (RELEASE DATE, SEPT.12,1968)
C
C DEVELOPED BY CALVIN M. THEISS
C TRANSPORTATION RESEARCH DEPT.
C CORNELL AERONAUTICAL LABORATORY
C BUFFALO, NEW YORK 14221
C
SUBROUTINE FRAME
COMMON/COMFRM/FRNO,XFR(5),YFR(5),XM,YM,USED,SECT,CON,D,FXP,FYP,
1 FZP,CA,CE,SA,SE,CACE,SASE,SACF,CASE,CT,ST,IANGLE,JEULER
DATA IFRSW/1/
EQUIVALENCE (HIGH,YFR(3)),(WIDE,XFR(3))
COMMON /COMFRA/IFRAME
COMMON/PENLOC/PENDUM(7),LPEN
C
GO TO (20,10,10,15),LPEN
10 CALL PLOT(0,0,0)
GO TO 30
15 CALL PLOT(0,0,-3)
GO TO 30

```



```

C
20  IF (IFRSW.FQ.0) GO TO 21
    IFRSW = 0
    YUBS = 1.0
    XPES = WIDE
    YRES = HIGH
    FRNU = 0.0
    USED = USED + XRES
    GO TO 30
21  IF ((YOBS+YRES+HIGH) .GT.28.) GO TO 23
    IF (XRES.GE.WIDE) GO TO 22
    USED = USED-XRES+WIDE
    XRES = WIDE
22  CALL PLOT(0.0,YRES+1.0,-3)
    YOBS = YOBS+YRES+1.0
    YRES = HIGH
    GO TO 30
23  CALL PLOT (      XRES+1.0,      -YOBS+1.0,-3)
    YOBS = 1.0
    XRES = WIDE
    YRES = HIGH
    USED = USED+XRES+1.0
30  FRNU = FRNU+1.0
    CALL PLOT(0.0,1.5,-3)
    IF (IFRAME.NE.0) CALL LINE(XFR,YFR,5,1)
    RETURN
C
    ENTRY SECTION
    PRINT 34,SECT,FRNU
34  FORMAT ('END OF SECTION',2F8.0,' FRAMES')
    FRNU=0.0
    SECT = SECT+1.0
    IF (LPEN.NE.1) RETURN
35  USED = USED+1.0
    PRINT 36,USED
36  FORMAT('C',F10.2,' INCHES OF PLOTTING PAPER USED.')
    CALL PLOT(      XRES+1.0,      -YOBS+1.0,-3)
    USED = 1.0
    IFRSW = 2
    RETURN
C
    ENTRY FRAMSZ(/WIDTH/,/HEIGHT/)
42  WIDE = WIDTH
    HIGH = HEIGHT
    XFR(2) = WIDE
    YFR(4) = HIGH
    XM = WIDE/2.0
    YM = HIGH/2.0
    RETURN
C
    ENTRY LEADER (/LEAD/)
100 L=LEAD
    IF(L.LE.0) RETURN
    GO TO (140,110,110,120),LPEN
110 K=0
    GO TO 130
120 K=-3
130 DO131 J=1,L
    CALL PLOT(0,0,K)
131 CONTINUE
    PRINT 132,L

```

```

132  FORMAT ('OLEADER FRAMES',I6)
140  RETURN
      END
C****          CHASIS BUILDING ROUTINE DUMMY
      SUBROUTINE BLDCHS
1      PRINT 2
2      FORMAT('OCALL TO SUBR. BLDCHS., ONLY DUMMY EXISTS. JOB TERMINATE
ID')
      CALL EFPLOT
      STOP 1
      END
C$$$          FUNCTION IEDGE
C          THIS FORTRAN DECK ORIGINALLY PRODUCED AS PART OF
C          THE SINGLE VEHICLE ACCIDENT MOVIE PROGRAM (PART A)
C          (RELEASE DATE, SEPT.12,1968)
C
C          DEVELOPED BY CALVIN M. THEISS
C          TRANSPORTATION RESEARCH DEPT.
C          CORNELL AERONAUTICAL LABORATORY
C          BUFFALO, NEW YORK 14221
C
      FUNCTION IEDGE(/O/)
C          DEFINITION OF PICTURE PLANE AREAS
C          0  INSIDE FRAME
C          1  OUTSIDE FRAME, RIGHT CENTRAL
C          2  OUTSIDE FRAME, UPPER RIGHT
C          3  OUTSIDE FRAME, UPPER CENTRAL
C          4          UPPER LEFT
C          5          LEFT CENTRAL
C          6          LOWER LEFT
C          7          LOWER CENTRAL
C          8  OUTSIDE FRAME, LOWER RIGHT
C
C          A IS START POINT, B IS END POINT
COMMON/COMFRM/FRNO,XFR(5),YFR(5),XM,YM,USED,SECT,CON,D,FXP,FYP,
1 FZP,CA,CE,SA,SE,CACE,SASE,SACE,CASE,CT,ST,IANGLE,JEULER
COMMON /COMEDG/ XO(20),YO(20),XA,XB,DENX,DENY,YA,YB
COMMON /COMSET/NSETS,XFLIP,YFLIP,FNL,EPS
1 IF(XA.LT.XM) GO TO 6
  IF(XB.GT.XM) GO TO 200
  IF(YA.LT.YM) GO TO 3
  IF(YB.GT.YM) GO TO 200
C
C          A IN 2, B IN 5,6,7
      XO(1) = XM
      CALL YF(1)
      IF(YO(1).LT.YM) GO TO 2
      YO(1) = YM
      CALL XF(1)
      IF(XO(1).LE.(-XM)) GO TO 200
      XO(2) = -XM
      CALL YF(2)
      IF(YO(2).GE.(-YM)) GO TO 100
      YO(2) = -YM
      CALL XF(2)
      GO TO 100
2 IF(YO(1).LE.(-YM)) GO TO 200
  XO(2) = -XM
  CALL YF(2)
  IF(YO(2).GE.(-YM)) GO TO 100
  YO(2) = -YM
  CALL XF(2)

```

```

GO TO 100
3 IF (YA.GT.(-YM)) GO TO 5
  IF (YB.LT.(-YM)) GO TO 200
C
  X0(1) = XM
  CALL YF(1)
  IF(Y0(1).GE.(-YM)) GO TO 4
  Y0(1) = -YM
  CALL XF(1)
  IF (X0(1).LE.(-XM)) GO TO 200
301 X0(2) = -XM
  CALL YF(2)
  IF(Y0(2).LE.YM) GO TO 100
  Y0(2) = YM
  CALL XF(2)
  GO TO 100
4 IF (Y0(1).GE.YM) GO TO 200
  GO TO 301
C
  X0(1) = XM
  CALL YF(1)
  IF(ABS(Y0(1)).GE.YM) GO TO 200
  X0(2) = -XM
  CALL YF(2)
  IF (ABS(Y0(2)).LE.YM) GO TO 100
  Y0(2) = SIGN(YM,Y0(2))
  CALL XF(2)
  GO TO 100
6 IF (XA.GT.(-XM)) GO TO 11
  IF (XB.LT.(-XM)) GO TO 200
  IF (YA.LT.YM) GO TO 8
  IF (YB.GT.YM) GO TO 200
C
  X0(1) = -XM
  CALL YF(1)
  IF (Y0(1).LT.YM) GO TO 7
  Y0(1) = YM
  CALL XF(1)
  IF (X0(1).GE.XM) GO TO 200
  X0(2) = XM
  CALL YF(2)
  IF (Y0(2).GE.(-YM)) GO TO 100
  Y0(2) = -YM
  CALL XF(2)
  GO TO 100
7 IF (Y0(1).LE.(-YM)) GO TO 200
  X0(2) = XM
  CALL YF(2)
  IF (Y0(2).GE.(-YM)) GO TO 100
  Y0(2) = -YM
  CALL XF(2)
  GO TO 100
8 IF (YA.GT.(-YM)) GO TO 10
  IF (YB.LE.(-YM)) GO TO 200
C
  X0(1) = -XM
  CALL YF(1)
  IF (Y0(1).GE.(-YM)) GO TO 9
  Y0(1) = -YM
  CALL XF(1)
  IF (X0(1).GE.XM) GO TO 200

```

```

XO(2) = XM
CALL YF(2)
IF (YO(2).LE.YM) GO TO 100
YO(2) = YM
CALL XF(2)
GO TO 100
9 IF (YO(1).GE.YM) GO TO 200
XO(2) = XM
CALL YF(2)
IF (YO(2).LE.YM) GO TO 100
YO(2) = YM
CALL XF(2)
GO TO 100
C
10 XO(1) = -XM
CALL YF(1)
IF (ABS(YO(1)).GE.YM) GO TO 200
XO(2) = XM
CALL YF(2)
IF (ABS(YO(2)).LE.YM) GO TO 100
YO(2) = SIGN(YM,YO(2))
CALL XF(2)
GO TO 100
11 IF (YA.LT.YM) GO TO 12
IF (YB.GE.YM) GO TO 200
C
YO(1) = YM
CALL XF(1)
IF (ABS(XO(1)).GE.XM) GO TO 200
YO(2) = -YM
CALL XF(2)
IF (ABS(XO(2)).LE.XM) GO TO 100
XO(2) = SIGN(XM,XO(2))
CALL YF(2)
GO TO 100
12 IF (YB.LE.(-YM)) GO TO 200
C
YO(1) = -YM
CALL XF(1)
IF (ABS(XO(1)).GE.XM) GO TO 200
YO(2) = YM
CALL XF(2)
IF (ABS(XO(2)).LE.XM) GO TO 100
XO(2) = SIGN(XM,XO(2))
CALL YF(2)
C
100 IEDGE = 2
IF (NSETS.GT.0) PRINT 101,XO(1),YO(1),XO(2),YO(2)
101 FORMAT (' LINE CENTER ONLY IN, ',4F12.3)
RETURN
C
200 IEDGE = 0
RETURN
END
C$$$ SUBROUTINE CIRCLE
C THIS FORTRAN DECK ORIGINALLY PRODUCED AS PART OF
C THE SINGLE VEHICLE ACCIDENT MOVIE PROGRAM (PART A)
C (RELEASE DATE, SEPT.12,1968)
C
C DEVELOPED BY CALVIN M. THEISS
C TRANSPORTATION RESEARCH DEPT.

```

C
C
C

CORNELL AERONAUTICAL LABORATORY
BUFFALO, NEW YORK 14221

```
SUBROUTINE CIRCLE(/X/,/Y/,/Z/,/R/,/AZ/,/EL/,/TI/,P,/NOP/)
COMMON /COMFRM/ DUM(15),CON, DUMA(14), IANGLE, IEULER
DATA PI2/6.28185/
DIMENSION P(1000)
NOPTS = NOP
1 DA = PI2/FLOAT(NOPTS)
  A = TI*CON
  DO 2 J=1,NOPTS
    P(J) = R*COS(A)
    P(J+NOPTS+1) = R*SIN(A)
  2 A = A+DA
    A=CON*EL
    CE = COS(A)
    SE = SIN(A)
    A=CON*AZ
    CA = COS(A)
    SA = SIN(A)
    CASE = CA*SE
    SASE = SA*SE
    DO 11 J=1,NOPTS
      A = -P(J)*SA-P(J+NOPTS+1)*CASE
      P(J+2*NOPTS+2) = P(J+NOPTS+1)*CE+Z
      P(J+NOPTS+1) = P(J)*CA-P(J+NOPTS+1)*SASE+Y
    11 P(J) = A+X
      P(NOPTS+1) = P(1)
      P(2*NOPTS+2) = P(NOPTS+2)
      P(3*NOPTS+3) = P(2*NOPTS+3)
      RETURN
      END
SUBROUTINE PLTSET
RETURN
END
C$$$ SUBROUTINE TRACK
SUBROUTINE TRACK
COMMON/COMTRK/WCON(16),TWIDE,DOT
DIMENSION WC(3,4), JWC(4),LC(4)
1 , S(3,4),DS(3),X(20),Y(20),Z(20)
EQUIVALENCE (WC,WCON),(JWC,WCON(13))
REAL WH(3,4,100),XYZ(20,3)
INTEGER IW(4),IR(4),IS(4),IWH*2(4,100),NMAX/100/
EQUIVALENCE (XYZ,X),(XYZ(1,2),Y),(XYZ(1,3),Z)
1 CALL OBAXIS(0,0,0,0,0,0)
DO 15 J=1,4
  IF(IW(J).EQ.0) GO TO 15
  IF (IW(J).EQ.IS(J)) GO TO 15
  IR(J)= IS(J)
2002 K=IR(J)
  IC=IWH(J,K)
  DO 2001 L=1,3
2001 XYZ(1,L)=WH(L,J,K)
2003 CONTINUE
  DO 4 L=2,20
    IR(J)= IR(J)+1
    IF(IR(J).GT.NMAX) IR(J)=1
    K=IR(J)
    ID=IWH(J,K)
  DO 3 N=1,3
3 XYZ(L,N)=WH(N,J,K)
```

```

        IF (IC.NE.ID) GO TO 5
        IF (IR(J).EQ.IW(J)) GO TO 5
4      CONTINUE
        L = 20
5      IF (IC) 6,7,8
6      CALL OBLINE(X,Y,Z,L)
7      IF (IR(J).EQ.IW(J)) GO TO 15
7002  X(1) = X(L)
        Y(1) = Y(L)
        Z(1) = Z(L)
7001  IC = ID
        GO TO 2003
8      DO 9      N=2,L,2
        CALL OBLINE(X(N-1),Y(N-1),Z(N-1),2)
9      CONTINUE
        IF (IR(J).EQ.IW(J)) GO TO 15
        IF (MOD(L,2).NE.0) GO TO 7002
        IF (ID.LT.0) GO TO 7002
        IR(J)=IR(J)+1
        IF (IR(J).EQ.IW(J)) GO TO 15
        IF (IR(J).GT.NMAX) IR(J)=1
        GO TO 2002
15     CONTINUE
        RETURN
C
        ENTRY TRKSET
100    DO 101  J=1,4
        LC(J)= 0
        IW(J)=0
        IR(J)=0
101    IS(J)=1
        DOT2=DOT**2
        EPS=0.01*DOT2
        RETURN
C
        ENTRY TRKIN
110    DO 120  J=1,4
        IF (LC(J).NE.0) GO TO 115
        IF (JWC(J).EQ.0) GO TO 120
        IF (IW(J).NE.0) GO TO 111
        IW(J)=1
        NR=0
        GO TO 11102
111    NR=0
11101  IW(J)=IW(J)+1
        IF (IW(J).GT.NMAX) IW(J)=1
        IF (IS(J).NE.IW(J)) GO TO 11102
        IS(J)=IS(J)+1
        IF (IS(J).GT.NMAX) IS(J)=1
11102  K=IW(J)
        IF (NR.NE.0) GO TO 11902
        IWH(J,K)=JWC(J)
        DO 11103 L=1,3
11103  WH(L,J,K)=WC(L,J)
        LC(J) = JWC(J)
        DO 112 L=1,3
112    S(L,J)= WC(L,J)
        GO TO 120
115    D=0.0
        DO 116 L=1,3
        DS(L)=WC(L,J)-S(L,J)

```

```

116  D=D+DS(L)**2
      A=D-DOT2
      IF (A) 11901,111,11601
11601 IF (LC(J).LT.0) GO TO 111
      IF(ABS(A).LT.EPS) GO TO 111
      D=DOT/SQRT(D)
      R=D
      DO 117 L=1,3
117  DS(L)= DS(L)*D
118  DO 119 L=1,3
119  S(L,J)=S(L,J)+DS(L)
      NR=1
      GO TO 11101
11902 IWH(J,K)= LC(J)
      DO 11903 L=1,3
11903 WH(L,J,K)=S(L,J)
      R=R+D
      IF(R-1.0) 118,111,11901
11901 IF (LC(J).NE.JWC(J)) GO TO 111
120  CONTINUE
      RETURN
      END

```

```

C$$$      SUBROUTINE PRERUN
C          THIS FORTRAN DECK ORIGINALLY PRODUCED AS PART OF
C          THE SINGLE VEHICLE ACCIDENT MOVIE PROGRAM (PART C)
C
C          DEVELOPED BY CALVIN M. THEISS
C          TRANSPORTATION RESEARCH DEPT.
C          CORNELL AERONAUTICAL LABORATORY
C          BUFFALO, NEW YORK 14221
C

```

```

SUBROUTINE PRERUN
COMMON/COMTRK/WCON(16),TWIDE,DOT
DIMENSION WC(3,4),IWC(4),JWC(4)
EQUIVALENCE (WC,WCON),(JWC,WCON(13))
COMMON /COMRUN/ VAR(14),VARN(14),IPRUN
EQUIVALENCE (T,VAR(1))
REAL V(3),A(3),SAVE(3,4)
1  IF (IPRUN.LT.0) GO TO 10
   IPRUN=-1
   READ 2,V,A
2  FORMAT (9F8.2)
   PRINT 3,V,A
3  FORMAT ('OPRE-RUN VELOCITIES =',3F10.4,' ACCELERATIONS =',3F10.4)
4  DO 5 J=1,3
5  A(J)=A(J)/2.0
   DO 6 K=1,4
   DO 6 J=1,3
6  SAVE(J,K)=WC(J,K)
10 TT=VARN(1)-T
   DO 11 J=1,3
   TT= (A(J)*TT+V(J))*TT
   VARN(J+1)=VARN(J+1)-TT
   DO 11 K=1,4
11 WC(J,K)=SAVE(J,K)-TT
   DO 12 J=5,14
12 VAR(J)= VARN(J)
   RETURN
C
ENTRY PRUNRS
DO 20 K=1,4

```

```

DO 20 J=1,3
20   WC(J,K)=SAVE(J,K)
RETURN
END

```

```

C$$$      BLOCK DATA, SVA MOVIE PART B
C          THIS FORTRAN DECK ORIGINALLY PRODUCED AS PART OF
C          THE SINGLE VEHICLE ACCIDENT MOVIE PROGRAM (PART B)
C
C          DEVELOPED BY CALVIN M. THEISS
C                      TRANSPORTATION RESEARCH DEPT.
C                      CORNELL AERONAUTICAL LABORATORY
C                      BUFFALO, NEW YORK 14221
C
C          AMMENDED FOR SCHWINN BICYCLE MOVIE   SEPT. 1971
C
C

```

```

BLOCK DATA
COMMON /COMDAT/LENGTH,NEXT
DATA NEXT/1/,LENGTH/19998/

```

```

COMMON /COMDAT/ SPARE(19998)

```

```

COMMON /COMDAT/ SPARE(19998)
DATA SPARE/19998*0./

```

```

COMMON /COMWHL/WHEEL(2),IWA(19),W( 75),IWC(2),WC(75),IWB(2)
DATA WHEEL/'WHEEL  '/,IWA/175,2*2,6*0,2*2,6*0,2,25/,IWB/5,1/,
1 IWC/2,25/,W/7*0.0/,WC/75*0.0/

```

```

COMMON/COMSCR/LSCR,SCRAT(200)
DATA LSCR/200/
END

```

```

C$$$      SUBROUTINE OBJECT
C          THIS FORTRAN DECK ORIGINALLY PRODUCED AS PART OF
C          THE SINGLE VEHICLE ACCIDENT MOVIE PROGRAM (PART B)
C
C          DEVELOPED BY CALVIN M. THEISS
C                      TRANSPORTATION RESEARCH DEPT.
C                      CORNELL AERONAUTICAL LABORATORY
C                      BUFFALO, NEW YORK 14221
C
C

```

```

SUBROUTINE OBJECT(TITLE ,X,Y,Z,PHI,THETA,PSI)
COMMON /COMDAT/LENGTH,NEXT,DAT(19998)
COMMON/COMFRM/FRNO,XFR(5),YFR(5),XM,YM,USED,SECT,CON,D,FXP,FYP,
1 FZP,CA,CE,SA,SE,CACE,SASE,SACE,CASE,CT,ST,IANGLE,JEULER
EQUIVALENCE (HIGH,YFR(3)),(WIDE,XFR(3))
COMMON /COMSCR/LSCR,SCRAT(1)
DIMENSION TITLE(2),IDAT(1),ISCRAT(1),TITL(2),TITLD(2)
EQUIVALENCE (DAT(1),IDAT(1)),(SCRAT(1),ISCRAT(1))
DATA BLANK/4H  /

```

```

1 J = 1
2 IF(TITLE(1).NE.DAT(J)) GO TO 3
IF(TITLE(2).EQ.DAT(J+1)) GO TO 10
3 J = IDAT(J+2) + J
IF (J.LT.NEXT) GO TO 2
PRINT 4, TITLE,FRNO
4 FORMAT (' OBJECT '2A4,' NOT AVAILABLE FOR FRAME'F8.0)
RETURN
10 CALL OBRAXIS(X,Y,Z,PHI,THETA,PSI)
1010 ITYPE = IDAT(J+3)
GO TO (14,20,30,40,50), ITYPE

```



```

12 PRINT 13, ITYPE, TITLE, FRNO
13 FORMAT (' TYPE'I4, ' NOT RECOGNIZED FOR OBJECT '2A4, ' IN FRAME'
1 F8.0)
14 RETURN
C          STRAIGHT LINES
20 NOPTS = IDAT(J+4)
CALL OBLINE(DAT(J+5), DAT(J+NOPTS+5), DAT(J+2*NOPTS+5), NOPTS)
J = J+3*NOPTS+2
GO TO 1010
C          CIRCLE
30 NOPTS = IDAT(J+4) + 1
JJ=3*NOPTS
IF (LSCR.GT.JJ) GO TO 32
PRINT 31, LSCR, JJ, TITLE
31 FORMAT (' OCOMMON COMSCR CONTAINS', I6, ' WORDS, SUBR. CIRCLE REQUIR
IES', I6, ' FOR OBJECT ', 2A4)
STOP
32 CONTINUE
CALL CIRCLE (DAT(J+6), DAT(J+7), DAT(J+8), DAT(J+4), DAT(J+9),
1 DAT(J+10), SCRAT, IDAT(J+5))
CALL OBLINE (SCRAT(1), SCRAT(NOPTS+1), SCRAT(2*NOPTS+1), NOPTS)
J = J+8
GO TO 1010
C          NON-USED SECTION
40 J=J+IDAT(J+4)+2
GO TO 1010
50 J=J+1
GO TO 1010
C
ENTRY OBJINP
101 READ 102, TITL ,IT, IN, ID
102 FORMAT (2A4, 3I8)
IF (TITL (1).EQ.BLANK) RETURN
IF((NEXT+4).LT.LENGTH) GO TO 105
103 PRINT 104, TITL
104 FORMAT (' OINSUFFICIENT SPACE LEFT FOR OBJECT ' 2A4)
STOP
105 NOWDS = 3
DAT(NEXT) = TITL (1)
DAT(NEXT+1) = TITL (2)
KLEN = NEXT+3
GO TO 108
106 READ 107, IT, IN, ID
107 FORMAT (8X, 3I8)
108 GO TO (109, 110, 120, 120, 140 ), IT
GO TO 140
109 IDAT(NEXT+2) = NOWDS+1
IDAT(KLEN) = 1
PRINT 10901, DAT(NEXT), DAT(NEXT+1), NEXT, IDAT(NEXT+2)
10901 FORMAT (' OOBJECT (' , 2A4, ') AT LOC.', I6, ' OF COMDAT WITH', I6,
1 ' WORDS.')
NEXT=KLEN+1
GO TO 101
C          STRAIGHT LINES
110 K = 3*IN+2
IF((KLEN+K).GT.LENGTH) GO TO 103
IDAT(KLEN) = 2
KLEN = KLEN+1
IDAT(KLEN) = IN
KLEN2 = KLEN+IN
KLEN3 = KLEN2+IN

```

```

        READ 111, (DAT(KLEN+J), DAT(KLEN2+J), DAT(KLEN3+J), J=1, IN)
111  FORMAT (6F12.1)
        IF (ID.EQ.0) GO TO 113
        KLEN2=KLEN+1
        KLEN3=KLEN3+IN
        DO 112 J=KLEN2, KLEN3
112  DAT(J)=DAT(J)*12.0
113  CONTINUE
        KLEN = KLEN+K-1
        NCWDS= NCWDS+K
        GO TO 106

C          CIRCLE
120  READ 121, (SCRAT(J), J=1, 7)
121  FORMAT (4F12.1, 3F8.1)
        IF (ID.EQ.0) GO TO 12102
        DO 12101 J=1, 4
12101 SCRAT(J)=SCRAT(J)*12.0
12102 CONTINUE
        IF (IT.NE.3) GO TO 130
        IF ((KLEN+ 9).GT.LENGTH) GO TO 103
        NCWDS = NCWDS+9
        IDAT(KLEN) = 3
        KLEN = KLEN+1
        IDAT(KLEN) = IN
        DO 122 J=1, 7
122  DAT(KLEN+J) = SCRAT(J)
        KLEN = KLEN+8
        GO TO 106

C          SETTING UP CIRCLE MATRIX IN COMDAT
130  NW = 3*IN+5
        IF ((KLEN+NW ).GT.LENGTH) GO TO 103
        IDAT(KLEN) = 2
        IDAT(KLEN+1) = IN +1
        KLEN = KLEN+2
        CALL CIRCLE(SCRAT(1), SCRAT(2), SCRAT(3), SCRAT(4), SCRAT(5), SCRAT(6),
1  SCRAT(7), DAT(KLEN), IN)
        KLEN = NW-2+KLEN
        NCWDS = NCWDS+NW
        GO TO 106
140  PRINT 141, IT, TITL
141  FORMAT ('OYPE', I4, ' NOT RECOGNIZED IN OBJECT ' 2A4)
        STOP

C          ENTRY          DLT OBJ(TITLD)
201  K = 1
202  IF (K.LT.NEXT) GO TO 204
        PRINT 203, TITLD
203  FORMAT ('OOBJECT ', 2A4, ' TO BE DELETED, IS NON-EXISTANT.')
        RETURN
204  IF (TITLD(1).NE.DAT(K)) GO TO 205
        IF (TITLD(2).EQ.DAT(K+1)) GO TO 210
205  K = K + IDAT(K+2)
        GO TO 202
210  J = IDAT(K+2)
        PRINT 21010, TITLD, J
21010 FORMAT ('OOBJECT (' 2A4, ') WITH', I6, ' WORDS DELETED.')
        J=J+K
211  DAT(K) = DAT(J)
        IF (J.GE.NEXT) GO TO 212
        J = J+1
        K = K+1

```

```

GO TO 211
212 NEXT = K
RETURN
END

C$$$      BLOCK DATA, SVA MOVIE PART A
C          THIS FORTRAN DECK ORIGINALLY PRODUCED AS PART OF
C          THE SINGLE VEHICLE ACCIDENT MOVIE PROGRAM (PART A)
C          (RELEASE DATE, SEPT.12,1968)
C
C          DEVELOPED BY CALVIN M. THEISS
C          TRANSPORTATION RESEARCH DEPT.
C          CORNELL AERONAUTICAL LABORATORY
C          BUFFALO, NEW YORK 14221
C
BLOCK DATA
COMMON/COMFRM/FRNO,XFR(5),YFR(5),XM,YM,USED,SECT,CON,D,FXP,FYP,
1 FZP,CA,CE,SA,SE,CACE,SASE,SACE,CASE,CT,ST,IANGLE,JEULER
DATA FRNO/0.0/,XFR/0.0,10.0,10.0,0.0,0.0/,YFR/0.0,0.0,7.12,7.12,
1 0.0/,USED/0.0/,CON/0.0174533/,XM/5.0/,YM/3.56/,SECT/1.0/,
2 IANGLE,JEULER/1,1/,D,FXP,FYP,FZP,CA,CE,SA,SE,CACE,SASE,SACE,
3 CASE,CT,ST/24.0,0.0947,2*0.0,2*1.0,2*0.0,1.0,3*0.0,1.0,0.0/

C
COMMON /COMSET/NSETS,XFLIP,YFLIP,ENL,EPS
DATA NSETS/-3/,XFLIP/1.0/,YFLIP/1.0/,ENL,EPS/25.4,0.05/

C
COMMON /COMFRA/IFRAME
DATA IFRAME/1/
END

C$$$      SUBROUTINE INITAL
C          THIS FORTRAN DECK ORIGINALLY PRODUCED AS PART OF
C          THE SINGLE VEHICLE ACCIDENT MOVIE PROGRAM (PART C)
C
C          DEVELOPED BY CALVIN M. THEISS
C          TRANSPORTATION RESEARCH DEPT.
C          CORNELL AERONAUTICAL LABORATORY
C          BUFFALO, NEW YORK 14221
C
SUBROUTINE INITAL(/I/,/AA/)
COMMON /COMDAT/LENGTH,NEXT,DAT(19998)
COMMON /COMWHL/ WHEEL(175)
DIMENSION IREAR(50),IWHEEL(50)
EQUIVALENCE (REAR(1),IREAR(1)),(WHEEL(1),IWHEEL(1))
COMMON/COMTRK/WCON(16),TWIDE,DOT
DIMENSION WC(3,4),IWC(4),JWC(4)
EQUIVALENCE (WC,WCON),(JWC,WCON(13))
DATA ISW/1/
1 IF (I.EQ.0) GO TO 3
READ 2,WHEEL(6),DL,REAR(24),REAR(25),TOPIN,TWIDE,DOT
2 FORMAT(9F8.0)
PRINT 201,WHEEL(6),DL,REAR(32),REAR(33),TOPIN,TWIDE,DOT
201 FORMAT ('0BASIC DIM. ',9F12.3)
REAR(6)=DL/2.0
TWIDE = TWIDE/2.0
GO TO 10
3 IF (ISW.EQ.0) RETURN
DOT =12.0
TWIDE = 3.0
TOPIN = 3.0
WHEEL(6)=4.0
REAR(6)=4.0
REAR(24)=0.625

```

```

REAR(25)=3.0
10 WHEEL(7)=-WHEEL(6)
WHEEL(18)=WHEEL(6)
WHEEL(19)=WHEEL(7)
REAR(15)=-REAR(6)
DO 12 J=7,14
REAR(J)=REAR(6)
12 REAR(J+9)=REAR(15)
REAR(28) = -REAR(24)
RFAR(29) = -REAR(25)
REAR(26) = REAR(25)
REAR(27) = REAR(24)
REAR(30) = REAR(29)
REAR(31) = REAR(28)
REAR(32) = REAR(24)
REAR(42) = REAR(29)
REAR(43) = REAR(28)
REAR(44) = REAR(24)
REAR(45) = REAR(25)
REAR(46) = REAR(25)
REAR(47) = REAR(24)
REAR(48) = REAR(28)
REAR(49) = REAR(29)
REAR(50) = REAR(29)
REAR(148)= REAR(25)
DO 13 J=1,9
REAR(J+32)=REAR(J+23)
13 REAR(J+50)=REAR(J+41)
K=1
DO 14 J=1,50,8
IREAR(J+59)=2
IREAR(J+60)=2
REAR(J+61) =REAR(15)
REAR(J+62) =REAR(6)
RFAR(J+63) =REAR(K+24)
REAR(J+64) =REAR(K+24)
REAR(J+65) =REAR(K+42)
REAR(J+66) =REAR(K+42)
14 K=K+1
DO 15 J=4,21
15 REAR(J+148)=WHEEL(J)
DO 16 J=1,175
16 WHEEL(J)=WHEEL(J)
AA=TOPIN
ISW =0
RETURN
END

```

```

C$$$      SUBROUTINE OBLINE, OBAXIS
C          THIS FORTRAN DECK ORIGINALLY PRODUCED AS PART OF
C          THE SINGLE VEHICLE ACCIDENT MOVIE PROGRAM (PART A)
C          (RELEASE DATE, SEPT.12,1968)
C
C          DEVELOPED BY CALVIN M. THEISS
C          TRANSPORTATION RESEARCH DEPT.
C          CORNELL AERONAUTICAL LABORATORY
C          BUFFALO, NEW YORK 14221
C

```

```

SUBROUTINE OBLINE(X,Y,Z,/NOPT/)
COMMON/COMFRM/FRNO,XFR(5),YFR(5),XM,YM,USED,SECT,CON,D,FXP,FYP,
1 FZP,CA,CE,SA,SE,CACE,SASE,SACE,CASE,CT,ST,IANGLE,JFULER
EQUIVALENCE (HIGH,YFR(3)),(WIDE,XFR(3))

```

```

COMMON /COMEDG/ X0(20),Y0(20),XA,XB,DENX,DENY,YA,YB
REAL X(1),Y(1),Z(1)
INTEGER IDEN(6)/6*0/
INTEGER JEDGE/0/
COMMON /COMSFT/NSETS,XFLIP,YFLIP,ENL,FPS
DATA XX,YY,ZZ,XY,XZ,YX,YZ,ZX,ZY,XOR,YOR,ZOR/3*1.0,9*0.0/
COMMON/COMFRA/IFRAME
DIMENSION XS(20),YS(20)

C
  IF(NSETS.LT.0) GO TO 100
  PRINT 901,XM,YM
901  FORMAT(' OBLINE CENTER',2F10.4)
  PRINT 903,(X(M),Y(M),Z(M),M=1,NOPT)
903  FORMAT (7X,6F12.3)
100  J = 0
  L = 0
  IBACK=0
  N = NOPT
101  DO 180 K=1,N
  J = J+1
  DX = XOR+X(K)*XX+Y(K)*YX+Z(K)*ZX
  DY = YOR+X(K)*XY+Y(K)*YY+Z(K)*ZY
  DZ = ZOR+X(K)*XZ + Y(K)*YZ+Z(K)*ZZ
800  XP = DX*CAF+DY*SACE+DZ*SE-FXP
  YP = DY*CA-DX*SA-FYP
  ZP = DZ*CF-DX*CASE-DY*SASE-FZP
  IF (XP.GT.EPS) GO TO 810
  IF (IBACK.EQ.0) GO TO 802
801  XPOLD=XP
  YPOLD=YP
  ZPOLD=ZP
  J=0
  GO TO 180
802  IBACK=1
  IF (K.EQ.1) GO TO 801
  XB = FPS
  DEN = (XB-XPOLD)/(XP-XPOLD)
  YB = YPOLD+(YP-YPOLD)*DEN
  ZB = ZPOLD+(ZP-ZPOLD)*DEN
  A = D/XB
  XPOLD=XP
  YPOLD=YP
  ZPOLD=ZP
  YP=YB
  ZP=ZB
  GO TO 852
810  IF (IBACK.EQ.0) GO TO 850
  IBACK=0
  XB = EPS
  DEN = (XB-XPOLD)/(XP-XPOLD)
  YB = YPOLD+(YP-YPOLD)*DEN
  ZB = ZPOLD+(ZP-ZPOLD)*DEN
  A = D/XB
  L=1
  XB = -A*YB
  YB = A*ZB
  XA = (XB*CT+YB*ST)*XFLIP
  YA = (YB*CT-XB*ST)*YFLIP
  IF ((ABS(XA).GT.XM).OR.(ABS(YA).GT.YM)) GOTO 850
  L = 0
  XU(2) = X0(1)

```

```

DO 16101 M=1,J*
XO(M)=XO(M)+XM
16101 YO(M)=YO(M)+YM
CALL LINE (XO,YO,J,1)
16109 IF(JLINE.EQ.0) GO TO 16110
J=0
GO TO 180
16110 CONTINUE
XO(1)=XXX
YO(1)=YYY
XS(1)=XS(J)
YS(1)=YS(J)
J = 1
180 CONTINUE
RETURN
10101 IDEN(IERR) = IDEN(IERR)+1
IF(IDEN(IERR).GT.20) GO TO 10104
PRINT 10102,IDEN(IERR),IERR,DEN,FRNO,K
10102 FORMAT (1X,I10,'. DIVIDE ERROR',I3,E10.2,5X,'FRAME',F6.0,'. POINT'
1,I4)
10104 DEN = SIGN(EPS,DEN)
GO TO (10105,10303,10304,123,143,14401),IERR
10105 STOP
C
ENTRY OBAXIS(/XOB/,/YOB/,/ZOB/,/PHI/,/THETA/,/PSI/)
XOR = XOB
YOR = YOB
ZOR = ZOB
A=PHI
IF (IANGLE.NE.0) A = A*CON
SPH = SIN(A)
CPH = COS(A)
A=THETA
IF (IANGLE.NE.0) A = A*CON
STH = SIN(A)
CTH = COS(A)
A=PSI
IF (IANGLE.NE.0) A = A*CON
SPS = SIN(A)
CPS = COS(A)
IF (JEULER.NE.0) GO TO 200
XX = CTH*CPS
A = STH*CPS
YX = A*SPH-CPH*SPS
ZX = A*CPH+SPH*SPS
XY = CTH*SPS
A = SPS*STH
YY = A*SPH+CPS*CPH
ZY = A*CPH-SPH*CPS
XZ = -STH
YZ = SPH*CTH
ZZ = CPH*CTH
GO TO 201
200 CONTINUE
ZZ = CTH
YZ = CPS*STH
XZ = SPS*STH
ZY = -STH*CPH
ZX = STH*SPH
XX = CPS*CPH-SPS*CTH*SPH
YX = -SPS*CPH-CPS*CTH*SPH

```

```

      IF (L.NE.0) GO TO 104
C      OLD POINT IN, NEW (X IN, Y OUT)
      L = 1
      XA = XO(J)
      YA = YO(J)
      YO(J) = SIGN(YM,YA)
      DEN = YA-YO(J-1)
      IF (ABS(DEN).GE.EPS) GO TO 123
      IERR = 4
      GO TO 10101
123  DY = (YO(J)-YO(J-1))/DEN
      XO(J) = XO(J-1)+DY*(XA-XO(J-1))
      GO TO 10301
140  IF (L.EQ.0) GO TO 160
C      NEW POINT IN, OLD PT. OUT.
142  L = 0
      XO(2) = XO(1)
      YO(2) = YO(1)
      XS(2)=XO(2)
      YS(2)=YO(2)
      XS(1)=XA
      YS(1)=YA
      IF (ABS(XA).LE.XM) GO TO 144
C      NEW POINT IN, OLD (X OUT)
      XO(1) = SIGN(XM,XA)
      DEN = XO(2)-XA
      IF (ABS(DEN).GE.EPS) GO TO 143
      IERR = 5
      GO TO 10101
143  DX = (XO(1)-XA)/DEN
      YO(1) = YA+DX*(YO(2)-YA)
      IF (ABS(YO(1)).LE.YM) GO TO 145
C      NEW POINT IN, OLD (Y OUT)
144  YO(1) = SIGN(YM,YA)
      DEN = YO(2)-YA
      IF (ABS(DEN).GE.EPS) GO TO 14401
      IERR = 6
      GO TO 10101
14401 DY = (YO(1)-YA)/DEN
      XO(1) = XA+DY*(XO(2)-XA)
145  J=2
      GO TO 16001
160  IF (J.GE.20) GO TO 161
16001 IF (K.LT.N) GO TO 180
      IF (J.LE.0) RETURN
161  XXX=XO(J)
      YYY = YO(J)
      JLINE=0
16102 DO 16103 M=1,J
      IF((ABS(XO(M)).GT.XM).OR.(ABS(YO(M)).GT.YM)) GO TO 16104
16103 CONTINUE
      GO TO 16108
16104 PRINT 16105,K,N,L,IBACK,FRNO,(M,XS(M),YS(M),XO(M),YO(M),M=1,J)
16105 FORMAT('OEDGE ERROR. K,N,L,IBACK,FRNO =',4I6,F10.0/'(10X,I3,'.',
1 4F20.5))
      FREDGE =0.01*FLOAT(IFRAME)
16106 DO 16107 M=1,J
      IF(ABS(XO(M)).GT.XM) XO(M)=SIGN(XM+FREDGE,XO(M))
      IF(ABS(YO(M)).GT.YM) YO(M)=SIGN(YM+FREDGE,YO(M))
16107 CONTINUE
16108 CONTINUE

```

```

      YO(2) = YO(1)
      XO(1) = XA
      YO(1) = YA
      J=2
850  A =D/XP
851  XPOLD=XP
      YPOLD = YP
      ZPOLD=ZP
852  XP =-A*YP
      YP = A*ZP
      XO(J) =(XP*CT+YP*ST)*XFLIP
      YO(J) =(YP*CT-XP*ST)*YFLIP
      XS(J)= XO(J)
      YS(J)= YO(J)
      IF(NSETS.LT.0) GO TO 90401
      PRINT 904,DX,DY,DZ,DEN,A,XP,YP,  XO(J),YO(J)
904  FORMAT(1X,10E12.4)
90401 CONTINUE
      IF(ABS(XO(J)).LE.XM) GO TO 120
      102 IF (K.NE.1) GO TO 103
10202 L = 1
      XA = XO(1)
      YA = YO(1)
      J=0
      GO TO 180
      103 IF (L.NE.0) GO TO 104
C      OLD POINT IN, NEW(X OUT)
      L = 1
      XA = XO(J)
      YA = YO(J)
      XO(J) = SIGN(XM,XA)
      DEN = XA-XO(J-1)
      IF (ABS(DEN).GE.EPS) GO TO 10303
      IERR = 2
      GO TO 10101
10303 DX = (XO(J)-XO(J-1))/DEN
      YO(J) = YO(J-1)+DX*(YA-YO(J-1))
      IF(ABS(YO(J)).LE.YM) GO TO 10301
C      OLD POINT IN, NEW(X OUT, Y OUT)
      A = YO(J)
      YO(J) = SIGN(YM,A)
      DEN = A-YO(J-1)
      IF (ABS(DEN).GE.EPS) GO TO 10304
      IERR = 3
      GO TO 10101
10304 DY = (YO(J)-YO(J-1))/DEN
      XO(J) = XO(J-1)+DY*(XA-XO(J-1))
10301 JLINE=1
      GO TO 16102
C      BOTH OLD AND NEW POINTS OUT OF RANGE
104  XB = XO(1)
      YB = YO(1)
      DENX = XB-XA
      DENY = YB-YA
      J = IEDGE(0)
      XA=XB
      YA=YB
      IF(J.EQ.0) GO TO 180
      GO TO 10301
      120 IF (ABS(YO(J)).LE.YM) GO TO 140
      122 IF (K.EQ.1) GO TO 10202

```



```

      XY = SPS*CTH*CPH+CPS*SPH
      YY =-SPS*SPH+CPS*CTH*CPH
201  CONTINUE
      IF (NSETS.LT.0) RETURN
      NSFTS= NSETS-1
      PRINT 910,XOR,YOR,ZOR,XX,XY,XZ,YX,YY,YZ,ZX,ZY,ZZ
910  FORMAT ('00BAXIS',6E12.3/(7X,6E12.3))
      RETURN
      END
C$$$  SUBROUTINES XF, YF
C      THIS FORTRAN DECK ORIGINALLY PRODUCED AS PART OF
C      THE SINGLE VEHICLE ACCIDENT MOVIE PROGRAM (PART A)
C
C      DEVELOPED BY  CALVIN M. THEISS
C                      TRANSPORTATION RESEARCH DEPT.
C                      CORNELL AERONAUTICAL LABORATORY
C                      BUFFALO, NEW YORK  14221
C
      SUBROUTINE YF(/N/)
      COMMON /COMEDG/ XO(20),YO(20),XA,XB,DENX,DENY,YA,YB
1  J = N
      IF (ABS(DENX).LT.(0.01)) GO TO 2
      YO(J) = YA + (XO(J) - XA)*DENY/DENX
      RETURN
2  YO(J) = YA
      RETURN
      ENTRY XF(/M/)
      J = M
      IF (ABS(DENY).LT.(0.01)) GO TO 3
      XU(J) = XA+(YO(J)-YA)*DENX/DENY
      RETURN
3  XO(J) = XA
      RETURN
      END
C$$$  SUBROUTINE CAMSET
C      THIS FORTRAN DECK ORIGINALLY PRODUCED AS PART OF
C      THE SINGLE VEHICLE ACCIDENT MOVIE PROGRAM (PART A)
C
C      DEVELOPED BY  CALVIN M. THEISS
C                      TRANSPORTATION RESEARCH DEPT.
C                      CORNELL AERONAUTICAL LABORATORY
C                      BUFFALO, NEW YORK  14221
C                      (RELEASE DATE,  OCT. 14,1968)
C
      SUBROUTINE CAMSET(POS,/ITYPE/,/INVT/)
      COMMON/COMFRM/FRNG,XFR(5),YFR(5),XM,YM,USED,SECT,CON,D,FXP,FYP,
1  FZP,CA,CE,SA,SE,CACE,SASE,SACE,CASE,CT,ST,IANGLE,JEULER
      COMMON /COMSET/NSETS,XFLIP,YFLIP,FNL,FPS
      DIMENSION POS(7),DS(3),CAM(7)
      EQUIVALENCE (DX,DS(1)),(DY,DS(2)),(DZ,DS(3))
      EQUIVALENCE (CAM(1),XA,XB),(CAM(2),YA,YB),(CAM(3),ZA,ZB),
1  (CAM(4),XF,AZ,XC),(CAM(5),YF,FL,YC),(CAM(6),ZF,FLB,ZC),
2  (CAM(7),TIA,TIB)
C
100  DO 101 J=1,7
101  CAM(J) = POS(J)
      ITYPES = ITYPE
      IF (ITYPES.LE.2) GO TO 1
      NSETS = ITYPES/2
      IF ((NSETS*2-ITYPES).EQ.0) GO TO 103
      ITYPES =1

```

```

      GO TO 104
103  ITYPES=2
      NSETS = NSETS-1
104  ITYPE = ITYPES
      C
      1  GO TO (3,10),ITYPES
      PRINT 2
      2  FORMAT ('OILLEGAL CAMERA TYPE.')
      STOP
      3  DO 4 J=1,3
      4  DS(J) =CAM(J+3)-CAM(J)
      A = DX**2+DY**2
      IF (A.NE.0.0) GO TO 412
      IF (DZ.NE.0.0) GO TO 411
      PRINT 410
410  FORMAT ('OZERO FOCAL LENGTH UNACCEPTABLE.')
      STOP
411  D=ABS(DZ)
      SA=0.0
      CE=0.0
      CA=1.0
      SF =SIGN(1.0,DZ)
      CASE=SE
      CACE=0.0
      SACE=0.0
      SASE=0.0
      GO TO 413
412  D = SQRT(A+DZ**2)
      A = SQRT(A)
      SE = DZ/D
      CE = A/D
      CA=DX/A
      SA =DY/A
      CACE=DX/D
      SACE=DY/D
401  CONTINUE
      CASE=CA*SE
      SASE=SA*SE
413  FXP = XB*CACE +YB*SACE+ZB*SE+D
      FYP = YB*CA-XB*SA
      FZP = ZB*CE-YB*SASE-XB*CASF
      D = D*ENL
      A = CAM(7)*CON
      GO TO (402,405,404,406),INVT
      GO TO 408
402  XFLIP = 1.0
403  YFLIP = 1.0
      GO TO 408
404  XFLIP = -1.0
      GO TO 403
405  XFLIP = 1.0
      GO TO 407
406  XFLIP = -1.0
407  YFLIP = -1.0
408  CONTINUE
      5  ST = SIN(A)
      CT = COS(A)
      IF(NSETS)903,902,904
902  NSETS=-2
903  RETURN
904  PRINT 900,D,FXP,FYP,FZP,CA,CE,SA,SE,CACE,SASE,SACE,CACE,CT,ST

```

```

900  FORMAT ('0CAMSFT ',8E12.4/(17X,8E12.4))
      RETURN
C
10   D =CAM(6)
      A = CAM(5)*CON
      SE = SIN(A)
      CE=COS(A)
      A=CAM(4)*CON
      CA= COS(A)
      SA = SIN(A)
      CACE = CA*CF
      SACE =SA*CE
      GO TO 401
      END
C$$$  BLOCK DATA   SVA MOVIE  PART C   HARVEY SELIB'S COMMON
      BLOCK DATA
      COMMON /SPZPLT/  INT,MODE,XS,YS
      DATA  MODE/-1./, INT/63/, XS/10.0/, YS/10.0/
      END

```

Appendix V

BICYCLE GRAPHICS INPUT DATA LISTING

**** SCHWINN BICYCLE COMPUTER GRAPHICS

01

10.0	10.0	0.	2.	2.0	.14	.05	0	110110002	0	1	0	1	0	00300.28
0	4	4	1920.	-300.	-70.	0.0	-40.	2.30	0.	0.	0.	0.	0.	
	.5056	13.5	0.	0.	0.	0.	0.	0.	0.	0.	0.	0.	0.	
-26.	0.		-8.		.5078		-26.	-4.8		-11.5		-26.		
2.5	-11.5		4.5		6.		-2.7	0.		-6.		5.7		
0.	0.		-23.8		0.		0.	3.5		-23.8		0.		
-5.0	-23.8		.4		11.6		-30.8	.4		-11.6		-30.8		
16.	18.		12.		12.		.5078	-16.5		-1.5		14.5		
5.798	0.		13.7245											

CHASIS	4	65	0											
-34.0000		-0.5000	13.0000		11.5000	90.000	0.0	0.0						
RRWHEEL2	4	65	0											
-34.0000		0.5000	13.0000		11.5000	90.000	0.0	0.0						
RRWHEEL3	4	65	0											
-34.0000		-0.5000	13.0000		13.5000	90.000	0.0	0.0						
RRWHEEL4	4	65	0											
-34.0000		0.5000	13.0000		13.5000	90.000	0.0	0.0						
RRWHEEL5	4	65	0											
-34.0000		-1.0000	13.0000		12.0000	90.000	0.0	0.0						
RRWHEEL6	4	65	0											
-34.0000		1.0000	13.0000		12.0000	90.000	0.0	0.0						
RRWHEEL7	4	65	0											
-34.0000		-1.0000	13.0000		13.0000	90.000	0.0	0.0						
RRWHEEL8	4	65	0											
-34.0000		1.0000	13.0000		13.0000	90.000	0.0	0.0						
RRHUB1	4	17	0											
-34.0000		-1.5000	13.0000		1.5000	90.000	0.0	0.0						
RRHUB2	4	17	0											
-34.0000		1.5000	13.0000		1.5000	90.000	0.0	0.0						
CRANK	4	20	0											
-16.5000		-1.5000	14.5000		3.0000	90.000	0.0	0.0						
CHAIN1	2	2	0											
-16.5000		-1.5000	11.5000		-34.0000	-1.5000		11.5000						
CHAIN2	2	2	0											
-16.5000		-1.5000	17.5000		-34.0000	-1.5000		14.5000						
LOFRAM1	2	5	0											
-19.5000		-1.5000	14.2000		-33.5000	-1.5000		12.7000						
-26.5000		-1.5000	2.0000		-23.0000	-0.5000		-3.5000						
-17.5000		-0.5000	11.5000		-13.0000	0.0		8.0000						
LOFRAM2	2	5	0											
-19.5000		1.5000	14.2000		-33.5000	1.5000		12.7000						
-26.5000		1.5000	2.0000		-23.0000	0.5000		-3.5000						
-17.5000		0.5000	11.5000		-13.0000	0.0		8.0000						
RRFRAM1	2	4	0											
-19.5000		-1.5000	14.8000		-33.5000	-1.5000		13.3000						
-33.5000		1.5000	13.3000		-19.5000	1.5000		14.8000						
RRFRAME2	2	8	0											
-24.0000		-0.5000	-6.0000		-23.3000	-0.5000		-4.2000						
-27.0000		-1.5000	1.5000		-34.0000	-1.5000		12.5000						
-34.0000		1.5000	12.5000		-27.0000	1.5000		1.5000						
-23.3000		0.5000	-4.2000		-24.0000	0.5000		-6.0000						
LUFAME	2	3	0											
-23.2000		-0.5000	-6.2000		-22.5000	-0.5000		-4.5000						
-5.0000		-0.5000	-4.5000		-13.0000	0.0		8.0000						
RUFAME	2	3	0											
-23.2000		0.5000	-6.2000		-22.5000	0.5000		-4.5000						
-5.0000		0.5000	-4.5000		-13.0000	0.0		8.0000						
LCFRAME1	2	3	0											

	-16.5000	-0.5000	11.5000	-22.0000	-0.5000	-3.5000
	-4.5000	-0.5000	-3.5000	-13.0000	0.0	8.0000
RCFRAME1	2	3	0			
	-16.5000	0.5000	11.5000	-22.0000	0.5000	-3.5000
	-4.5000	0.5000	-3.5000	-13.0000	0.0	8.0000
LCFRAME2	2	2	0			
	-3.3000	-0.5000	-1.7000	-15.0000	-0.5000	12.0000
RCFRAME2	2	2	0			
	-3.3000	0.5000	-1.7000	-15.0000	0.5000	12.0000
LCFRAME3	2	2	0			
	-14.3000	-0.5000	12.5000	-2.8000	-0.5000	-0.8000
RCFRAME3	2	2	0			
	-2.8000	0.5000	-0.8000	-14.3000	0.5000	12.5000
SEAT	2	16	0			
	-19.0000	-1.0000	-8.0000	-26.5000	-3.0000	-8.0000
	-26.5000	3.0000	-8.0000	-19.0000	1.0000	-8.0000
	-19.0000	-1.0000	-8.0000	-19.0000	-1.0000	-7.0000
	-26.0000	-3.0000	-5.5000	-26.5000	-3.0000	-8.0000
	-26.0000	-3.0000	-5.5000	-26.0000	3.0000	-5.5000
	-26.5000	3.0000	-8.0000	-26.0000	3.0000	-5.5000
	-19.0000	1.0000	-7.0000	-19.0000	1.0000	-8.0000
	-19.0000	1.0000	-7.0000	-19.0000	-1.0000	-7.0000
FORKTUBE	2	12	0			
	-2.4000	-0.6000	-0.2000	-6.0000	-0.6000	-6.0000
	-4.9000	-0.6000	-6.5000	-1.4000	-0.6000	-0.7000
	-1.4000	0.6000	-0.7000	-5.0000	0.6000	-6.5000
	-5.0000	-0.6000	-6.5000	-5.0000	0.6000	-6.5000
	-6.0000	0.6000	-6.0000	-6.0000	-0.6000	-6.0000
	-6.0000	0.6000	-6.0000	-2.4000	0.6000	-0.2000
		1				
FTFORK	4	65				
	1.202	-0.50	-.7245	11.50	90.00	0.0
		65				
	1.202	.50	-.7245	11.50	90.00	0.0
		65				
	1.202	-0.50	-.7245	13.50	90.00	0.0
		65				
	1.202	.50	-.7245	13.50	90.00	0.0
		65				
	1.202	-1.00	-.7245	12.00	90.00	0.0
		65				
	1.202	1.00	-.7245	12.00	90.00	0.0
		65				
	1.202	-1.00	-.7245	13.00	90.00	0.0
		65				
	1.202	1.00	-.7245	13.00	90.00	0.0
FTHUB1	4	17				
	1.202	-0.50	-.7245	1.	90.00	0.0
FTHUB2	4	17				
	1.202	0.50	-.7245	1.	90.00	0.0
		2				
		60				
	2.5	-0.5	-24.8	2.5	-4.1	-24.8
	4.9	-6.7	-26.6	4.2	-9.0	-28.6
	0.1	-10.8	-31.0	0.4	-11.6	-30.8
	0.0	-11.6	-30.0	-0.3	-10.8	-30.2
	0.1	-10.8	-31.0	0.4	-11.6	-30.8
	4.9	-9.6	-28.2	4.7	-6.5	-26.1
	3.3	-3.7	-24.4	3.3	3.7	-24.4
	4.7	6.5	-26.1	4.9	9.6	-28.2
	0.4	11.6	-30.8	0.1	10.8	-31.0
	-0.3	10.8	-30.2	4.1	8.8	-27.7

4.7	6.8	-25.9	2.1	3.9	-24.1
2.1	0.5	-24.1	2.5	0.5	-24.8
2.5	4.1	-24.8	4.9	6.7	-26.6
4.2	9.0	-28.6	0.1	10.8	-31.0
-0.3	10.8	-30.2	0.0	11.6	-30.0
0.4	11.6	-30.8	0.0	11.6	-30.0
4.8	9.5	-27.3	5.6	6.5	-25.4
2.9	3.6	-23.7	2.9	-3.6	-23.7
5.6	-6.5	-25.4	4.8	-9.5	-27.3
0.0	-11.6	-30.0	-0.3	-10.8	-30.2
4.1	-8.8	-27.7	4.7	-6.8	-25.9
2.1	-3.9	-24.1	2.1	-0.5	-24.1
2.5	-0.5	-24.8	0.5	-0.5	-26.0
-0.5	-0.5	-26.0	-0.5	-0.5	-22.5
0.5	-0.5	-22.5	0.5	-0.5	-25.0
2.1	-0.5	-24.1	2.1	0.5	-24.1
0.5	0.5	-25.0	0.5	0.5	-22.5
-0.5	0.5	-22.5	-0.5	0.5	-26.0
-0.5	-0.5	-26.0	-0.5	0.5	-26.0
0.5	0.5	-26.0	2.5	0.5	-24.8

	2	26			
0.7	-1.5	-15.5	+0.5	-1.5	-3.0
2.0	-1.5	-0.5	1.3	-1.5	0.0
-0.5	-1.5	-3.0	-0.7	-1.5	-15.5
0.7	-1.5	-15.5	0.7	1.5	-15.5
-0.7	1.5	-15.5	-0.7	-1.5	-15.5
-0.7	-1.5	-16.5	0.7	-1.5	-16.5
0.7	-1.5	-15.5	0.7	-1.5	-16.5
0.7	1.5	-16.5	0.7	1.5	-15.5
0.7	1.5	-16.5	-0.7	1.5	-16.5
-0.7	-1.5	-16.5	-0.7	1.5	-16.5
-0.7	1.5	-15.5	-0.5	1.5	-3.0
1.3	1.5	0.0	2.0	1.5	-0.5
0.5	1.5	-3.0	0.7	1.5	-15.5

	1					
PEDALS	4	17				
	1.5	0.	0.	.75	90.00	0.0
	4	17				
	-1.5	0.	0.	.75	90.00	0.0
	4	17				
	0.	0.	-1.5	.75	90.00	0.0
	4	17				
	0.	0.	1.5	.75	90.00	0.0
	2	14				
	-.5	0.	-.5	.5	0.	-.5
	.5	-.5	-.5	6.	-1.	-.25
	6.	-1.25	-.25	-.5	-.75	-.5
	-.5	0.	-.5	-.5	0.	.5
	-.5	-.75	.5	6.	-1.25	.25
	6.	-1.	.25	.5	-.5	.5
	.5	0.	.5	-.5	0.	.5
	2	2				
	.5	0.	-.5	.5	0.	.5
	2	2				
	-.5	-.75	-.5	-.5	-.75	.5
	2	2				
	.5	-.5	-.5	.5	-.5	.5
	2	2				
	6.	-1.25	-.25	6.	-1.25	.25
	2	2				
	6.	-1.	-.25	6.	-1.	.25

		2	14				
			2.	-.5	.5	2.	-.5
			3.75	-.5	-6.	4.25	-.25
			4.	-.25	-.5	3.5	-.5
			2.	-.5	-.5	2.	.5
			3.5	.5	-6.	4.	.25
			4.25	.25	.5	3.75	.5
			2.	.5	-.5	2.	.5
		2	2				
			2.	.5	.5	2.	-.5
		2	2				
			3.75	.5	.5	3.75	-.5
		2	2				
			3.5	.5	-.5	3.5	-.5
		2	2				
			4.	.25	-6.	4.	-.25
		2	2				
			4.25	.25	-6.	4.25	-.25
		1					
TORSO		2	34				
3.5	1.		-25.4	2.5	1.2		-25.5
.6	2.4		-26.5	.4	2.5		-27.6
.1	3.		-27.5	-.95	3.2		-28.75
-.7	3.4		-29.8	-.7	3.0		-29.8
.5	2.9		-29.5	.7	2.8		-28.7
1.3	2.8		-28.7	1.9	2.6		-30.0
1.75	2.8		-31.5	2.4	2.2		-32.3
3.6	1.6		-31.8	3.6	-1.6		-31.8
2.4	-2.2		-32.3	1.75	-2.8		-31.5
1.9	-2.6		-30.0	1.3	-2.8		-28.7
.7	-2.8		-28.7	.5	-2.9		-29.5
-.7	-3.0		-29.8	-.7	-3.4		-29.8
-.95	-3.2		-28.75	.1	-3.		-27.5
.4	-2.5		-27.6	.6	-2.4		-26.5
2.5	-1.2		-25.5	3.5	-1.		-25.4
3.5	1.		-25.4	3.85	.8		-25.9
3.85	-.8		-25.9	3.5	-1.		-25.4
		2	15				
-2.	2.		-27.	-3.	2.35		-30.7
-2.5	2.4		-32.75	-1.5	2.4		-33.6
.5	2.4		-34.	3.	2.1		-33.5
3.9	1.6		-32.8	3.9	-1.6		-32.8
3.	-2.1		-33.5	.5	-2.4		-34.
-1.5	-2.4		-33.6	-2.5	-2.4		-32.75
-3.	-2.35		-30.7	-2.	-2.		-27.
-2.	2.		-27.				
		2	5				
3.5	2.		-29.5	3.5	1.35		-29.75
3.5	.35		-29.5	3.5	1.35		-29.4
3.5	2.		-29.5				
		2	5				
3.5	-2.		-29.5	3.5	-1.35		-29.75
3.5	-.35		-29.5	3.5	-1.35		-29.4
3.5	-2.		-29.5				
		2	10				
3.5	2.		-30.	3.75	1.65		-30.2
4.1	.9		-30.3	3.8	.25		-29.8
4.6	.5		-28.	4.6	-.5		-28.
3.8	-.25		-29.8	4.1	-.9		-30.3
3.75	-1.65		-30.2	3.5	-2.		-30.
		2	8				

3.8	1.2	-27.	4.1	.4	-27.25
4.1	-.4	-27.25	3.8	-1.2	-27.
4.	-.8	-26.8	4.	.8	-26.8
3.8	1.2	-27.	3.8	-1.2	-27.
4.15	0.	2	3.9	0.	-27.25
	2	19			
3.3	.5	0.	3.3	3.5	-7.
3.3	5.2	-7.	0.	5.2	-7.
0.	4.75	-10.	0.	4.9	-11.8
2.	3.6	-12.	3.5	2.5	-15.
3.6	1.	-15.7	3.6	-1.	-15.7
3.5	-2.5	-15.	2.	-3.6	-12.
0.	-4.9	-11.8	0.	-4.75	-10.
0.	-5.2	-7.	3.3	-5.2	-7.
3.3	-3.5	-7.	3.3	-.5	0.
3.3	.5	0.			
0.	2	11			
3.75	6.	-23.8	1.	6.	-23.8
3.7	5.5	-19.5	3.7	4.5	-18.6
3.7	.5	-18.6	3.7	0.	-19.35
3.7	-.5	-18.6	3.7	-4.5	-18.6
3.75	-5.5	-19.5	1.	-6.	-23.8
0.	-6.	-23.8			
0.	2	5			
0.	6.	-23.8	0.	5.5	-19.5
0.	4.9	-11.8	0.	4.75	-10.
0.	5.25	-7.			
0.	2	5			
0.	-6.	-23.8	0.	-5.5	-19.5
0.	-4.9	-11.8	0.	-4.75	-10.
0.	-5.25	-7.			
3.3	2	10			
-4.3	4.	0.	-2.75	4.	0.
-3.25	4.	-2.25	-4.5	4.	-5.
-4.25	4.	-8.	-3.	4.	-10.5
-2.3	4.	-15.6	-4.25	4.	-21.6
	4.	-23.6	0.	4.	-24.3
3.3	2	10			
-4.3	-4.	0.	-2.75	-4.	0.
-3.25	-4.	-2.25	-4.5	-4.	-5.
-4.25	-4.	-8.	-3.	-4.	-10.5
-2.3	-4.	-15.5	-4.25	-4.	-21.6
	-4.	-23.6	0.	-4.	-24.3
3.3	2	10			
-4.3	0.	0.	-2.75	0.	0.
-3.25	0.	-2.25	-4.5	0.	-5.
-4.25	0.	-8.	-3.	0.	-10.5
-2.85	0.	-15.6	-4.25	0.	-21.6
	0.	-24.8	-2.	0.	-27.
1.	2	6			
1.3	6.	-23.8	1.3	.3	-23.35
1.3	.3	-23.	1.3	-.3	-23.
	-3.	-23.35	1.	-6.	-23.8
0.	2	3			
0.	6.	-23.8	0.	2.25	-25.
0.	.5	-23.5			
0.	2	3			
0.	-6.	-23.8	0.	-2.25	-25.
0.	-.5	-23.5			
	2	3			

1.	0.	-23.	1.5	0.	-25.
2.5	0.	-25.5			
	1				
RFARM	2	7			
0.	0.	0.	0.	-1.	-1.6
3.	-1.5	-1.5	10.	-.5	-.8
12.5	-1.2	-1.75	12.5	-.3	-1.75
11.6	0.	-1.2			
	2	8			
12.5	-1.2	-1.75	13.6	0.	-.75
12.8	1.5	-1.	11.5	1.1	-1.15
10.	.6	-.8	2.	1.8	-1.5
0.	1.25	-1.6	0.	0.	0.
	2	13			
0.	0.	0.	-.9	-1.	1.6
3.	-1.5	1.6	5.	-1.2	1.6
10.	-.5	1.	11.5	-.8	1.6
12.6	0.	1.45	11.5	1.1	1.6
10.	.6	1.	5.	1.3	1.6
2.	1.8	1.6	-.9	1.2	1.6
0.	0.	0.			
	2	6			
11.85	-.2	-1.2	12.3	-.5	-1.
12.8	0.	-.9	12.3	.5	-1.
11.85	.2	-1.2	11.85	-.2	-1.2
	2	2			
13.6	0.	-.75	12.6	0.	1.45
	2	3			
12.3	-.5	-1.	12.5	-1.2	-1.75
12.5	-1.2	1.6			
	1				
LFARM	2	14			
0.	0.	0.	0.	-1.3	-1.8
2.	-1.8	-1.6	10.	-.65	-.9
12.9	-1.5	-.8	13.65	0.	-.75
12.5	1.2	-1.	12.3	.5	-1.1
12.8	0.	-1.	12.3	-.5	-1.1
11.8	-.2	-1.2	11.8	.2	-1.2
12.3	.5	-1.1	12.5	1.2	-1.0
	2	7			
11.65	0.	-1.3	12.5	.35	-1.75
12.5	1.1	-1.75	10.	.5	-.9
3.	1.4	-1.5	0.	1.	-1.8
0.	0.	0.			
	2	13			
0.	0.	0.	-1.	-1.	1.6
3.	-1.5	1.6	5.	-1.2	1.6
10.	-.6	1.	11.5	-.8	1.6
12.7	0.	1.4	11.5	1.1	1.6
10.	.65	1.	5.	1.4	1.6
2.	1.8	1.6	-1.	1.2	1.6
0.	0.	0.			
	2	2			
12.7	0.	1.4	13.65	0.	-.75
	1				
LUARM	2	8			
0.	1.3	-.8	.8	1.75	-1.75
3.6	1.75	-1.75	6.	1.5	0.
3.6	1.75	1.75	.8	1.75	1.75
0.	1.3	.8	0.	1.3	-.8
	2	5			

3.6	1.75	-1.75	12.2	1.5	-1.75
12.	0.	0.	12.	-1.	-1.75
4.-	-1.	-1.75			
	2	7			
3.6	1.75	1.75	12.2	1.5	1.75
13.6	0.	1.75	12.	0.	0.
13.6	0.	1.75	12.	-1.	1.75
4.	-1.	1.75			
	1				
RUARM	2	8			
0.	-1.3	-.8	.8	-1.75	-1.75
3.6	-1.75	-1.75	6.	-1.5	0.
3.6	-1.75	1.75	.8	-1.75	1.75
0.	-1.3	.8	0.	-1.3	-.8
	2	5			
3.6	-1.75	-1.75	12.2	-1.5	-1.75
12.	0.	0.	12.	1.	-1.75
4.	1.	-1.75			
	2	7			
3.6	-1.75	1.75	12.2	-1.5	1.75
13.6	0.	1.75	12.	0.	0.
13.6	0.	1.75	12.	1.	1.75
4.	1.	1.75			
	1				
RTHIGH	2	9			
0.	-1.25	-3.6	9.6	-.5	-3.
15.	-.25	-2.	17.25	0.	-2.3
17.5	-.6	-2.3	18.3	-.4	-1.5
18.	1.	-1.5	17.2	.75	-2.3
17.25	0.	-2.3			
	2	4			
18.3	-.4	-1.5	17.6	-.25	0.
17.45	.5	0.	18.	1.	-1.5
	2	3			
3.25	-1.	2.7	10.25	-.5	2.7
15.	-.25	2.			
	2	2			
4.	0.	-3.8	15.2	0.	-2.
	2	4			
3.2	0.	1.7	11.	0.	2.
14.	0.	1.7	14.8	0.	1.9
	1				
LTHIGH	2	9			
0.	1.25	-3.6	9.6	.5	-3.
15.	.25	-2.	17.25	0.	-2.3
17.5	.6	-2.3	18.3	.4	-1.5
18.	-1.	-1.5	17.2	-.75	-2.3
17.25	0.	-2.3			
	2	4			
18.3	.4	-1.5	17.6	.25	0.
17.45	-.5	0.	18.	-1.	-1.5
	2	3			
3.25	1.	2.7	10.25	-.5	2.7
15.	.25	2.			
	2	2			
4.	0.	3.8	15.2	0.	2.
	2	4			
3.2	0.	-1.7	11.	0.	-2.
14.	0.	-1.7	14.8	0.	-1.9
	1				
RCALF	2	2			

- .3	0.	-1.6	14.8	0.	- .5
	2	3			
1.25	0.	2.25	6.	0.	3.
14.5	0.	1.			
	2	3			
0.	2.	1.1	6.	2.2	1.
14.5	.6	.6			
	2	5			
.1	-1.9	1.2	1.25	-1.8	1.1
3.25	-1.5	1.	6.2	-1.9	.9
14.5	-.5	.7			
	1				
LCALF	2	2			
- .3	0.	-1.6	14.8	0.	- .5
	2	3			
1.25	0.	2.25	6.	0.	3.
14.5	0.	1.			
	2	3			
0.	-2.	1.1	6.	-2.2	1.
14.6	-.5	.7			
	2	5			
.1	1.9	1.2	1.25	1.8	1.1
3.25	1.5	1.	6.2	1.9	.9
14.5	.5	.7			
	1				
RFOOT	2	7			
-6.5	-.75	0.	-1.3	-1.7	0.
2.	-1.7	0.	2.	1.7	0.
-1.3	1.7	0.	-6.5	.75	0.
-6.5	-.75	0.			
	2	4			
2.	-1.7	0.	2.3	-1.5	- .5
2.3	1.5	-.5	2.	1.7	0.
	2	4			
-6.5	-.75	0.	-4.5	0.	-4.
-1.3	.75	-1.3	2.3	1.5	- .5
	2	4			
-6.5	.75	0.	-4.5	0.	-4.
-1.3	-.75	-1.3	2.3	-1.5	- .5
	1				
LFOOT	2	7			
-6.5	-.75	0.	-1.3	-1.7	0.
2.	-1.7	0.	2.	1.7	0.
-1.3	1.7	0.	-6.5	.75	0.
-6.5	-.75	0.			
	2	4			
2.	-1.7	0.	2.3	-1.5	- .5
2.3	1.5	-.5	2.	1.7	0.
	2	4			
-6.5	-.75	0.	-4.5	0.	-4.
-1.3	.75	-1.3	2.3	1.5	- .5
	2	4			
-6.5	.75	0.	-4.5	0.	-4.
-1.3	-.75	-1.3	2.3	-1.5	- .5
	1				
CONE	2	5			
4.	4.	0.	4.	-4.	0.
-4.	-4.	0.	-4.	4.	0.
4.	4.	0.			
	2	5			
4.	4.	-.75	4.	-4.	-.75

-4.	-4.	-.75	-4.	4.	-.75
4.	4.	-.75			
	4	16			
0.	0.	-.75	3.	0.	90. 0.
	4	16			
0.	0.	-10.75	1.25	0.	90. 0.
	2	2			
0.	-3.	-.75	0.	-1.25	-10.75
	2	2			
1.	-2.8	-.75	.5	-1.175	-10.75
	2	2			
2.175	-2.175	-.75	.9	-.9	-10.75
	2	2			
2.8	-1.	-.75	1.175	-.5	-10.75
	2	2			
3.	0.	-.75	1.25	0.	-10.75
	2	2			
2.8	1.	-.75	1.175	.5	-10.75
	2	2			
2.175	2.175	-.75	.9	.9	-10.75
	2	2			
1.	2.8	-.75	.5	1.175	-10.75
	2	2			
0.	3.	-.75	0.	1.25	-10.75
	2	2			
-1.	2.8	-.75	-.5	1.175	-10.75
	2	2			
-2.175	2.175	-.75	.9	.9	-10.75
	2	2			
-2.8	1.	-.75	-1.175	.5	-10.75
	2	2			
-3.	0.	-.75	-1.25	0.	-10.75
	2	2			
-2.8	-1.	-.75	-1.175	-.5	-10.75
	2	2			
-2.175	-2.175	-.75	-.9	-.9	-10.75
	2	2			
-1.	-2.8	-.75	-.5	-1.175	-10.75
	2	2			
4.	4.	0.	4.	4.	-.75
	2	2			
4.	-4.	0.	4.	-4.	-.75
	2	2			
-4.	-4.	0.	-4.	-4.	-.75
	2	2			
-4.	4.	0.	-4.	4.	-.75
	1				
LAYOUT	2	2	1		
-20.	-1000.	0.	-20.	1000.	0.
	2	3	1		
20.	-1000.	0.	20.	-20.	0.
300.	-40.	0.			
	2	4	1		
20.	1000.	0.	20.	20.	0.
100.	15.	0.	100.	1000.	0.
	1				
HOUSE	2	9			
160.	180.	0.	190.	80.	0.
340.	80.	0.	340.	-80.	0.
-340.	-80.	0.	-340.	80.	0.
-160.	80.	0.	-160.	180.	0.

160.	80.	0.			
	2	9			
160.	180.	-100.	160.	80.	-100.
340.	80.	-100.	340.	-80.	-100.
-340.	-80.	-100.	-340.	80.	-100.
-160.	80.	-100.	-160.	180.	-100.
160.	80.	-100.			
	2	3			
-340.	80.	-100.	-220.	0.	-180.
-340.	-80.	-100.			
	2	3			
340.	80.	-100.	220.	0.	-180.
340.	-80.	-100.			
	2	2			
-220.	0.	-180.	220.	0.	-180.
	2	3			
160.	180.	-100.	160.	0.	-180.
160.	80.	-100.			
	2	3			
-160.	180.	-100.	-160.	0.	-180.
-160.	80.	-100.			
	2	2			
-160.	180.	-100.	-160.	180.	0.
	2	2			
160.	180.	-100.	160.	180.	0.
	2	2			
-160.	80.	-100.	-160.	80.	0.
	2	2			
160.	80.	-100.	160.	80.	0.
	2	2			
-340.	80.	-100.	-340.	80.	0.
	2	2			
340.	80.	-100.	340.	80.	0.
	2	2			
-340.	-80.	-100.	-340.	-80.	0.
	2	2			
340.	-80.	-100.	340.	-80.	0.
	2	14			
160.	80.	-80.	340.	80.	-80.
330.	80.	-80.	330.	80.	-60.
190.	80.	-60.	190.	80.	-40.
330.	80.	-40.	330.	80.	-20.
190.	80.	-20.	190.	80.	0.
330.	80.	0.	330.	80.	-80.
190.	80.	-80.	190.	80.	0.
	2	5			
-135.	180.	0.	-135.	180.	-90.
-85.	180.	-90.	-85.	180.	0.
-135.	180.	0.			
	2	5			
-140.	180.	-100.	-80.	180.	-100.
-80.	180.	-90.	-140.	180.	-90.
-140.	180.	-100.			
	2	2			
-90.	180.	-45.	-90.	180.	-35.
	2	5			
-120.	180.	-80.	-100.	180.	-80.
-100.	180.	-60.	-120.	180.	-60.
-120.	180.	-80.			
	2	5			
-60.	180.	-80.	-30.	180.	-80.

-30.	180.	-40.	-60.	180.	-40.
-60.	180.	-80.			
	2	2			
-60.	180.	-60.	-30.	180.	-60.
	2	2			
-45.	180.	-80.	-45.	180.	-40.
	2	5			
-20.	180.	-80.	80.	180.	-80.
80.	180.	-40.	-20.	180.	-40.
-20.	180.	-80.			
	2	5			
90.	180.	-80.	120.	180.	-80.
120.	180.	-40.	90.	180.	-40.
90.	180.	-80.			
	2	2			
90.	180.	-60.	120.	180.	-60.
	2	2			
105.	180.	-80.	105.	180.	-40.
	2	5			
-300.	80.	-80.	-220.	80.	-80.
-220.	80.	-40.	-300.	80.	-40.
-300.	80.	-80.			
	2	4			
-280.	80.	-80.	-280.	80.	-40.
-280.	80.	-60.	-300.	80.	-60.
	2	4			
-240.	80.	-80.	-240.	80.	-40.
-240.	80.	-60.	-220.	80.	-60.
	1				
TERRAIN	2	2			
-5000.	1500.	0.	5000.	1500.	0.
	2	2			
-5000.	1000.	0.	5000.	1000.	0.
	2	2			
-5000.	500.	0.	5000.	500.	0.
	2	2			
-5000.	0.	0.	5000.	0.	0.
	2	2			
-5000.	-500.	0.	5000.	-500.	0.
	2	2			
-5000.	-1000.	0.	5000.	-1000.	0.
	2	2			
-5000.	-1500.	0.	5000.	-1500.	0.
	2	2			
-5000.	1500.	0.	-5000.	-1500.	0.
	2	2			
-4000.	1500.	0.	-4000.	-1500.	0.
	2	2			
-3000.	1500.	0.	-3000.	-1500.	0.
	2	2			
-2000.	1500.	0.	-2000.	-1500.	0.
	2	2			
-1000.	1500.	0.	-1000.	-1500.	0.
	2	2			
0.	1500.	0.	0.	-1500.	0.
	2	2			
1000.	1500.	0.	1000.	-1500.	0.
	2	2			
2000.	1500.	0.	2000.	-1500.	0.
	2	2			
3000.	1500.	0.	3000.	-1500.	0.

4000.	2	2	0.	4000.	-1500.	0.
	1500.					
	2	2	0.	5000.	-1500.	0.
5000.	1500.					
	1					

0	1						
1	CONF	646.	15.2	0.	0.	0.	-4.5
2	CONF	767.	-18.4	0.	0.	0.	-4.5
3	CONF	886.	-4.	0.	0.	0.	-4.5
4	CONE	1000.	-36.4	0.	0.	0.	-4.5
5	CONF	1120.	-22.	0.	0.	0.	-4.5
6	CONE	1222.	-54.4	0.	0.	0.	-4.5
7	HOUSE	-19000.	340.	0.	0.	0.	-90.
8	HOUSE	-19000.	3400.	0.	0.	0.	-90.
9	HOUSE	-19000.	7000.	0.	0.	0.	-90.
10	JAVALIN	-18500.	80.	0.	0.	0.	90.
11	JAVALIN	-18500.	6800.	0.	0.	0.	-90.
12	TERRAIN	-5000.	0.	0.	0.	0.	0.
13	TERRAIN	-5000.	3000.	0.	0.	0.	0.
14	TERRAIN	-5000.	6000.	0.	0.	0.	0.
15	TERRAIN	-15000.	0.	0.	0.	0.	0.
16	TERRAIN	-15000.	3000.	0.	0.	0.	0.
17	TERRAIN	-15000.	6000.	0.	0.	0.	0.
18	LAYOUT	0.	0.	0.	0.	0.	0.

STOP

